





Technical Data of Ceramic Resonator

MURATA Part No.: CSBLA1M00J58-B0

Applied to M34552M8-XXXFP

TOYAMA MURATA MANUFACTURING CO., LTD.

Product Engineering Service Section III
Planning & Market Promotion Department
Piezoelectric Components Group

Approved by	Checked by	Checked by	Issued by	Issued Date	Data No.
 K.Maruno	 R.Miyamae	 K.Tagata	 S.Sakaguchi	Jan 5, 2004	TCD-03-1613

Contents

1.	Test Circuit	1
2.	Temperature Characteristics of Oscillating Frequency, Oscillating Voltage	2
3.	Rise Time, Oscillating Frequency, Oscillating Voltage vs Vdd Characteristics	3
4.	Oscillating Frequency, Oscillating Voltage vs (C1,C2) Characteristics	4
5.	Oscillating Frequency, Oscillating Voltage, Rise Time, Starting Voltage vs C(C1=C2) Characteristics	5
6.	Oscillating Frequency, Oscillating Voltage, Rise Time, Starting Voltage vs Rd Characteristics	6

Test Circuit

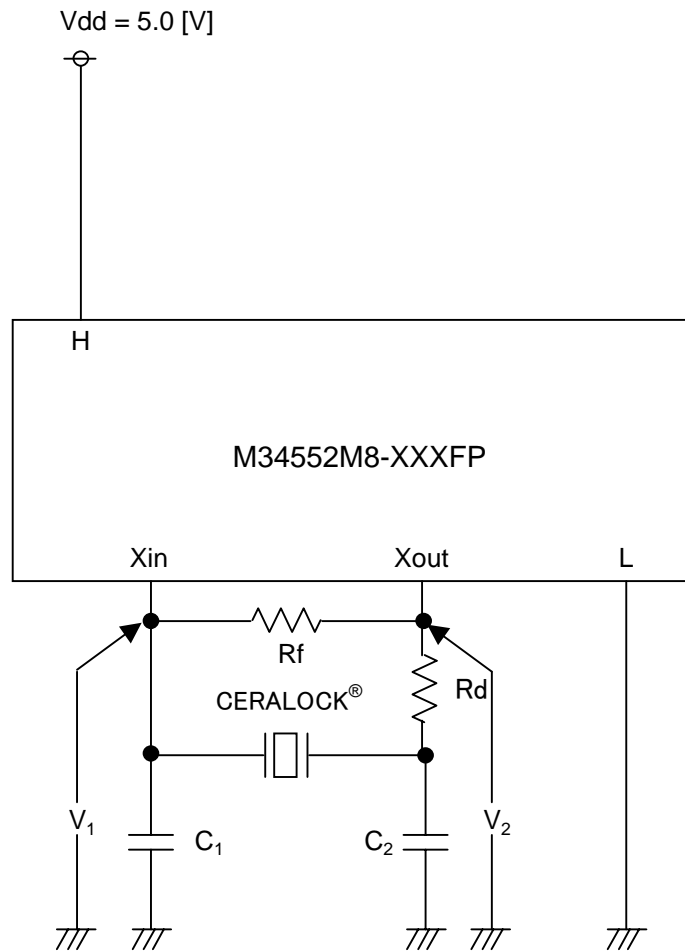

Xin : 20

Xout: 21

H : 18

L : 19,22,25,43

Recommended Value

GERALOCK® : CSBLA1M00J58-B0

Vdd = 1.9 to 5.5 [V]

C1 = 100 [pF]

C2 = 100 [pF]

Rf = 1 [Mohm]

Rd = 2.2 [kohm]

Ta = -20 to 85 [°C]

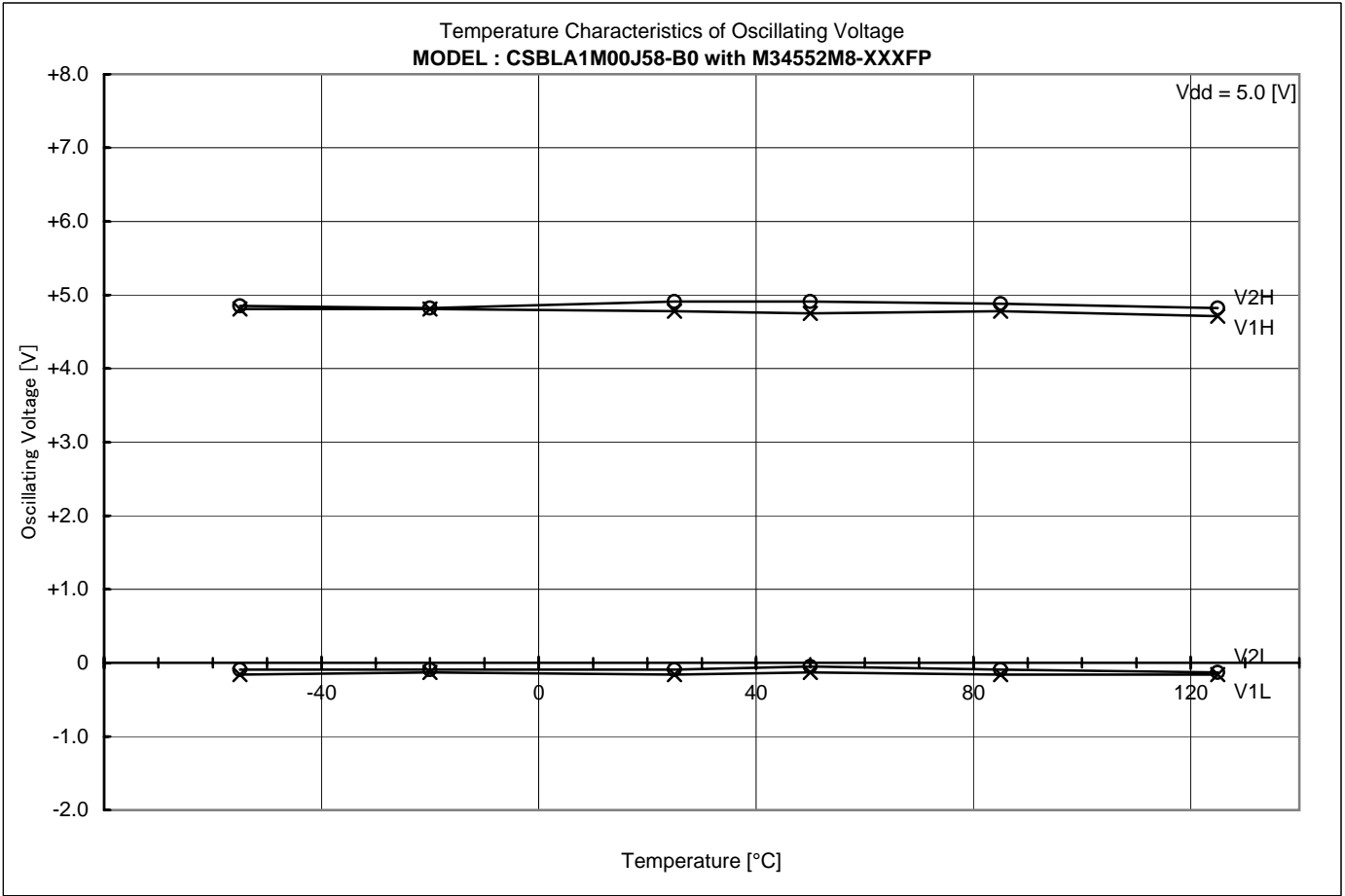
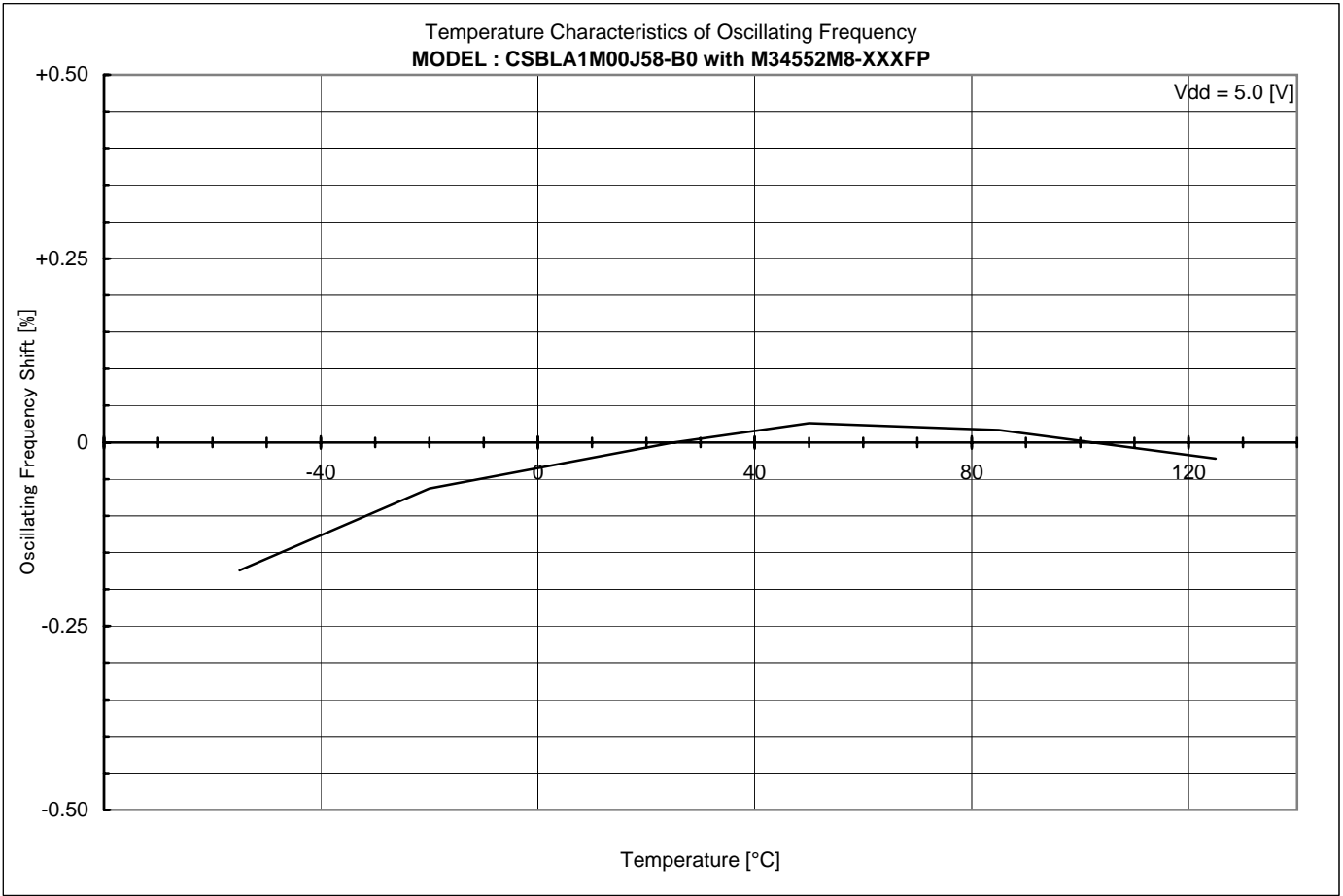

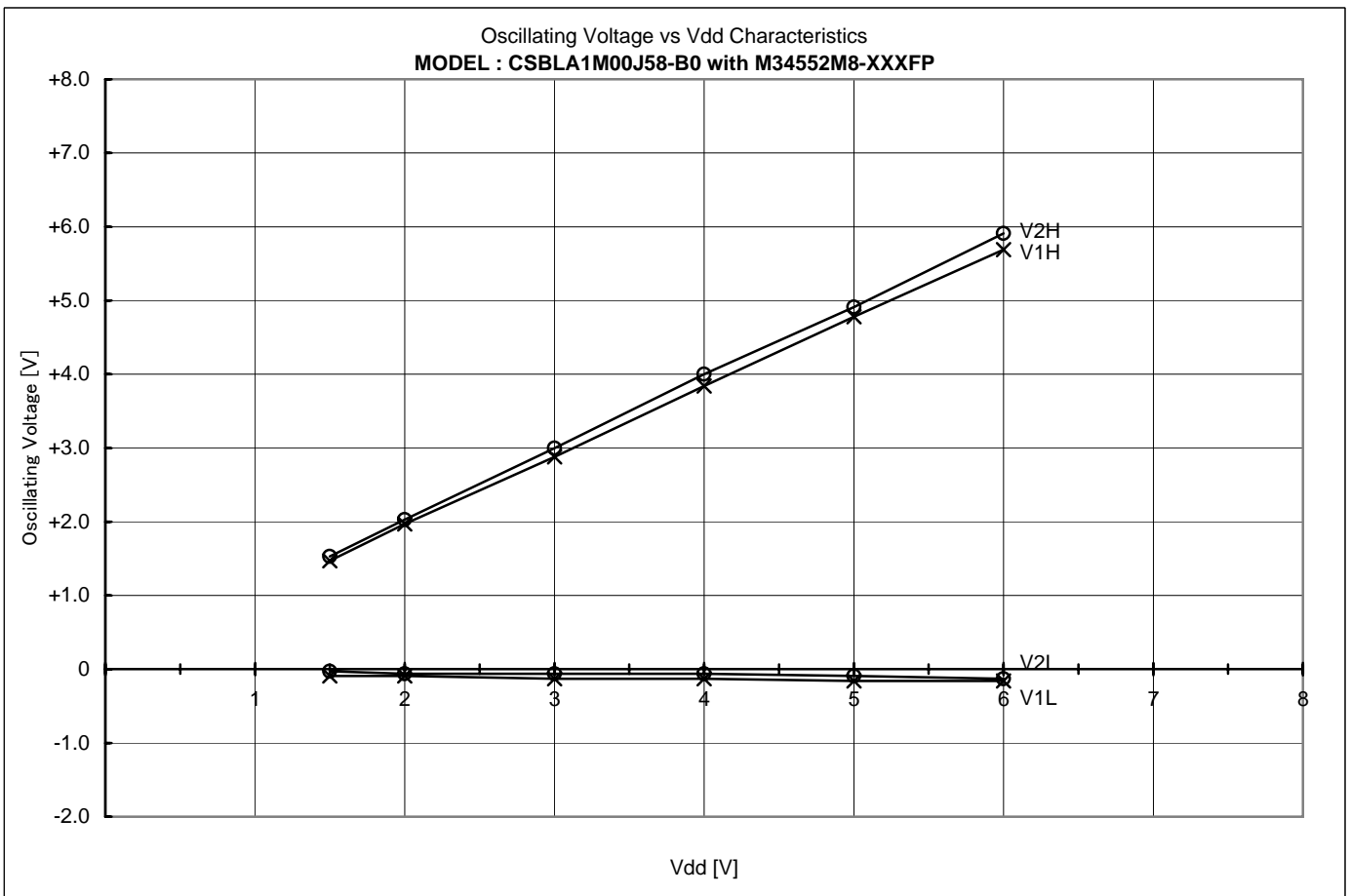
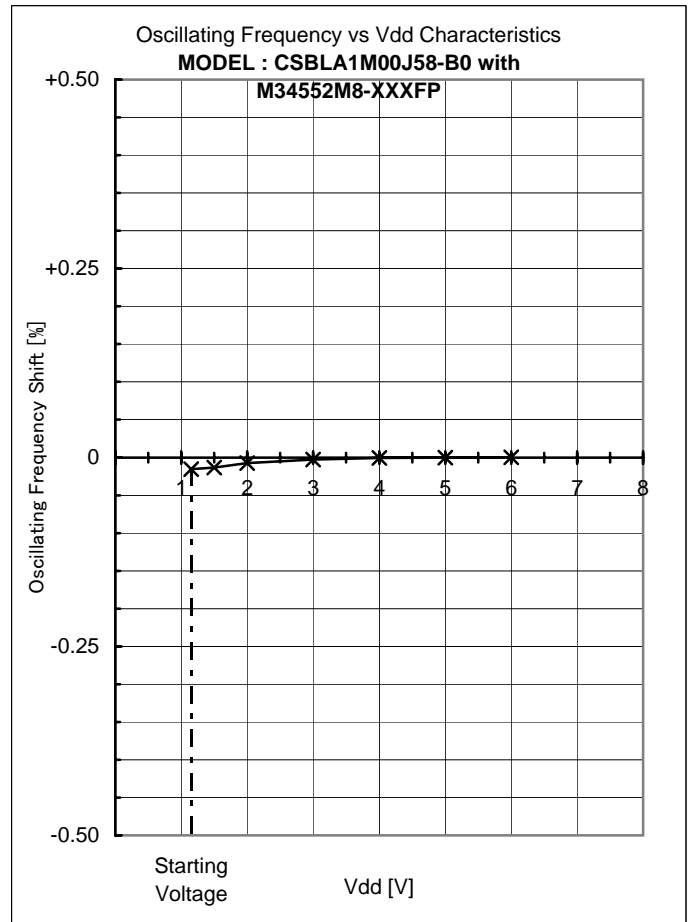
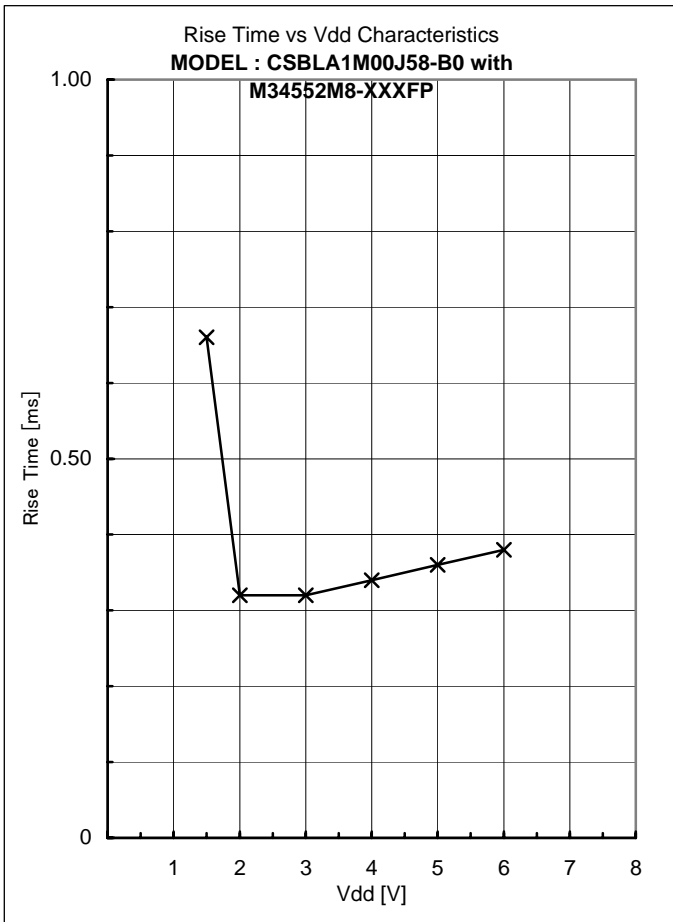

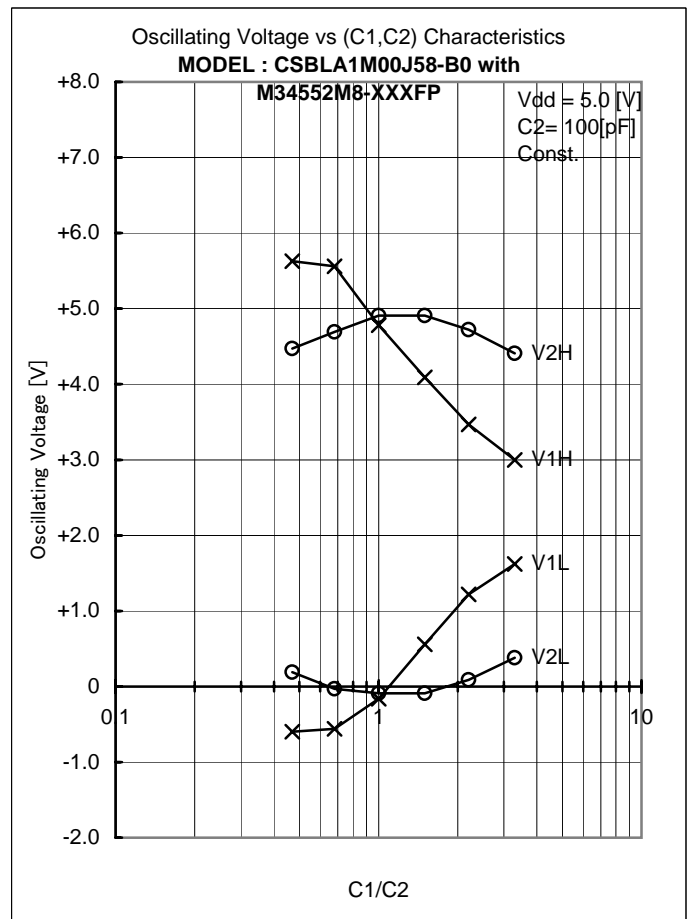
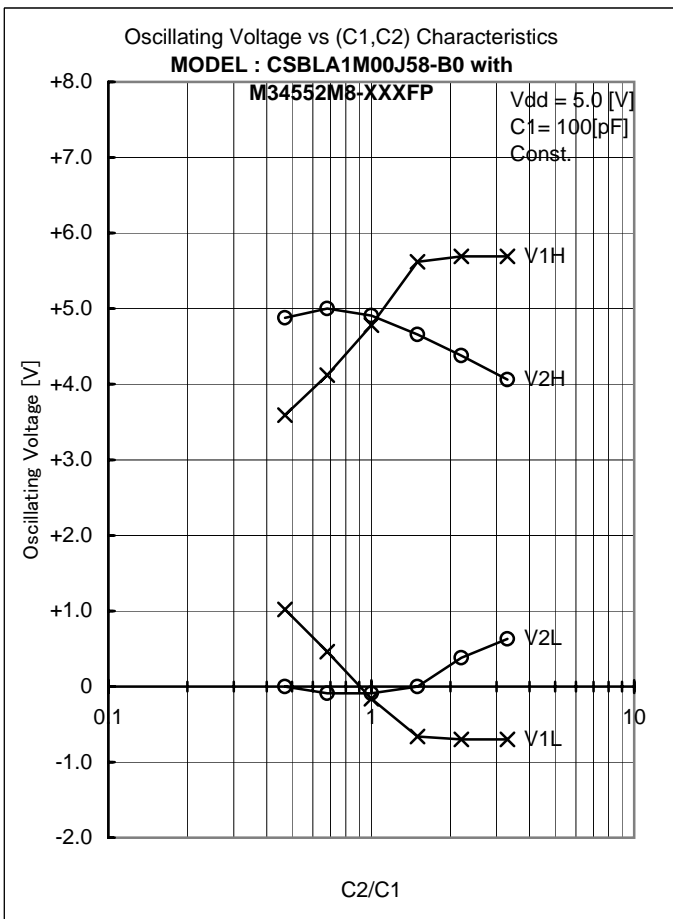
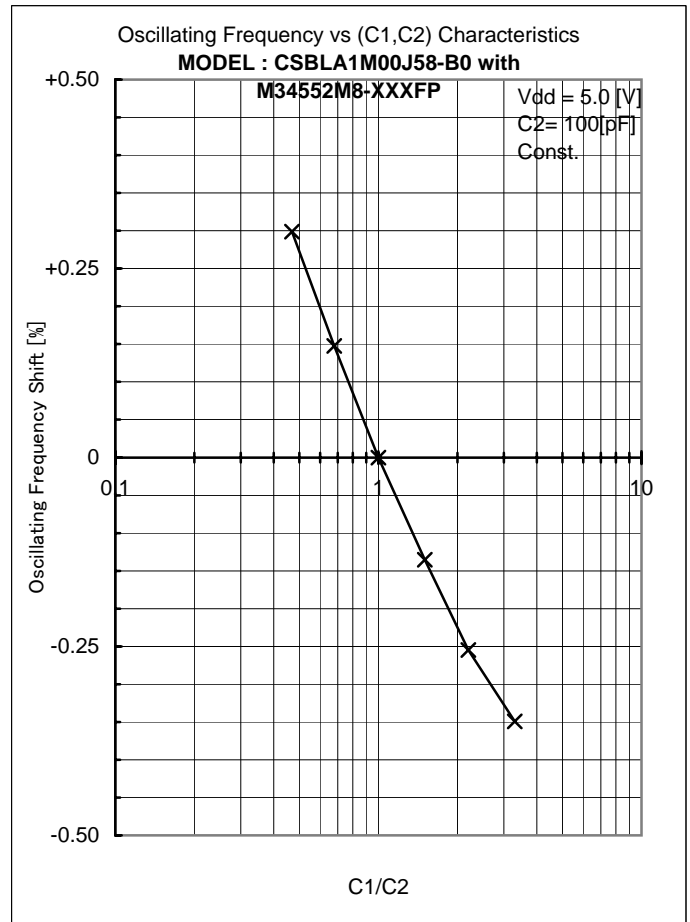
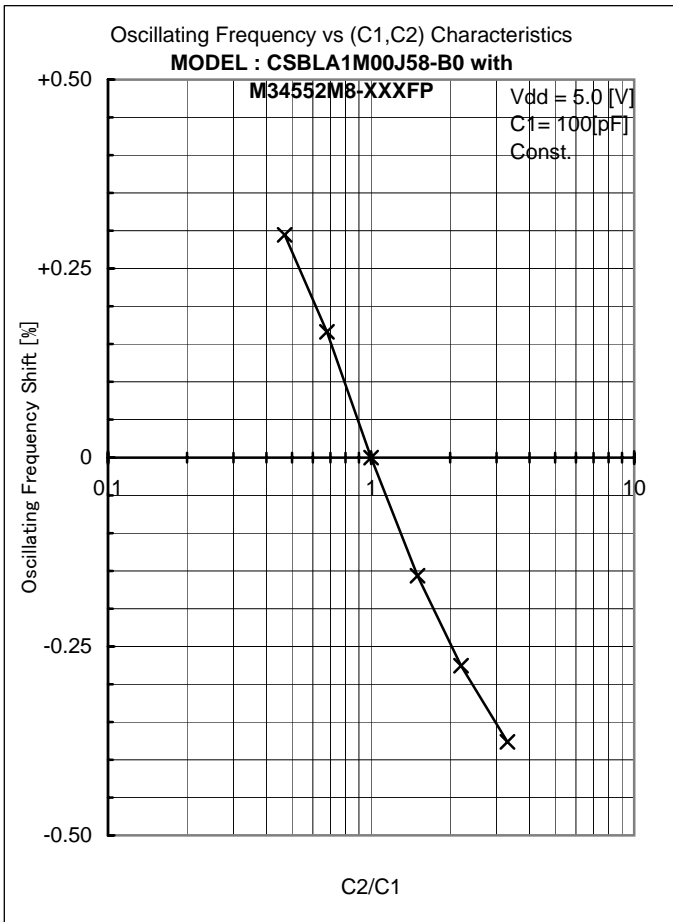

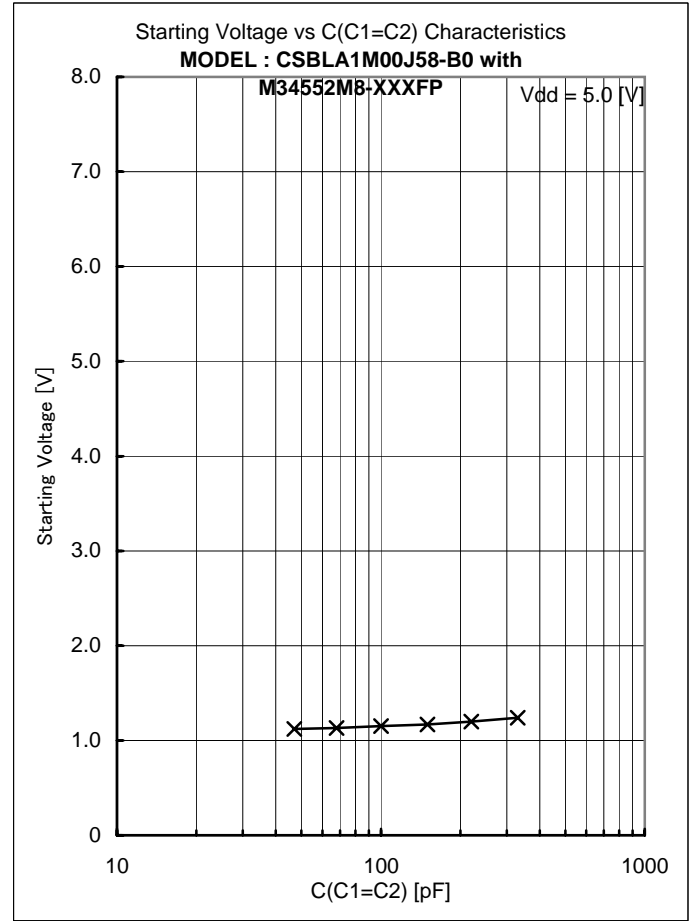
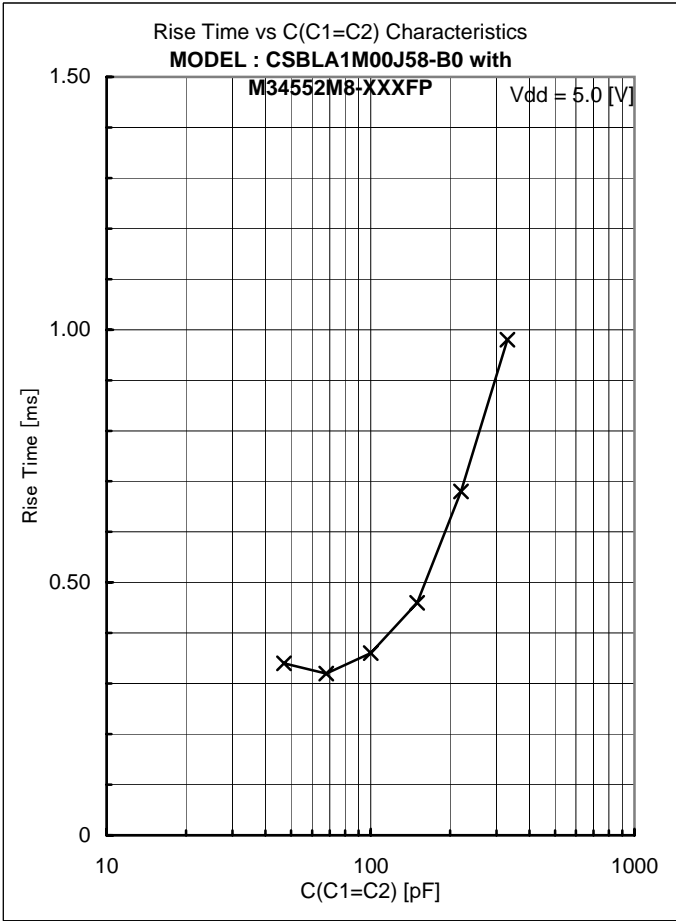
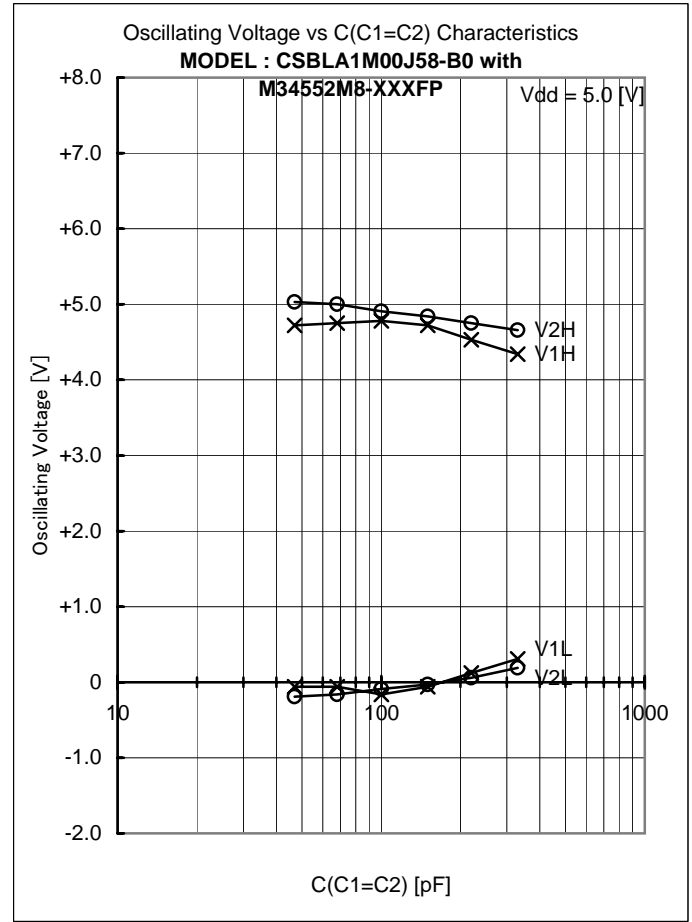
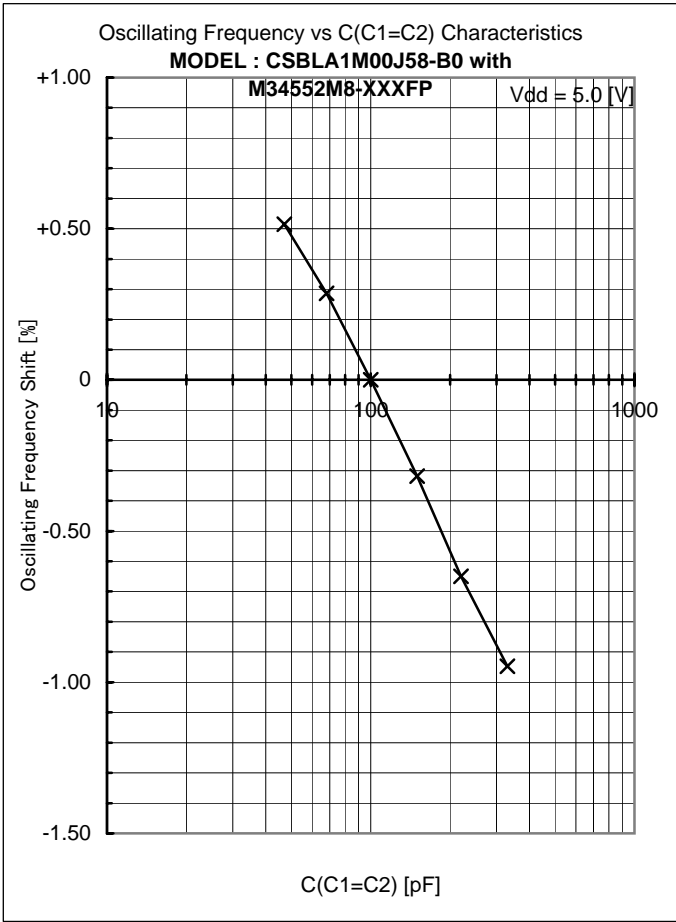

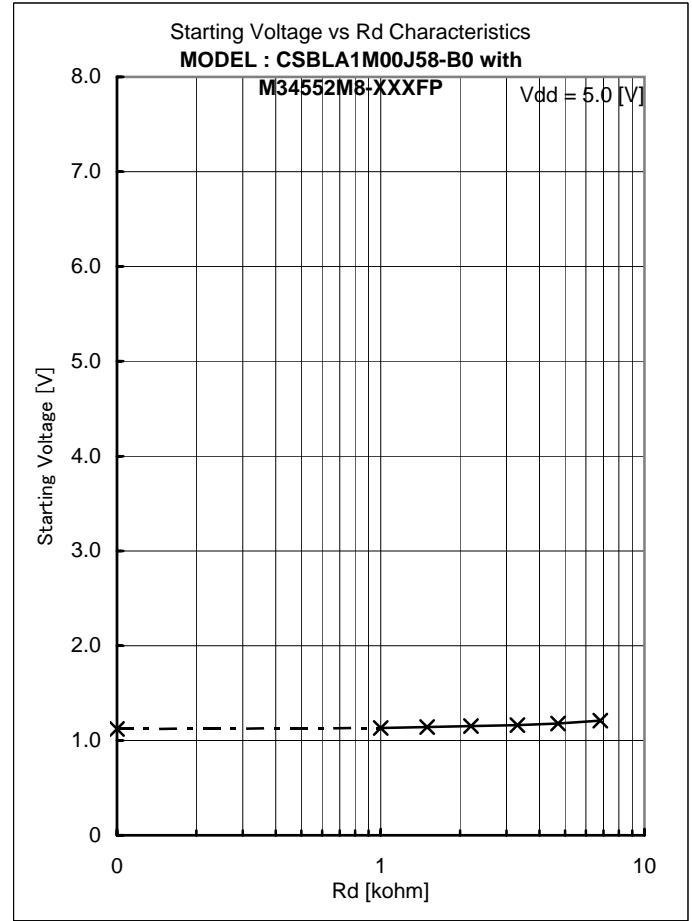
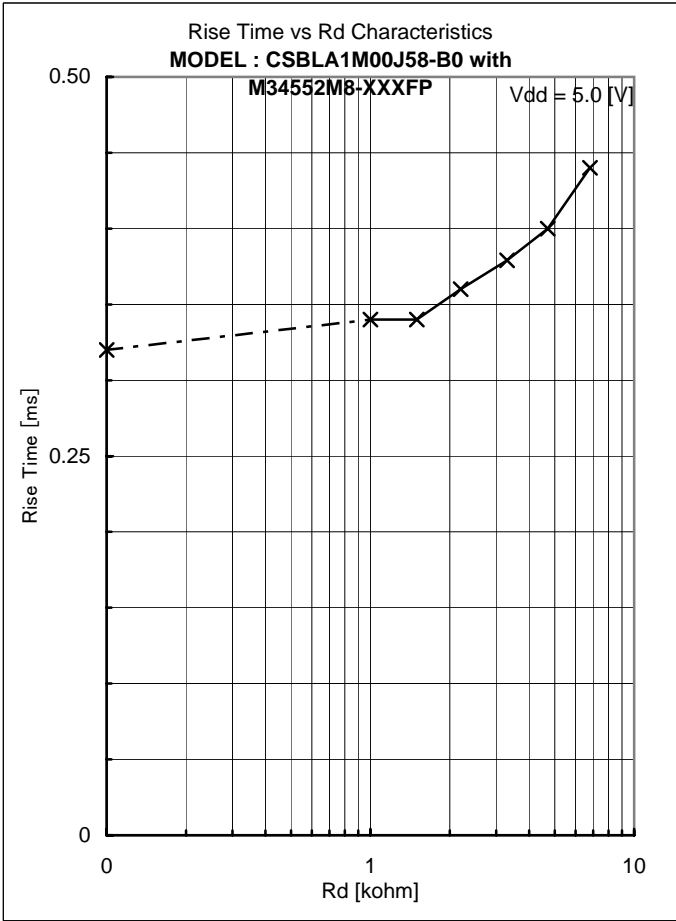
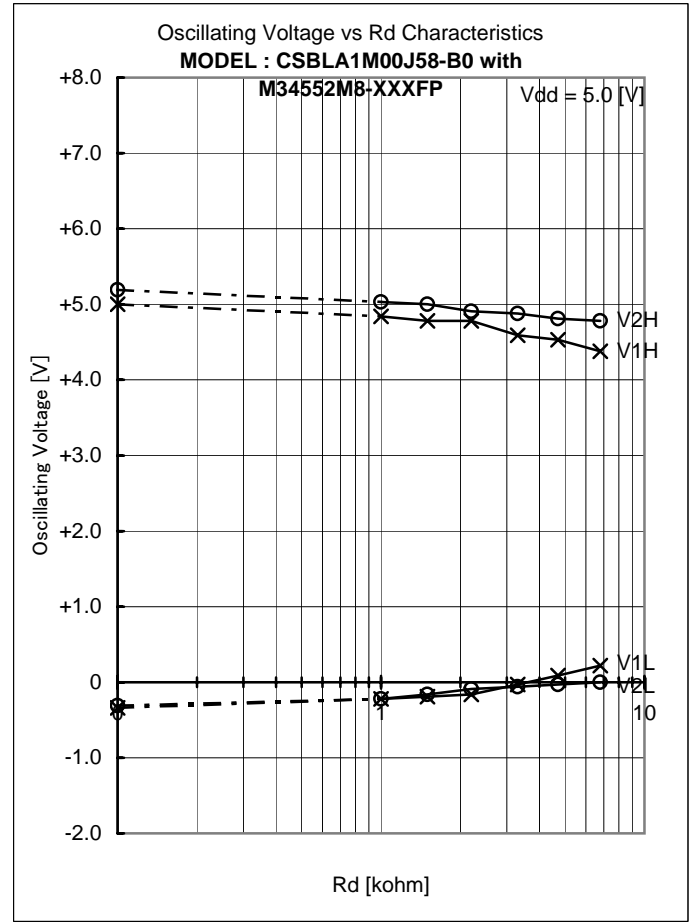
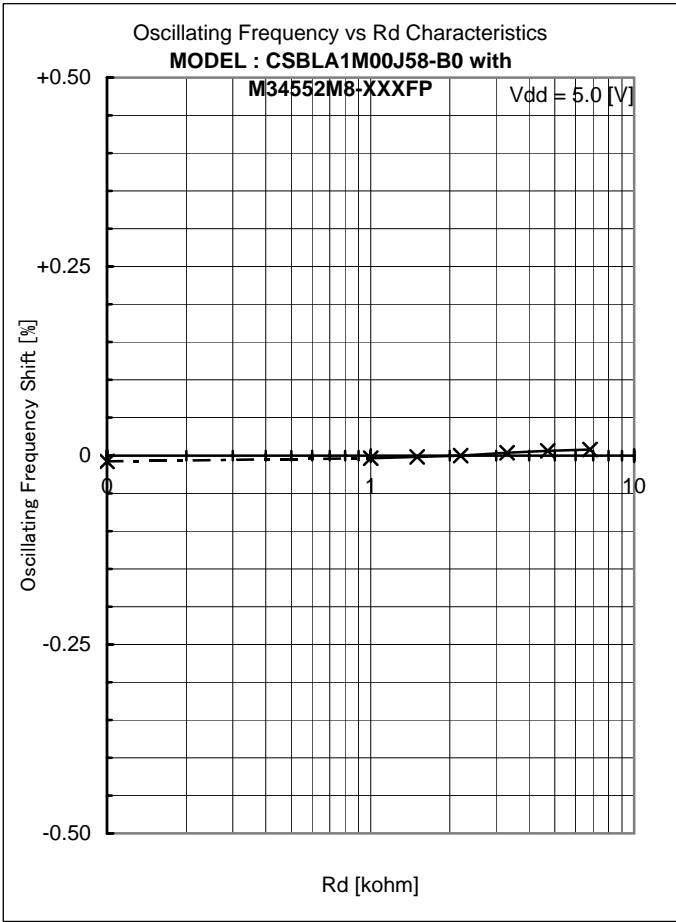

Appendixes

7.	Comparison Table	7
8.	Frequency Correlation Data	8

Comparison Table

IC : No	V1H [V]	V1L [V]	V1p-p [V]	V2H [V]	V2L [V]	V2p-p [V]	Fosc [kHz]	Trise [ms]	Vstart [V]
HH	4.90	-0.32	5.22	4.97	-0.09	5.06	1000.097	0.340	1.38
MM	4.78	-0.16	4.94	4.91	-0.09	5.00	1000.063	0.360	1.15
LL	4.87	-0.20	5.07	4.97	-0.06	5.03	1000.090	0.360	0.87

Ref.

Performance described page 2 to 6 were measured with IC No. MM

Frequency Correlation Data

Sample No.	M34552M8-XXXFP Fosc [kHz]	CD4069UBE Fosc [kHz]	Shift [%]
1	1000.145	999.907	0.0238
2	998.836	998.891	-0.0055
3	1000.369	1000.399	-0.0030
4	999.994	999.724	0.0270
5	1000.163	999.895	0.0268
-			
X	999.901	999.763	0.0138

muRata Standard Circuit

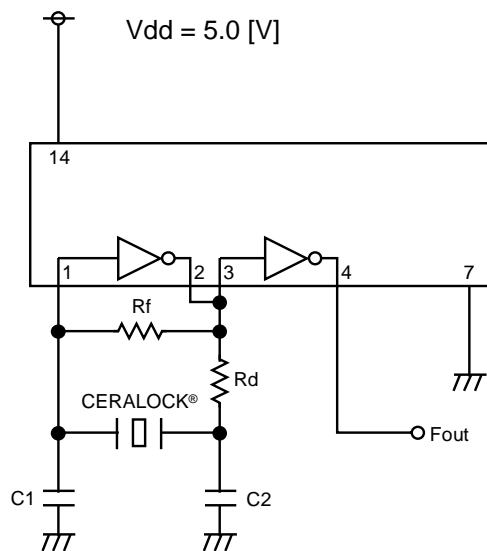

CERALOCK® : CSBLA1M00J58-B0

C1 = 100 [pF]

C2 = 100 [pF]

Rf = 1 [Mohm]

Rd = 5.6 [kohm]