

FEATURES

- Max. propagation delay of 1500ps
- IEE min. of -120mA
- Industry standard 100K ECL levels
- Extended supply voltage option:
VEE = -4.2V to -5.5V
- Voltage and temperature compensation for improved noise immunity
- Internal 75KΩ input pull-down resistors
- 120% faster than Fairchild
- Approximately 40% lower power than Fairchild
- Function and pinout compatible with Fairchild F100K
- Available in 24-pin CERPACK and 28-pin PLCC packages

DESCRIPTION

The SY100S366 is an ultra-fast 9-bit magnitude comparator designed for use in high-performance ECL systems. The device compares the arithmetic value of two 9-bit words and indicates whether one word is greater than or equal to the other. The inputs on the device have 75KΩ pull-down resistors.

PIN CONFIGURATIONS

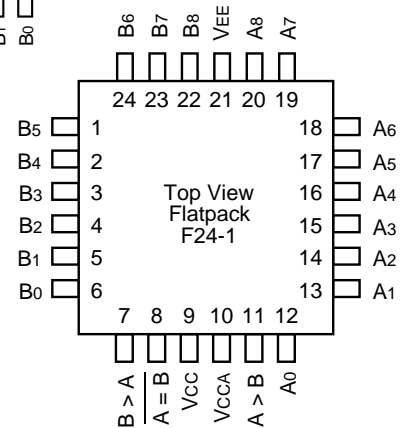
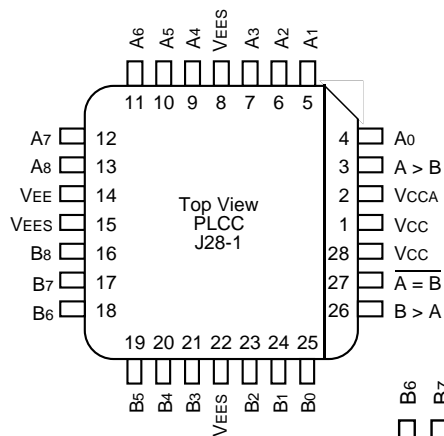

PIN NAMES

Pin	Function
A0 – A8	A Data Inputs
B0 – B8	B Data Inputs
A > B	A Greater Than B Output
B > A	B Greater Than A Output
$\bar{A} = B$	Complement A Equal to B Output (Active LOW)
VEES	VEE Substrate
VCCA	Vcco for ECL Outputs

BLOCK DIAGRAM

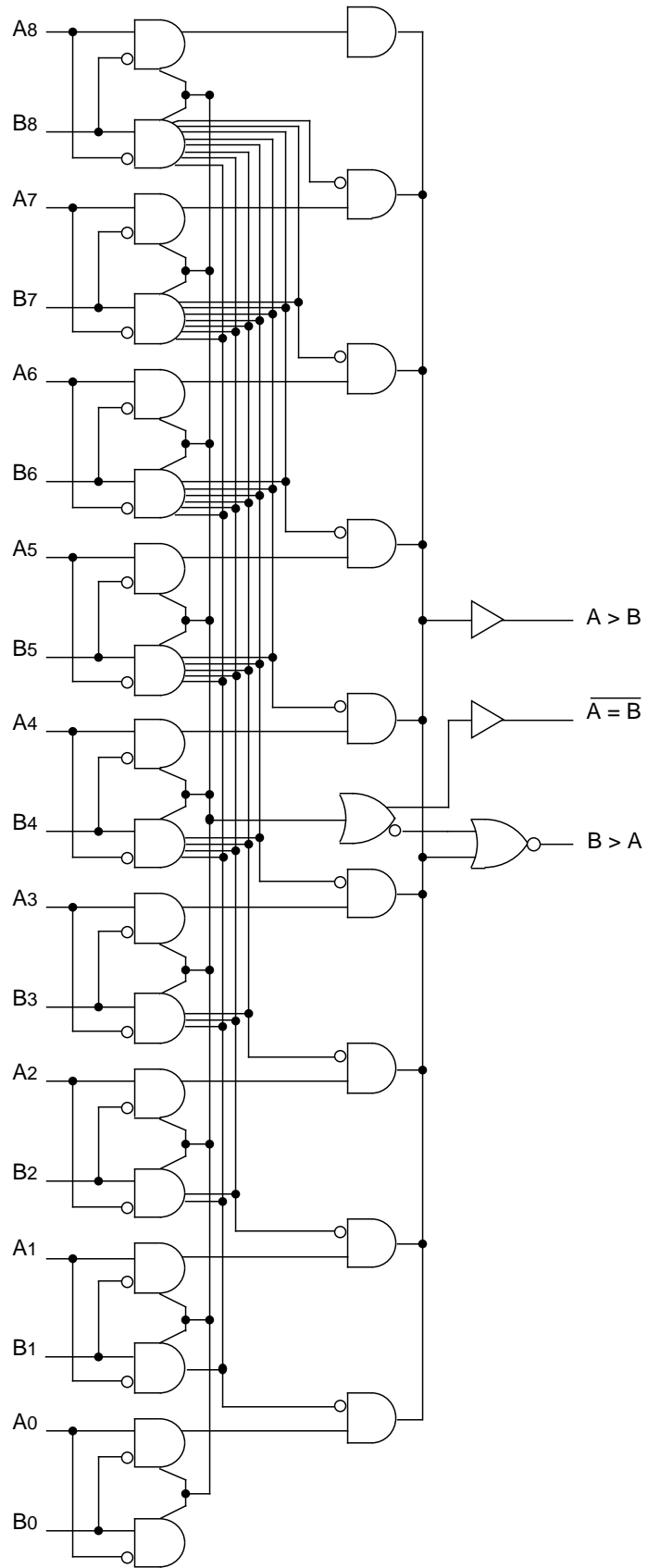

TRUTH TABLE⁽¹⁾

Inputs									Outputs		
A8B8	A7B7	A6B6	A5B5	A4B4	A3B3	A2B2	A1B1	A0B0	A > B	B > A	A = B
H L L H A8 = B8 A8 = B8	H L L H								H L H L	L H L H	H H H H
A8 = B8 A8 = B8 A8 = B8 A8 = B8	A7 = B7 A7 = B7 A7 = B7 A7 = B7	H L L H A6 = B6 A6 = B6	H L L H A5 = B5 A5 = B5						H L H L	L H L H	H H H H
A8 = B8 A8 = B8 A8 = B8 A8 = B8	A7 = B7 A7 = B7 A7 = B7 A7 = B7	A6 = B6 A6 = B6 A6 = B6 A6 = B6	A5 = B5 A5 = B5 A5 = B5 A5 = B5	H L L H A4 = B4 A4 = B4					H L H L	L H L H	H H H H
A8 = B8 A8 = B8 A8 = B8 A8 = B8	A7 = B7 A7 = B7 A7 = B7 A7 = B7	A6 = B6 A6 = B6 A6 = B6 A6 = B6	A5 = B5 A5 = B5 A5 = B5 A5 = B5	A4 = B4 A4 = B4 A4 = B4 A4 = B4	A3 = B3 A3 = B3 A3 = B3 A3 = B3	H L L H A2 = B2 A2 = B2			H L H L	L H L H	H H H H
A8 = B8 A8 = B8 A8 = B8 A8 = B8	A7 = B7 A7 = B7 A7 = B7 A7 = B7	A6 = B6 A6 = B6 A6 = B6 A6 = B6	A5 = B5 A5 = B5 A5 = B5 A5 = B5	A4 = B4 A4 = B4 A4 = B4 A4 = B4	A3 = B3 A3 = B3 A3 = B3 A3 = B3	A2 = B2 A2 = B2 A2 = B2 A2 = B2	A1 = B1 A1 = B1 A1 = B1 A1 = B1	H L L H A0 = B0 A0 = B0	H L L L	L H H H	H H H H

NOTE:

1. H = HIGH Voltage Level, L = LOW Voltage Level, Blank = X = Don't Care

DC ELECTRICAL CHARACTERISTICS

V_{EE} = -4.2V to -5.5V unless otherwise specified; V_{CC} = V_{CCA} = GND

Symbol	Parameter	Min.	Typ.	Max.	Unit	Condition
I _{IH}	Input HIGH Current, All Inputs	—	—	200	μA	V _{IN} = V _{IH} (Max.)
I _{EE}	Power Supply Current	-120	-86	-60	mA	Inputs Open

AC ELECTRICAL CHARACTERISTICS

CERPACK

V_{EE} = -4.2V to -5.5V unless otherwise specified; V_{CC} = V_{CCA} = GND

Symbol	Parameter	T _A = 0°C		T _A = +25°C		T _A = +85°C		Unit	Condition
		Min.	Max.	Min.	Max.	Min.	Max.		
t _{PLH} t _{PHL}	Propagation Delay Data to Output	400	1600	400	1600	400	1600	ps	
t _{TLH} t _{THL}	Transition Time 20% to 80%, 80% to 20%	300	900	300	900	300	900	ps	

AC ELECTRICAL CHARACTERISTICS

PLCC

VEE = -4.2V to -5.5V unless otherwise specified; VCC = VCCA = GND

Symbol	Parameter	TA = 0°C		TA = +25°C		TA = +85°C		Unit	Condition
		Min.	Max.	Min.	Max.	Min.	Max.		
tPLH tPHL	Propagation Delay Data to Output	400	1500	400	1500	400	1500	ps	
tTLH tTHL	Transition Time 20% to 80%, 80% to 20%	300	900	300	900	300	900	ps	

TIMING DIAGRAM

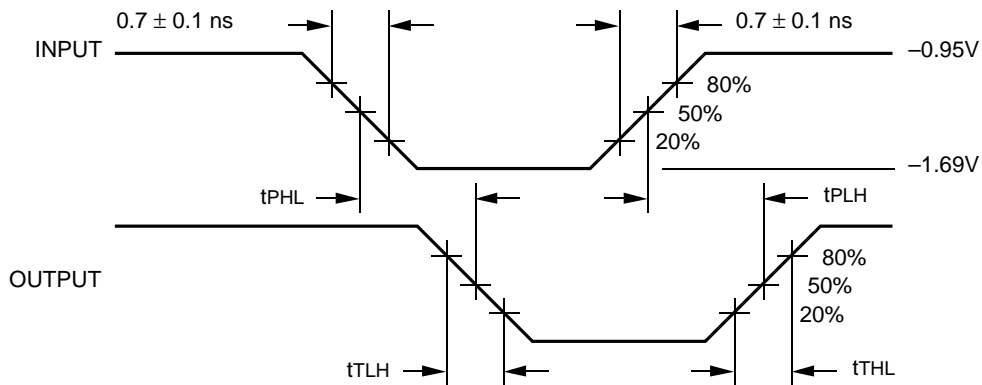

Propagation Delay and Transition Times

NOTE:

VEE = -4.2V to -5.5V unless otherwise specified; VCC = VCCA = GND

PRODUCT ORDERING CODE

Ordering Code	Package Type	Operating Range
SY100S366FC	F24-1	Commercial
SY100S366JC	J28-1	Commercial
SY100S366JCTR	J28-1	Commercial

24 LEAD CERPACK (F24-1)

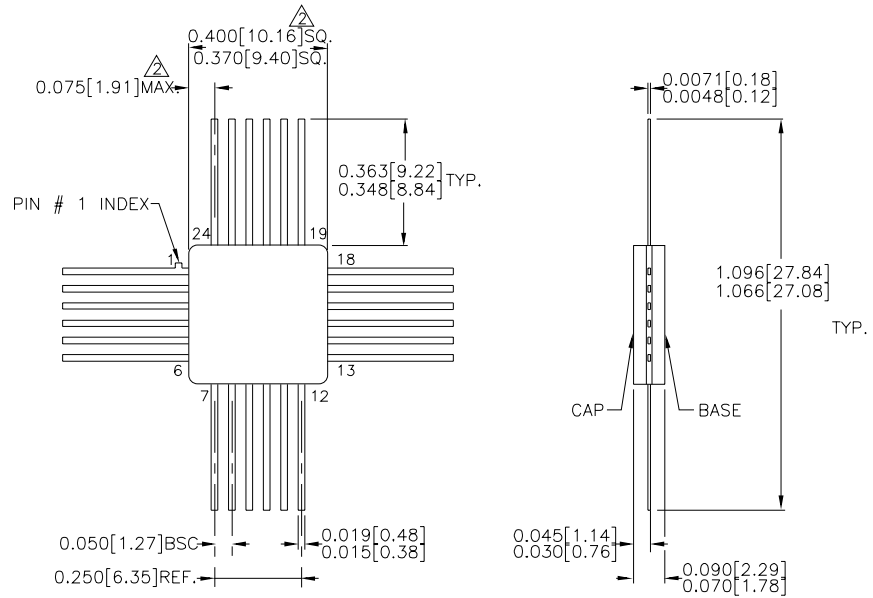

- NOTES:**
1. DIMENSIONS ARE IN INCHES[MM].
 2. THIS DIMENSION INCLUDES GLASS PROTRUSION AND CAP TO BASE ALIGNMENT TOLERANCES.
 3. DIMENSIONS SHOWN ARE MAX/MIN, WHERE NOTED.

Rev. 03

28 LEAD PLCC (J28-1)

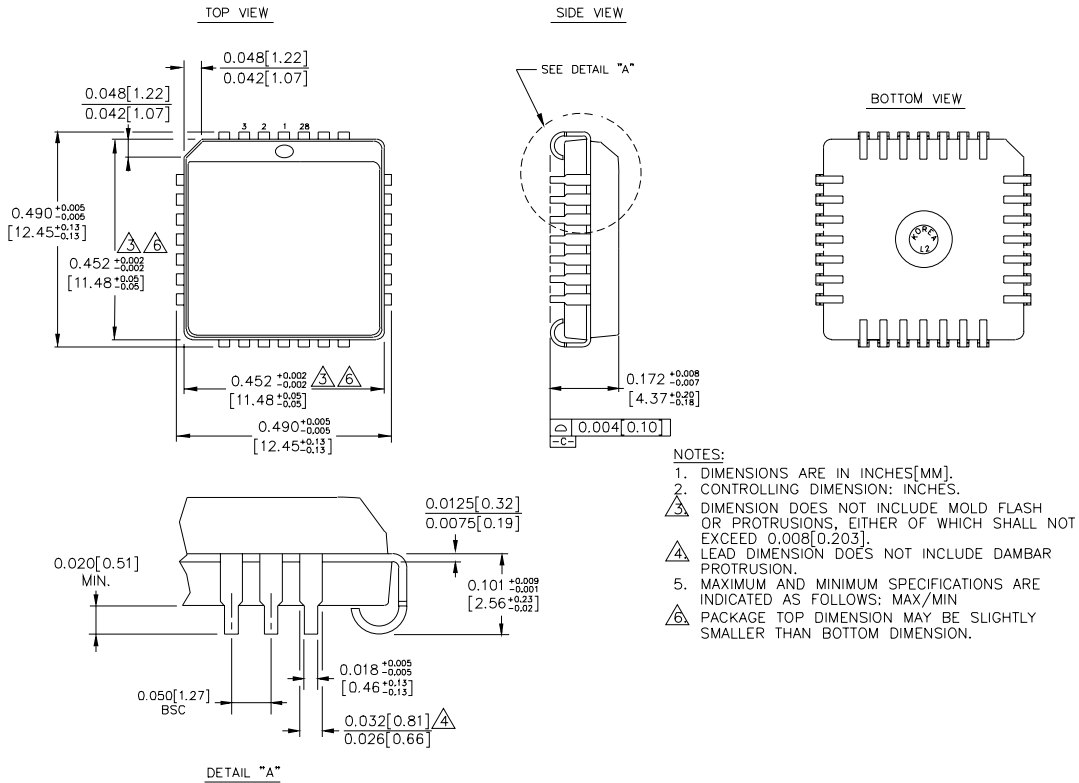

Rev. 03

MICREL-SYNERGY 3250 SCOTT BOULEVARD SANTA CLARA CA 95054 USA

TEL + 1 (408) 980-9191 FAX + 1 (408) 914-7878 WEB <http://www.micrel.com>

This information is believed to be accurate and reliable, however no responsibility is assumed by Micrel for its use nor for any infringement of patents or other rights of third parties resulting from its use. No license is granted by implication or otherwise under any patent or patent right of Micrel Inc.

© 2000 Micrel Incorporated