

NE542

Dual Low-Noise Preamplifier

Product Specification

DESCRIPTION

The NE542 is a dual preamplifier for the amplification of low level signals in applications requiring optimum noise performance. Each of the two amplifiers is completely independent, with individual internal power supply decoupler-regulator, providing 110dB supply rejection and 70dB channel separation. Other outstanding features include high gain (104dB), large output voltage swing ($V_{CC}-2V_{P-P}$), and internal compensation to 10dB. The NE542 operates from a single supply across a range of 9 to 24V.

The NE542 is ideal for use in stereo phono, tape, or microphone preamps and other applications requiring low noise amplification of small signals.

FEATURES

- Low noise — $0.7\mu V$ total input noise
- High gain — 104dB open-loop
- Single supply operation
- Wide supply range 9 to 24V
- Power supply rejection 110dB
- Large output voltage swing ($V_{CC}-2V_{P-P}$)
- Wide bandwidth 15MHz unity gain
- Power bandwidth 100kHz ($15V_{P-P}$)
- Internally-compensated (stable at 10dB)
- Short-circuit protected
- High slew rate $5V/\mu s$

PIN CONFIGURATION

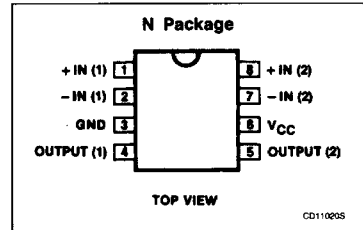

APPLICATIONS

- Tape preamplifier
- Phono preamplifier
- Microphone preamplifier

ORDERING INFORMATION

DESCRIPTION	TEMPERATURE RANGE	ORDER CODE
8-Pin Plastic DIP	0 to +70°C	NE542N

EQUIVALENT CIRCUIT

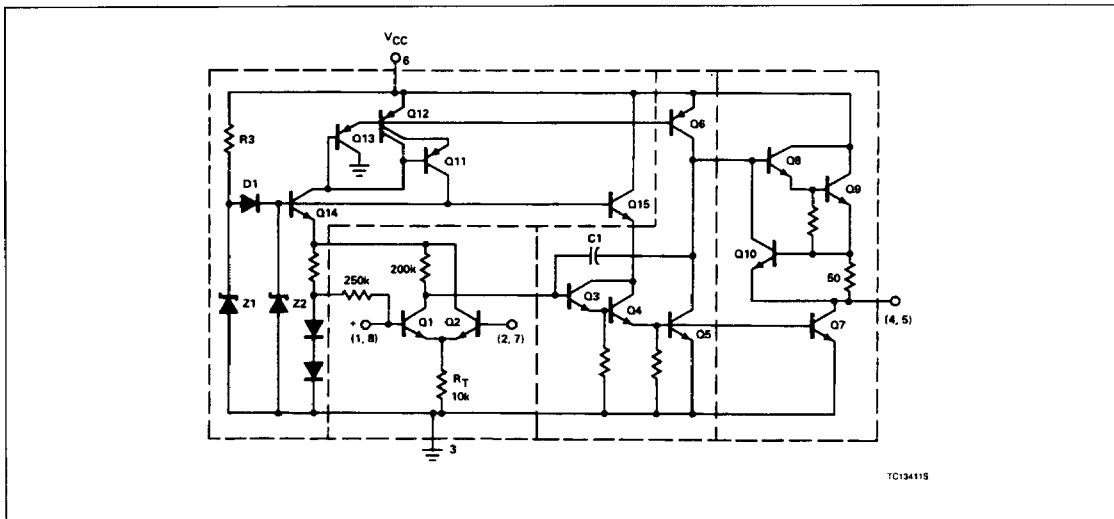

Dual Low-Noise Preamplifier

NE542

ABSOLUTE MAXIMUM RATINGS

SYMBOL	PARAMETER	RATING	UNIT
V _{CC}	Supply voltage	+24	V
P _D	Power dissipation	500	mW
T _A	Operating ambient temperature range	0 to +70	°C
T _{STG}	Storage temperature range	-65 to +150	°C
T _{SOLD}	Lead soldering temperature (10sec max)	+300	= dc

DC ELECTRICAL CHARACTERISTICS T_A = 25°C; V_{CC} = 14V, unless otherwise specified.

SYMBOL	PARAMETER	TEST CONDITIONS	LIMITS			UNIT
			Min	Typ	Max	
V _{CC}	Supply voltage		9		24	V
I _{CC}	Supply current	V _{CC} = 9 to 18V, R _L = ∞		9	15	mA
R _{IN}	Input resistance Positive input Negative input			100 200		kΩ kΩ
R _{OUT}	Output resistance	Open-loop		150		Ω

AC ELECTRICAL CHARACTERISTICS T_A = 25°C; V_{CC} = 14V, unless otherwise specified.

SYMBOL	PARAMETER	TEST CONDITIONS	LIMITS			UNIT
			Min	Typ	Max	
A _V	Voltage gain	Open-loop		160,000		V/V
I _{IN}	Negative Input current				0.5	
I _{OUT}	Output current	Source Sink (linear operation)	8 2	14 3		mA mA
V _{OUT}	Output voltage swing		V _{CC} - 2.5	V _{CC} - 2		V
SR	Small signal bandwidth Slew rate			15 5		MHz V/μs
P _{BW}	Power bandwidth	15V _{P,P}		100		kHz
V _{IN}	Maximum input voltage	Linear operation, < 2.5% distortion			300	mV _{RMS}
PSRR	Power supply rejection ratio	f = 60, 120Hz f = 1kHz		100 110		dB dB
	Channel separation	f = 1kHz	40	70		dB
THD	Total harmonic distortion	40dB gain, f = 1kHz		0.1	0.3	%
	Total equivalent input noise	R _S = 600Ω, 100 - 10,000Hz		0.7	1.2	μV _{RMS}
	Noise figure	R _S = 50kΩ, 10 - 10,000Hz R _S = 20kΩ, 10 - 10,000Hz R _S = 10kΩ, 10 - 10,000Hz R _S = 5kΩ, 10 - 10,000Hz		1.2 1.2 1.5 2.4		dB dB dB dB

Dual Low-Noise Preamplifier

NE542

TYPICAL PERFORMANCE CHARACTERISTICS

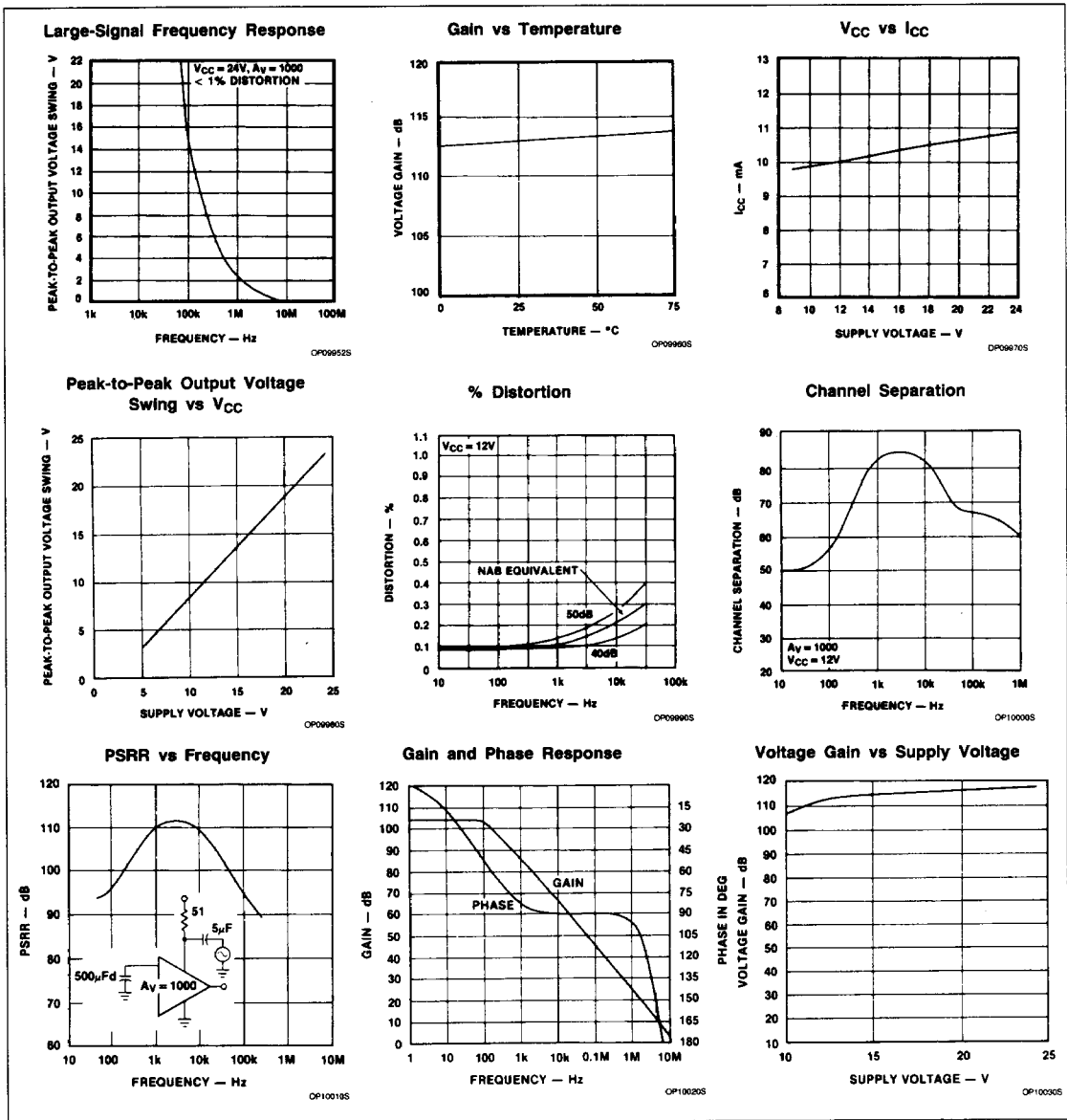

Dual Low-Noise Preamplifier

NE542

TYPICAL PERFORMANCE CHARACTERISTICS (Continued)

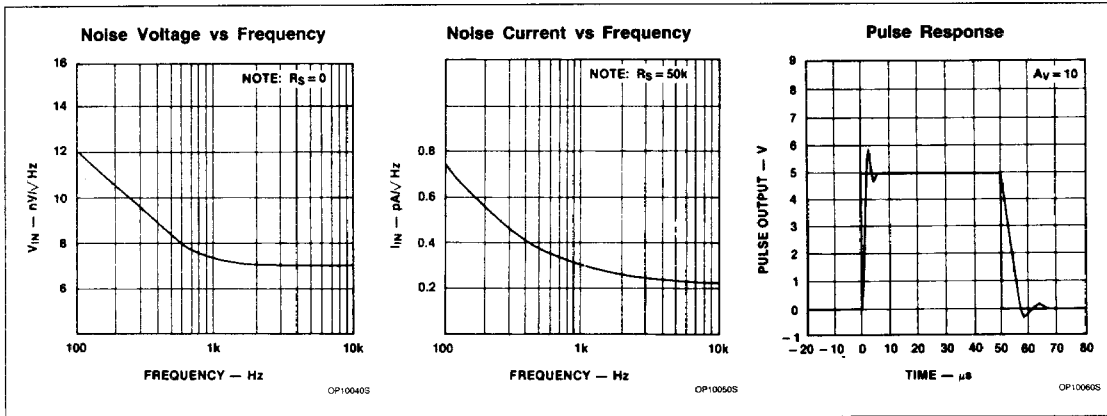

TYPICAL APPLICATIONS

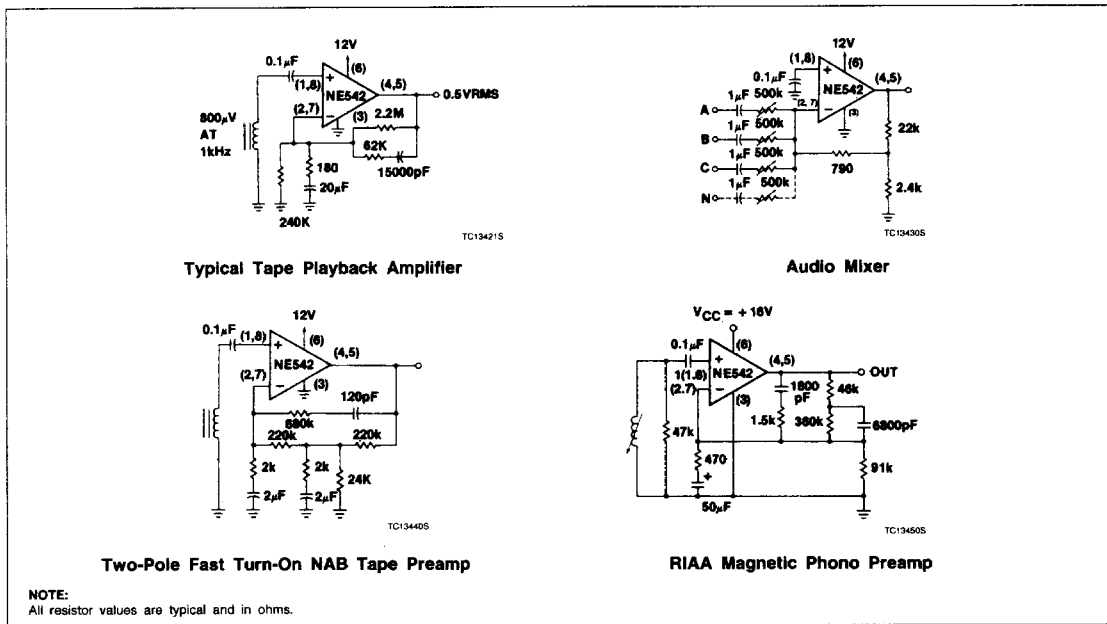

NOTE:
All resistor values are typical and in ohms.