

6-Channel High Efficiency Charge Pump White LED Driver

Features and Benefits

- Proprietary adaptive control scheme (1×, 1.5×, 2×)
- 0.5% typical WLED current matching
- Drives up to 6 white LEDs
 - Main display backlight (up to 6 WLEDs)
 - Main display and sub display backlight
 - Main display and low-current flash/torch
- 30 mA per WLED
- 2× serial dimming interfaces
- 320 mA charge pump capability
- Low EMI design and soft start function
- Short circuit, overvoltage, thermal shutdown protection
- 0.75 mm nominal height (very thin profile), 3 × 3 mm footprint packages

Package: 16 pin QFN/MLP (suffix ES)

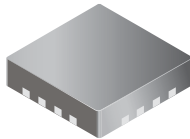

Approximate scale 1:1



Description

The A8434 high efficiency charge pump ICs offer a simple, low-cost WLED (white LED) driver solution for driving up to six WLEDs in various application configurations, either all six backlighting a single display, or for multiple displays, such as four WLEDs as the main display backlight, with the other two WLEDs used for backlighting a sub display or a low-current flash/torch. Using a proprietary control scheme (1×, 1.5×, and 2×), the A8434 can deliver well-matched WLED current while maintaining the highest efficiency and low EMI.

The WLED current is regulated over the entire range of Li+ battery voltage to provide uniform intensity. WLED brightness and on/off can be controlled for the main display and sub display/torch through 2 single-wire serial interface pins.

The A8434 is available in an QFN/MLP-16 space-conserving (3 × 3 mm footprint) ES package.

Applications include:

- White LED backlights for cellular phones, PDAs
- Digital cameras, camcorders
- Portable audio devices and MP3s
- Other portable device white LED backlighting

Typical Applications

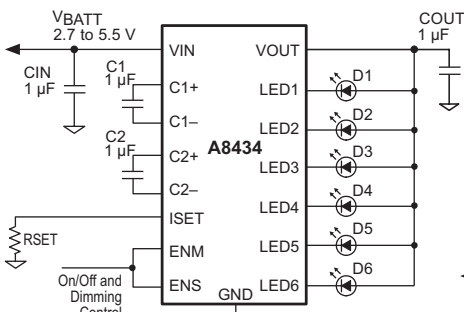

Figure 1. 6 × 30 mA WLED display

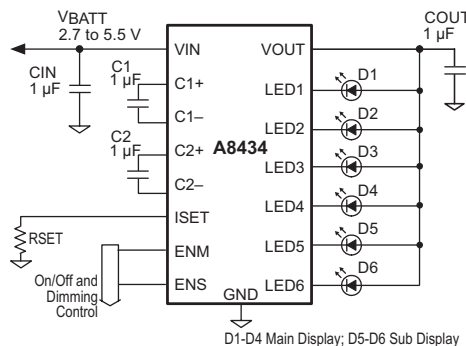

Figure 2. 4 × 30 mA main with 2 × 30 mA sub display

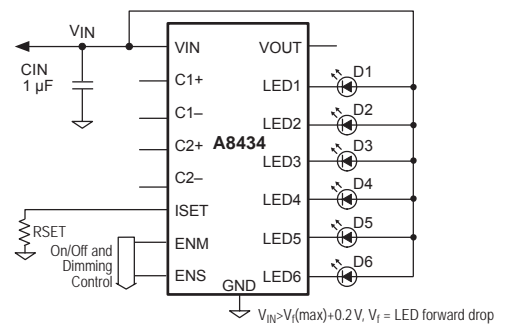
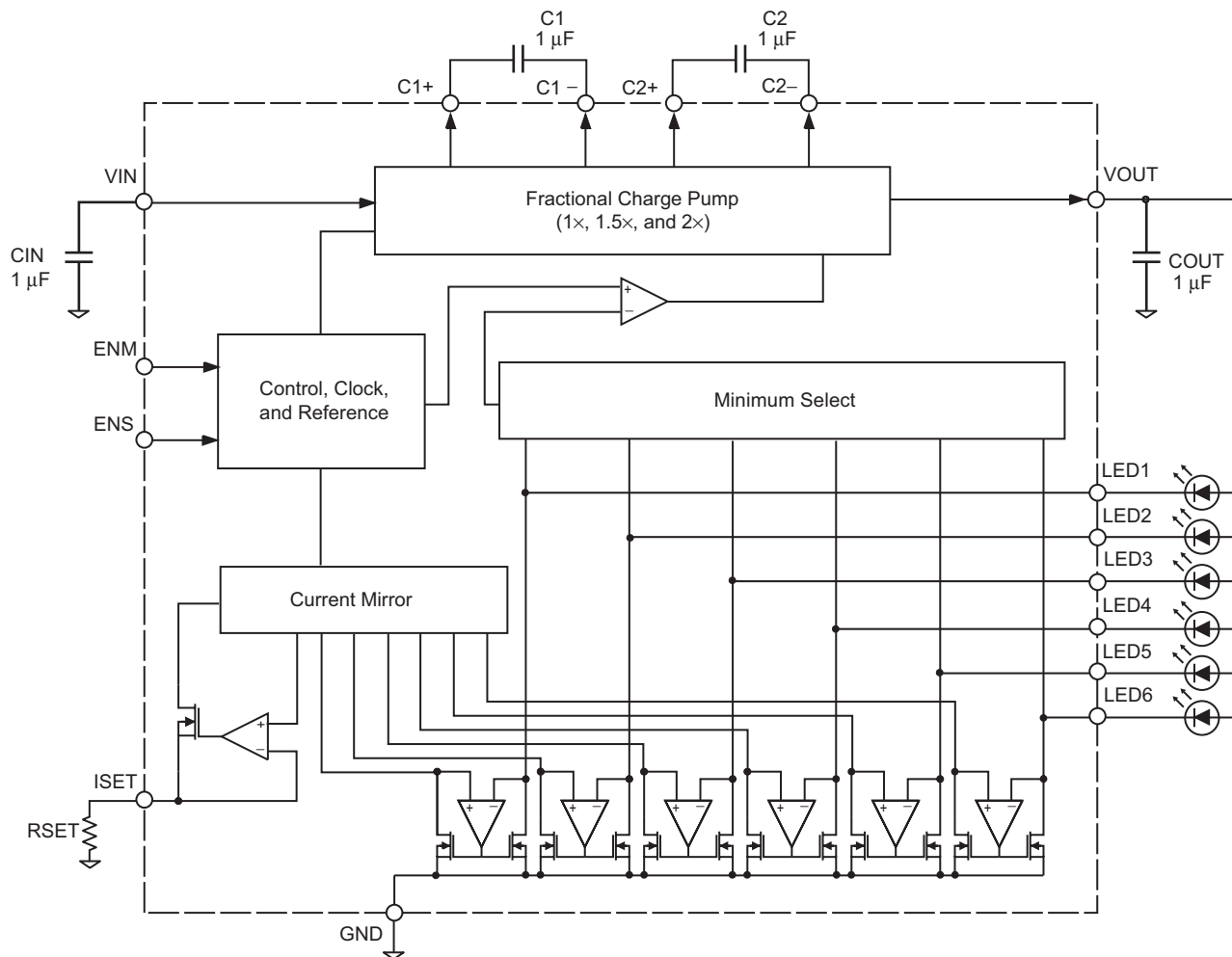

Figure 3. High efficiency current sink

Functional Block Diagram



Absolute Maximum Ratings

Input or Output Voltage	
VIN, VOUT, C1+, C1-, C2+, C2- to GND	-0.3 to 6 V
All other pins	-0.3 to VIN + 0.3 V
VOUT Short Circuit to GND	Continuous
Operating Ambient Temperature, TA	-40°C to 85°C
Junction Temperature, TJ(max)	150°C
Storage Temperature, TS	-55°C to 150°C

Package Thermal Characteristics

ES Package $R_{\theta JA} = 68 \text{ }^\circ\text{C/W}$
(vendor data, on 4-layer PCB; unverified)
Additional information is available on the Allegro website.

The device package is lead (Pb) free, with 100% matte tin leadframe plating.

Use the following complete part number when ordering:

Part Number	Packaging*	Package Type
A8434EESTR-T	7-in. reel, 1500 pieces/reel	ES, 3 × 3 mm MLP-16

*Contact Allegro for additional packing options.



Pin-out Diagram

ES Package

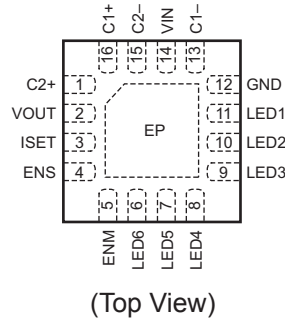

Terminal List Table

Name	Number	Function
C1–	13	Negative terminal of capacitor C1. Connect capacitor C1 between C1+ and C1–.
C1+	16	Positive terminal of capacitor C1.
C2–	15	Negative terminal of capacitor C2
C2+	1	Positive terminal of capacitor C2. Connect capacitor C2 between C2+ and C2–.
ENS	4	Enable and dimming control input for sub display WLED group.
ENM	5	Enable and dimming control input for main display WLED group.
EP	–	Exposed metal pad on bottom side. Connect this to ground plane for better thermal performance.
GND	12	Ground.
ISET	3	Connect RSET resistor to ground to set desired constant current through main and sub WLEDs. $I_{LED(max)} = 220 \times 0.6 V / R_{SET}$
LED1, LED2, LED3, and LED4	8, 9, 10, and 11	Current sink for main display WLEDs. If not used, connect to VOUT, but do not leave open. If left open, the IC works in 2 × mode.
LED5 and LED6	6 and 7	Current sink for sub display WLEDs. If not used, connect to VOUT, but do not leave open. If left open, the IC works in 2 × mode.
VIN	14	Power supply voltage input.
VOUT	2	Charge pump output voltage for display backlight and flash/torch LED anodes. Connect a 1 μF capacitor, COUT, between VOUT and GND (see figure 2).

ELECTRICAL CHARACTERISTICS^a VIN = ENM = ENS = 3.6 V, C1 = C2 = 1 μF, CIN = COUT = 1 μF, RSET = 6.49 kΩ, TA = -40°C to +85°C; typical values are at TA = 25°C; unless otherwise noted

Characteristics	Symbol	Test Conditions	Min.	Typ.	Max.	Units
Input Voltage Range	V _{IN}		2.7	–	5.5	V
Undervoltage Lockout Threshold	V _{UVLO}	V _{IN} falling	2.25	2.45	2.60	V
UVLO Hysteresis Window	V _{UVLOHYS}		–	60	–	mV
Quiescent Current	I _Q	Switching in 1.5× or 2.0× mode; T _A = 25°C	–	6	–	mA
		ENS = ENM = GND; T _A = 25°C	–	0.1	2	μA
Soft-start Completion Time	t _{ss}		–	0.4	–	ms
ISET Bias Voltage	V _{ISETBIAS}		–	0.6	–	V
ISET Leakage in Shutdown	V _{ISETLKG}		–	0.01	1	μA
ISET Current Range	I _{SET}		40	–	140	μA
ISET to LEDx Current Ratio for LED1 through LED6	I _{LEDx} /I _{SET}	100% setting, I _{SET} = 60 μA	–	220	–	A/A
I _{LED} Accuracy for LED1 through LED6 ^b	E _{ILEDERR}	ENS = ENM = VIN	–	±1.6	–	%
LED Current Matching for LED1 through LED4 ^c	ΔI _{LED14}	ENS = GND, ENM = VIN	–	±0.5	–	%
LED Current Matching for LED5 and LED6 ^c	ΔI _{LED56}	ENS = VIN, ENM = GND	–	±0.5	–	%
Regulation Voltage at LEDx (1.5× and 2× modes)	V _{REG}	ENS = ENM = VIN	–	250	–	mV
1× mode to 1.5× or 1.5× to 2× mode transition voltage at LEDx	V _{trans}	V _{LEDx} falling	–	150	–	mV
Transition-Dropout Delta ^d	ΔV _{dr}	Measured as V _{trans} – V _{dropout}	–	40	–	mV
Open Loop Output Resistance ^e	R _{OUT}	1× mode (V _{IN} – V _{OUT})/I _{OUT}	–	1	–	Ω
		1.5× mode (1.5 × V _{IN} – V _{OUT})/I _{OUT}	–	2.5	–	Ω
		2× mode (2 × V _{IN} – V _{OUT})/I _{OUT}	–	5	–	Ω
LED Leakage in Shutdown	V _{LEDLKG}	ENS = ENM = GND, V _{IN} = 5.5 V	–	0.01	1	μA
Oscillator Frequency	f _{osc}		–	1	–	MHz
Output Overvoltage Protection (guaranteed by design)	V _{ovp}	Open circuit at any LED that is programmed to be in the ON state	–	–	6.0	V
ENS and ENM Input High Threshold	V _{IH}	Input high logic threshold	1.4	–	–	V
ENS and ENM Input Low Threshold	V _{IL}	Input low logic threshold	–	–	0.4	V
Input High Current	I _{IH}	V _{IH} = VIN	–	–	1	μA
Input Low Current	I _{IL}	V _{IL} = GND	–	–	1	μA
ENM and ENS Pulse Low Time (figure 5)	t _{LO}		0.5	–	250	μs
ENM and ENS Pulse High Time (figure 5)	t _{HI}		0.5	–	–	μs
ENM and ENS Initial Pulse High Time (figure 5)	t _{INIHI}	First ENM or ENS pulse after shutdown	50	–	–	μs
Shutdown or Dimming Reset Delay	t _{SHDN}	Falling edge of ENS and/or ENM	–	0.5	–	ms
Thermal Shutdown Threshold	T _{TSD}	20°C hysteresis	–	165	–	°C

^aSpecifications for the range T_A = -40°C to 85°C are guaranteed by design.

^bI_{LED} accuracy is defined as (I_{SET} × 220 – I_{LEDAVG})/(I_{SET} × 220).

^cLED current matching is defined as (I_{LEDx} – I_{LEDAVG})/I_{LEDAVG}.

^dDropout voltage V_{dropout} is defined as LEDx-to-GND voltage at which I_{LEDx} drops 10% below the value of I_{LEDx} when V_{LEDx} = 300 mV.

^eThe open loop output resistance, R_{OUT}, for 1.5× mode is measured when one of the LEDx pins is tied to ground or open (thus its voltage is always less than 80 mV).

Performance Characteristics

Tests performed using application circuit shown in figure 2
 $T_A = 25^\circ\text{C}$, $V_{IN} = 3.6\text{ V}$ (unless otherwise noted)

Efficiency versus Supply Voltage
 V_{IN} falling, $V_f = 3.4\text{ V}$ at 20 mA

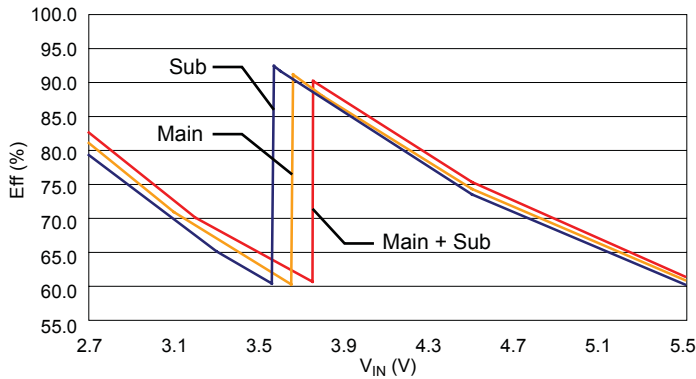

Efficiency versus Supply Voltage
 V_{IN} falling, $V_f = 3.1\text{ V}$ at 10 mA

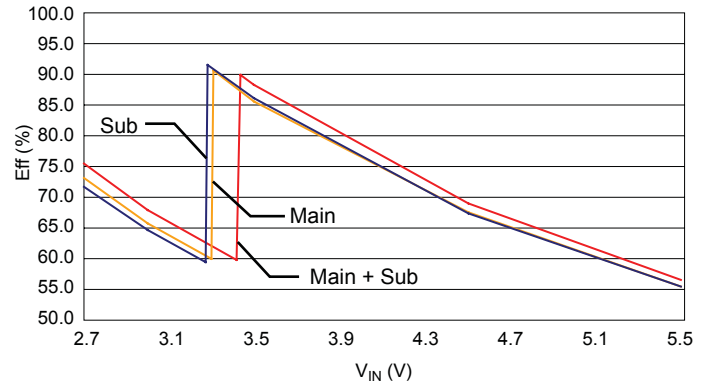

Logic Level

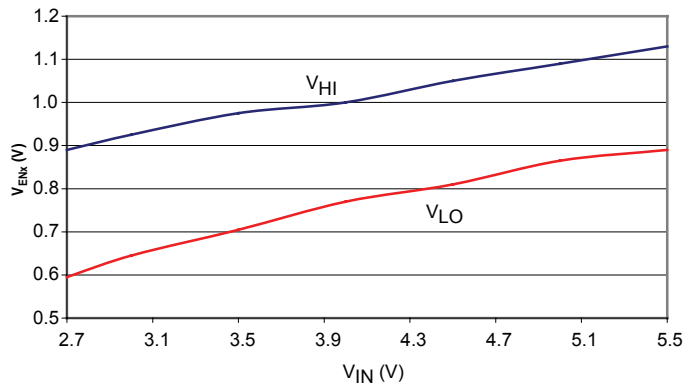

R_{SET} versus LED Current

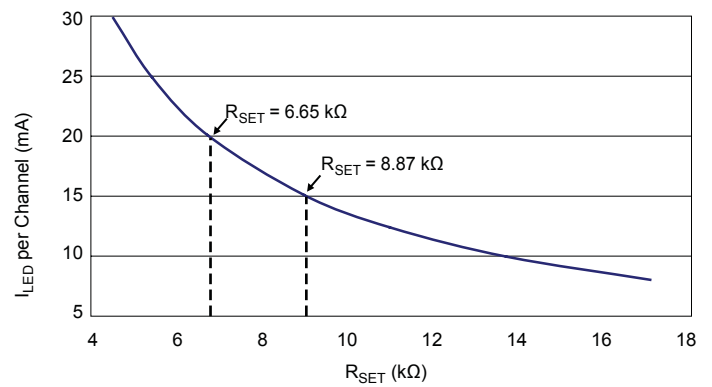

Dimming on ENM and ENS

Enable Pulses versus Total Current, LED1 through LED6

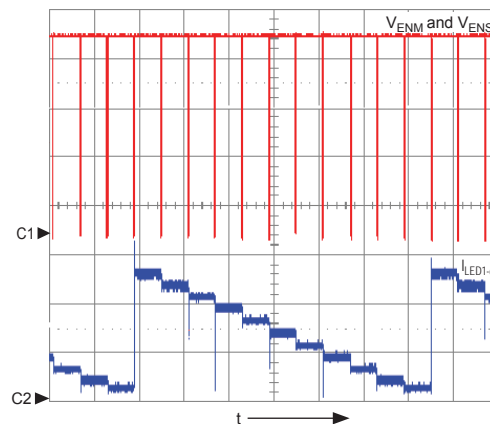

Symbol	Parameter	Units/Division
C1	V_{ENM}	0.5 V
C2	I_{LED1-6}	50 mA
t	time	50 ms

Performance Characteristics

Tests performed using application circuit shown in figure 2
 $T_A = 25^\circ\text{C}$, $V_{IN} = 3.6\text{ V}$ (unless otherwise noted)

Turn ON LED1 through LED6 to 1X Mode
 $V_{IN} = 4.0\text{ V}$, $I_{OUT} = 120\text{ mA}$, $V_F = 3.4\text{ V}$

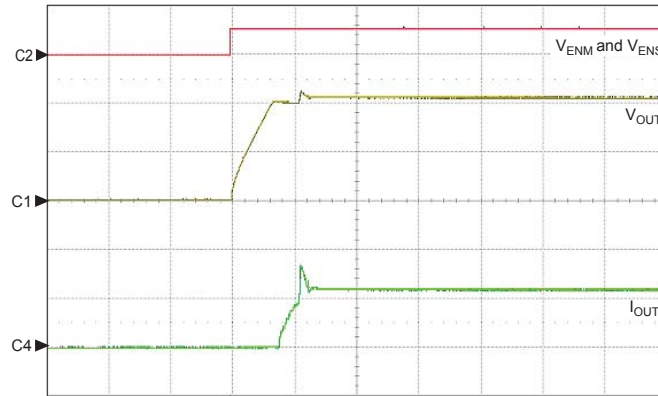

Symbol	Parameter	Units/Division
C2	V_{ENM} and V_{ENS}	5.00 V
C1	V_{OUT}	2.00 V
C4	I_{OUT}	100 mA
t	time	1 ms

Turn ON LED1 through LED6 to 1.5X Mode
 $V_{IN} = 3.0\text{ V}$, $I_{OUT} = 120\text{ mA}$, $V_F = 3.4\text{ V}$

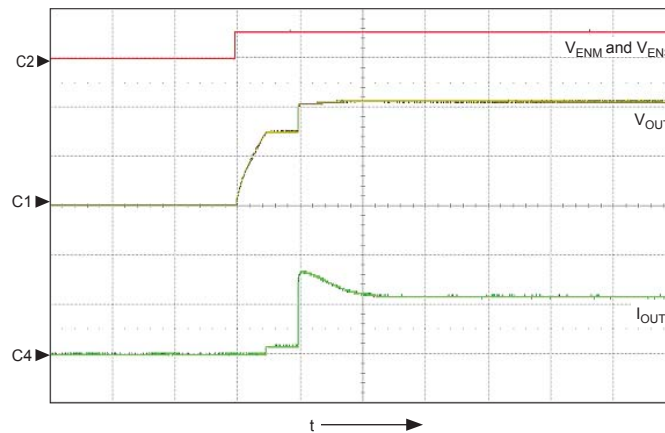

Symbol	Parameter	Units/Division
C2	V_{ENM} and V_{ENS}	5.00 V
C1	V_{OUT}	2.00 V
C4	I_{OUT}	100 mA
t	time	1 ms

Performance Characteristics

Tests performed using application circuit shown in figure 2
 $T_A = 25^\circ\text{C}$, $V_{IN} = 3.6\text{ V}$ (unless otherwise noted)

LED1 through LED6 ON, 2X Mode
 $V_{IN} = 2.7\text{ V}$, $I_{OUT} = 120\text{ mA}$, $V_F = 3.6\text{ V}$

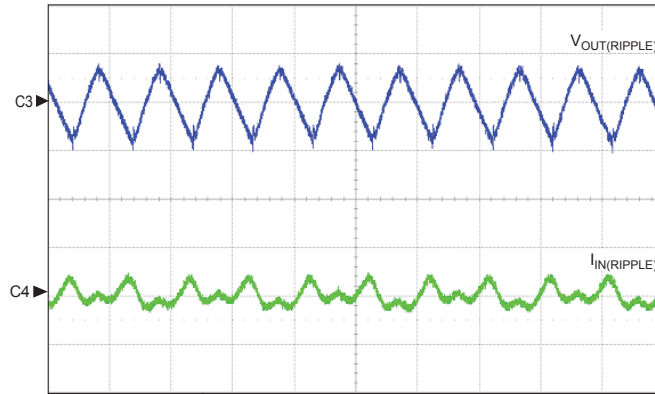

Symbol	Parameter	Units/Division
C3	$V_{OUT(RIPPLE)}$	50 mV
C4	$I_{IN(RIPPLE)}$	50 mA
t	time	500 ns

LED1 through LED6 ON, 1.5X Mode
 $V_{IN} = 3.6\text{ V}$, $I_{OUT} = 120\text{ mA}$, $V_F = 3.6\text{ V}$

LED1 through LED4 on, 1.5X Mode
 $V_{IN} = 3.6\text{ V}$, $I_{OUT} = 80\text{ mA}$, $V_F = 3.6\text{ V}$

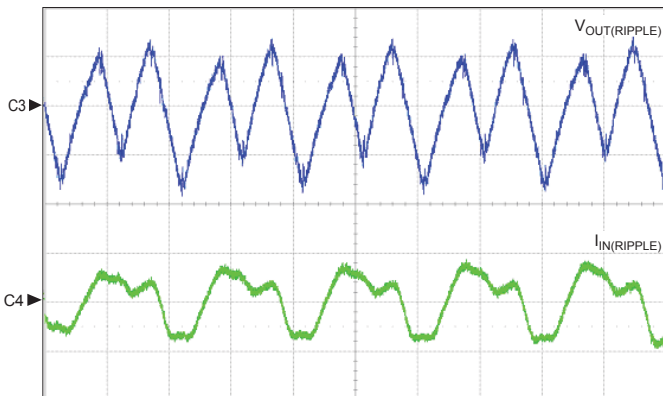

Symbol	Parameter	Units/Division
C3	$V_{OUT(RIPPLE)}$	20 mV
C4	$I_{IN(RIPPLE)}$	50 mA
t	time	500 ns

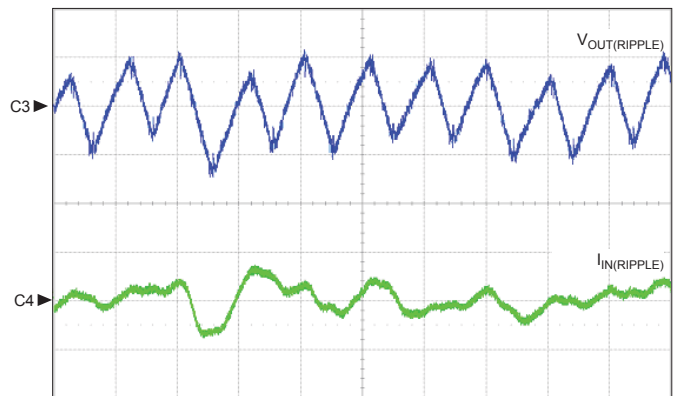

Symbol	Parameter	Units/Division
C3	$V_{OUT(RIPPLE)}$	20 mV
C4	$I_{IN(RIPPLE)}$	50 mA
t	time	500 ns

Application Information

Setting LED Current

Use the following formula to set the display backlight LED full current (100%) using RSET on LED1 through LED6. The maximum current through one LED should not exceed 30 mA:

$$R_{SET} = 0.6 \text{ V} \times 220 / I_{LEDx}$$

where R_{SET} is in Ω and I_{LEDx} in amperes.

Transitions Between 1× and 1.5× or 2× Modes

The A8434 adaptively selects operating mode. When V_{IN} is sufficiently high to maintain $V_{LEDx} > 150 \text{ mV}$, the A8434 operates in 1× mode unless, as V_{IN} drops, the $LEDx$ nodes fall below the 150 mV threshold. When V_{LEDx} falls below 150 mV, the IC enters 1.5× mode.

When the A8434 switches from 1× to 2× mode, it first switches to 1.5× mode for a typical duration of 1 ms before entering 2× mode.

When operating in 1.5× mode, if $V_{OUT} < V_{IN}$, then the IC switches back to 1× mode every 130 ms, and then reenters 1.5× mode again if necessary.

Transitions Between 1.5× and 2× Modes

The transition from 1.5× to 2× mode depends upon dropout conditions.

When operating in 2× mode, the IC switches back to 1.5× mode every 130 ms, and then reenters 2× mode again if necessary. Furthermore, when in 2× mode, whenever a channel disabling is sensed (that is, whenever ENM is held low for $> 0.5 \text{ ms}$ with ENF high, or vice versa), the IC automatically reverts to 1.5× mode, and then reenters 2× mode again if necessary.

Dimming

Main Display LED1 through LED4 Dimming. The main display WLEDs (LED1 through LED4) brightness and on/off can be controlled using digital input at the ENM pin. The ENM pin accepts one-wire serial pulse input to enable the A8434 and to set up to 11 dimming levels, from 100% down to 5%.

When ENM is initially pulled up from shutdown, after a soft-start, the current for the WLEDs is programmed to 100% of the setting current, which is determined by the current through the ISET pin. Each subsequent pulse reduces the backlight LEDs current by 10%, and the 10th pulse reduces the current by 5%. The next pulse restores 100% (full) brightness. Figure 5 shows the timing diagram for ENM control.

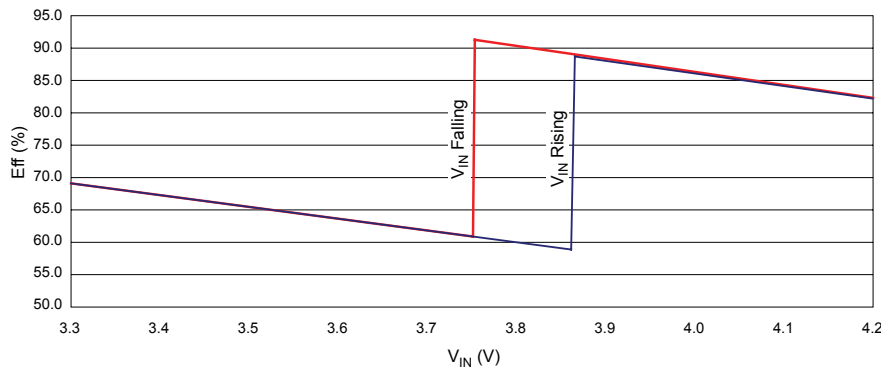

Figure 4. Mode change transition

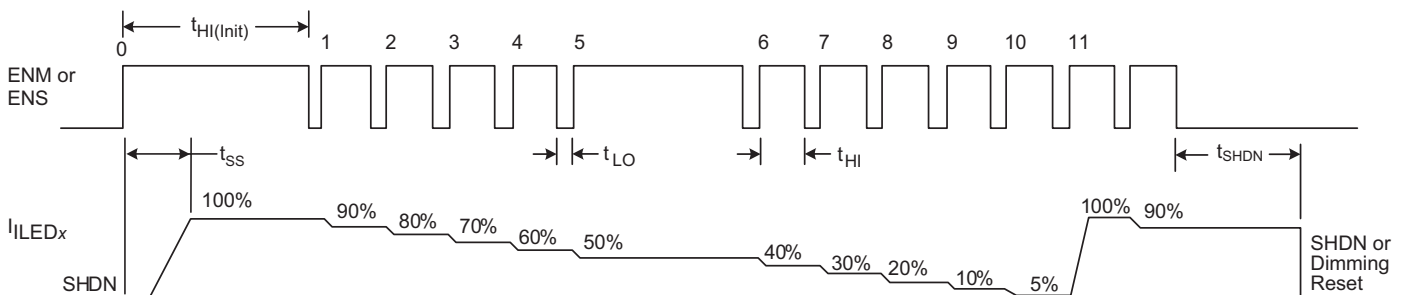

Figure 5. Single-Wire Serial Dimming Control; at pins ENM and ENS.

Sub Display LED5 and LED6 Operation. The sub display backlight LEDs (LED5 and LED6) brightness and on/off can be controlled using digital input at the ENS pin. The ENS pin accepts one-wire serial pulse input to enable the A8434 and to set up to 11 dimming levels, from 100% down to 5%.

When ENS is initially pulled up from shutdown, after a soft-start, the current for the backlight LEDs is programmed to 100% of the setting current, which is determined by the current through the ISET pin. Each subsequent pulse reduces the LED current by 10%, and the 10th pulse reduces the current by 5%. The next pulse restores 100% (full) brightness. Figure 5 shows the timing diagram for ENS control.

Simultaneous Dimming of All 6 LEDs

For larger displays 6 LEDs can be grouped together. The LEDs LED1 through LED6 can be dimmed simultaneously by connecting ENM and ENS together and applying serial pulses for dimming, as shown in figure 1.

Absolute Level Operation Some applications require dimming to a specific level, regardless of the present level of dimming.

For example, if the IC should dim to 30%, this can be done with 7 steps, as shown in figure 5, irrespective of the dimming level in effect. This can be achieved by pulling corresponding ENx pin low for time greater than t_{SHDN} and then applying pulses as shown in figure 5 (7 for 30% dimming). If the pulses are applied within 2-3 ms, the display flicker is not visible. The procedure is shown in figure 6.

Shutdown

When the ENM or ENS pin is pulled low for 0.5 ms or longer, the corresponding display channels are shut off and dimming is reset to 100% upon the next ENM or ENS going high edge. When both ENM and ENS are pulled low for 0.5 ms or longer, the A8434 enters the shutdown mode.

Short Circuit Protection

The A8434 is protected against short circuits on the output. When V_{OUT} is externally pulled below 1.2 V, the IC enters short circuit mode. The A8434 resumes normal operation when the short circuit is removed.

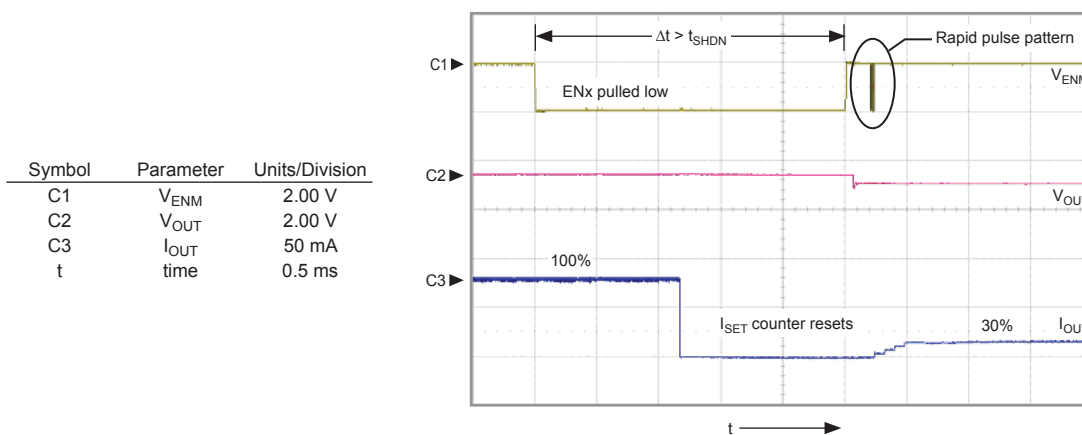

Figure 6. Absolute Dimming Level Setting. With ENM pulled low longer the t_{SHDN} , pulsing the corresponding ENx pin sets an absolute target level.

Overvoltage Protection

The A8434 is protected up to 4.9 V supply voltage, against accidental overvoltage caused by an open LED. When any LED opens, V_{OUT} will increase till 6 V. Remaining LEDs will continue to function normally. Normal operation will be resumed when the fault is removed.

LED Disconnection

Every LEDx pin has a disable subcircuit, as shown in figure 7. The A8434 compares the voltage on each LED pin, and if the voltage on the pin is greater than either $V_{OUT} - 0.4$ V or $V_{IN} - 0.4$ V, then the corresponding LED pin is disabled.

If any WLED is not used, connect the corresponding pin to VOUT. Never leave open any unused WLED pin. LED pins will sink 20 μ A typical when connected to VOUT and the corresponding LED group (main or sub) is enabled.

Note: In shutdown mode ($ENM = ENS = 0$ V for > 0.5 ms), the total leakage current is $< 1 \mu$ A.

Thermal Shutdown

The IC is internally protected against overtemperature. The overtemperature limit is set to 165°C nominal. The IC shuts down when the junction temperature exceeds 165°C and automatically turns on again when the IC cools.

Component Selection

Ceramic capacitors with X5R or X7R dielectric are recommended for the input capacitor, CIN, the output capacitor, COUT, and the charge pump capacitors, C1 and C2.

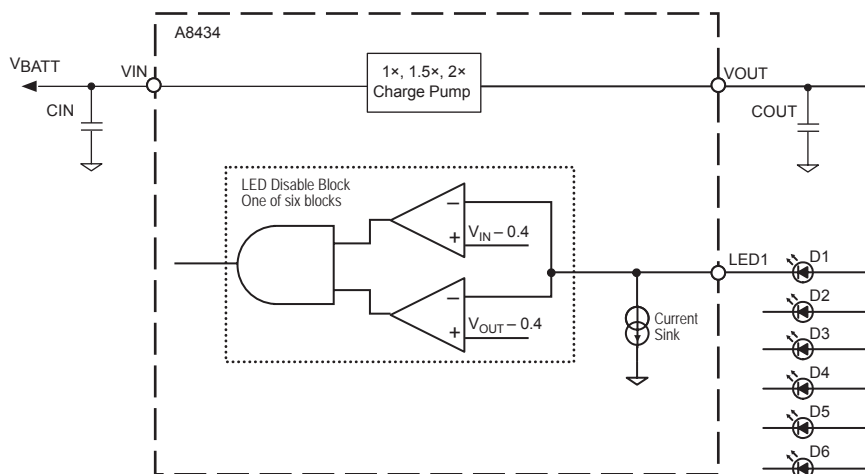



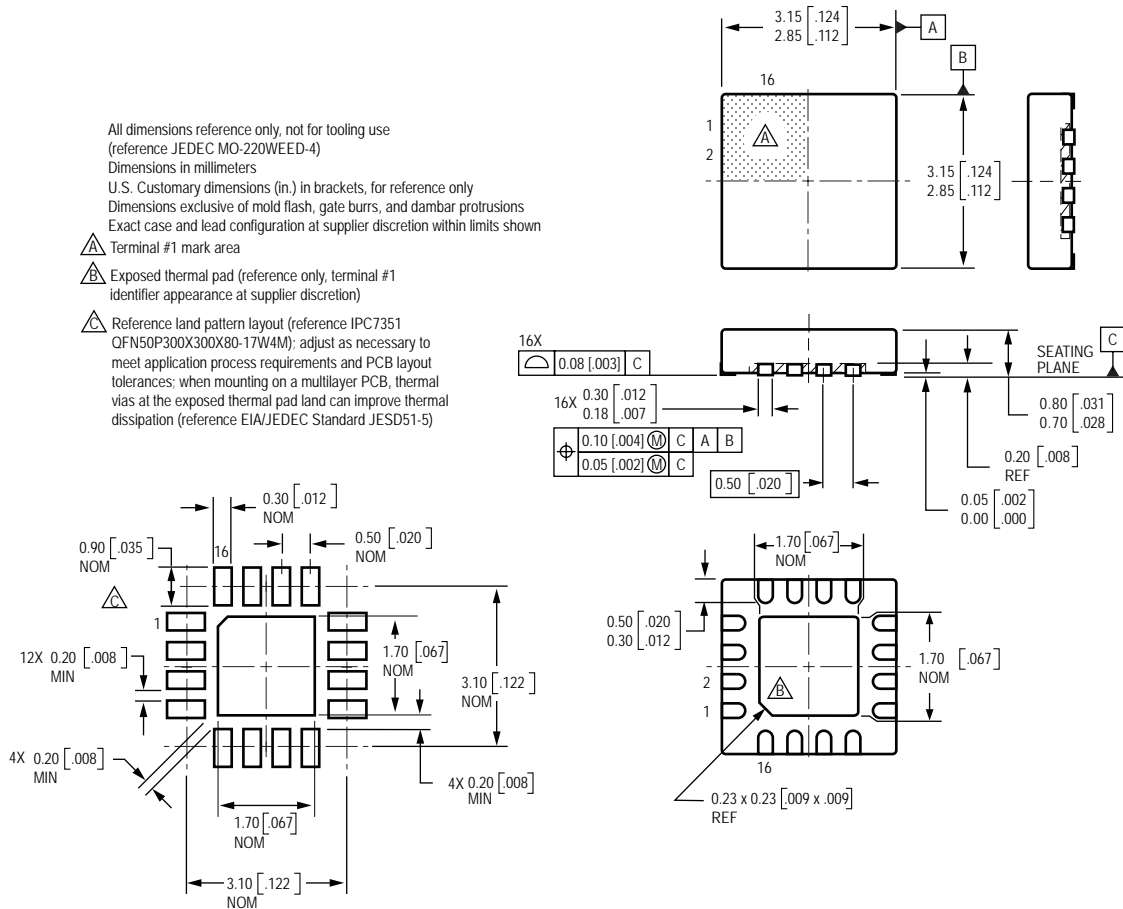

Figure 7. LED disable subcircuit. Subcircuit for one LEDx pin shown. A similar block is connected to each LEDx pin.

Package ES, 3 × 3 mm 16-Pin QFN/MLP

All dimensions reference only, not for tooling use
(reference JEDEC MO-220WEED-4)
Dimensions in millimeters
U.S. Customary dimensions (in.) in brackets, for reference only
Dimensions exclusive of mold flash, gate burrs, and dambar protrusions
Exact case and lead configuration at supplier discretion within limits shown

-  Terminal #1 mark area
-  Exposed thermal pad (reference only, terminal #1 identifier appearance at supplier discretion)
-  Reference land pattern layout (reference IPC7351 QFN50P300X300X80-17W4M); adjust as necessary to meet application process requirements and PCB layout tolerances; when mounting on a multilayer PCB, thermal vias at the exposed thermal pad land can improve thermal dissipation (reference EIA/JEDEC Standard JESD51-5)



Copyright ©2006, Allegro MicroSystems, Inc.

The products described here are manufactured under one or more U.S. patents or U.S. patents pending.

Allegro MicroSystems, Inc. reserves the right to make, from time to time, such departures from the detail specifications as may be required to permit improvements in the performance, reliability, or manufacturability of its products. Before placing an order, the user is cautioned to verify that the information being relied upon is current.

Allegro's products are not to be used in life support devices or systems, if a failure of an Allegro product can reasonably be expected to cause the failure of that life support device or system, or to affect the safety or effectiveness of that device or system.

The information included herein is believed to be accurate and reliable. However, Allegro MicroSystems, Inc. assumes no responsibility for its use; nor for any infringement of patents or other rights of third parties which may result from its use.

For the latest version of this document, visit our website:

www.allegromicro.com

