

REVISIONS			
LTR.	DESCRIPTION	DATE	APPROVED
A	NEW DRAWING	3/00	

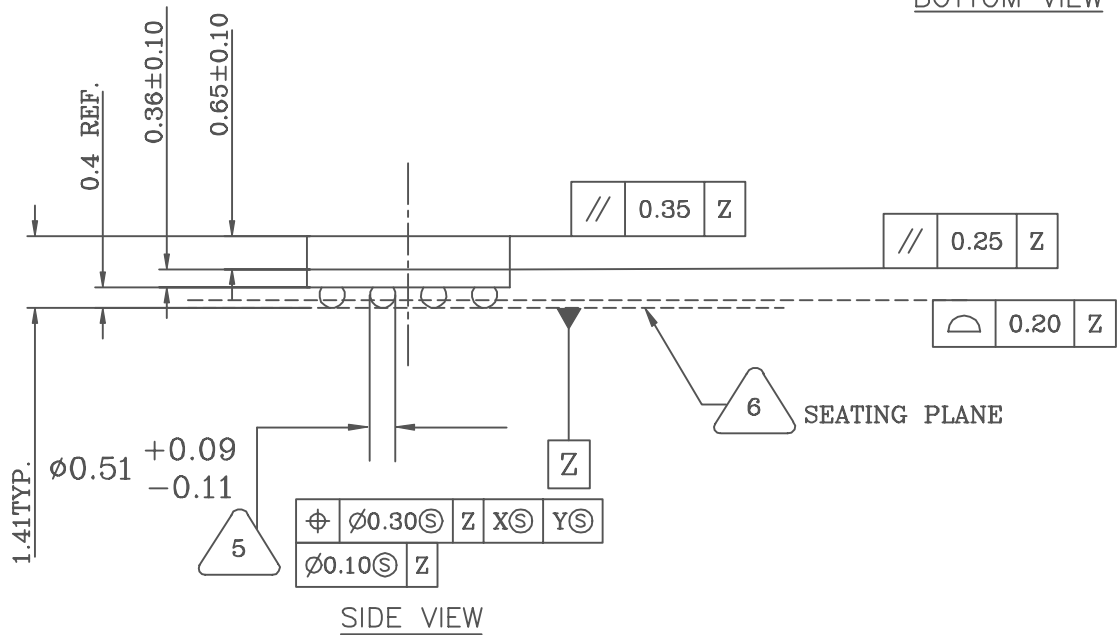
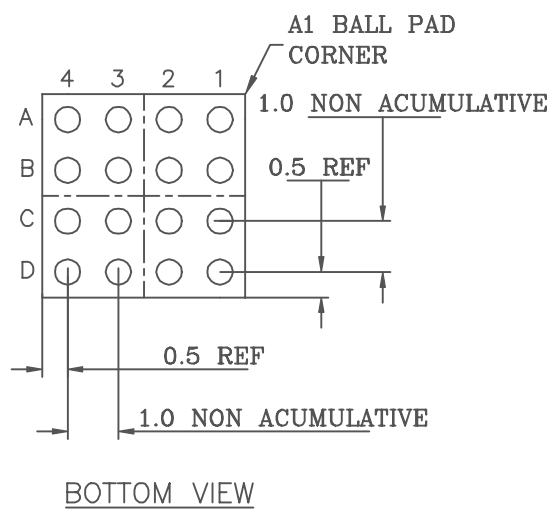
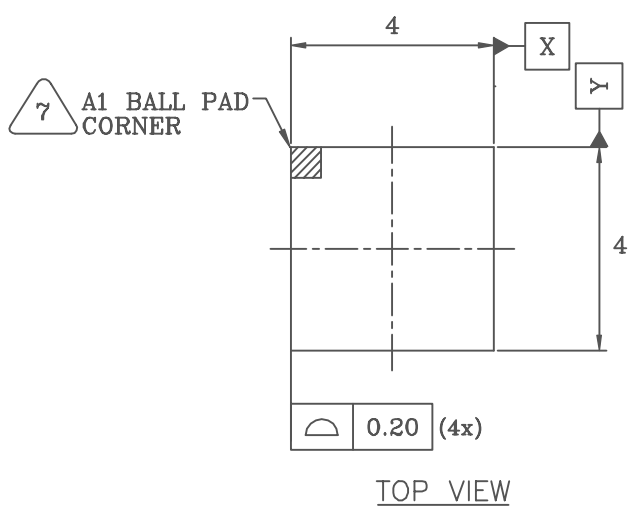

NOTES:

- 7. A1 BALL PAD CORNER I.D. IS IDENTIFIED BY LASER MARKED DOT AT THE CORNER.
- 6. PRIMARY DATUM Z AND SEATING PLANE ARE DEFINED BY THE SPHERICAL CROWNS OF THE SOLDER BALLS.
- 5. DIMENSION IS MEASURED AT THE MAXIMUM SOLDER BALL DIAMETER, PARALLEL TO PRIMARY DATUM Z.
- 4. BILATERAL TOLERANCE ZONE IS APPLIED TO EACH SIDE OF THE PACKAGE BODY.
- 3. SOLDER BALL POSITION DESIGNATION PER JESD 95-1, SPP-010.
- 2. ALL DIMENSIONS AND TOLERANCES CONFORM TO ANSI Y14.5M-1994.
- 1. ALL DIMENSIONS ARE IN MILLIMETERS

SIGNATURE		DATE					
DOC. CONTROL:							
ENGR. MGR:				SIZE	FSCM NO.	PART NO.	REV.
MFG. ENGR:				A		56-G6005-001	A
CHECKED BY:		DATE		SCALE			
TWM		3/00		N/A			
DRAWN BY:		DATE		SHEET			
NLK		3/00		1 of 1			
DO NOT SCALE DRAWING							