

White LED Driver with 1X /1.5X

High-Efficiency Charge Pump

DESCRIPTION

The EUP2794 is a low noise, constant frequency charge pump that uses a dual mode load switch (1X) and fractional (1.5X) conversion to maximize efficiency for white LED applications. The EUP2794 delivers up to 80mA of load current and provides four regulated current sources, each capable of driving up to 20mA through white LEDs. All LED pin currents are regulated, constant and tightly matched to achieve uniformity of brightness across the LCD backlight. The switching frequency is 900kHz.(typ.) to keep the conducted noise spectrum away from sensitive frequencies within portable RF devices.

An external resistor (R_{SET}) sets the current in each of the LED outputs. In addition, brightness can be controlled by both linear and PWM techniques. An analog voltage between 0V and 3.0V may be applied to the BRGT pin to linearly vary the LED current. By adjusting current with BRGT pin, the brightness of the LEDs can be smoothly varied. Alternatively, a PWM digital signal can be applied to the SD pin to vary the perceived brightness of the LED.

The EUP2794 is available in a 16-pin 3mm × 3mm QFN package.

FEATURES

- Regulated Current Sources with 0.6% Mis-matching between any Two Outputs
- High Efficiency 1.5X Charge Pump
- Drives One, Two, Three or Four White LEDs
- 2.7V to 5.5V Input Voltage
- Up to 80mA Output Current
- Analog or PWM Brightness Control
- Soft Start Function
- Low Shutdown Current
- 900kHz Switching Frequency (typ.)
- Tiny 3mm × 3mm QFN-16 Package
- RoHS Compliant and 100% Lead(Pb)-Free

APPLICATIONS

- White LED Backlighting
- 1-Cell Li-Ion battery-operated equipment including PDAs, hand-held PCs, cellular phones

Typical Application Circuit

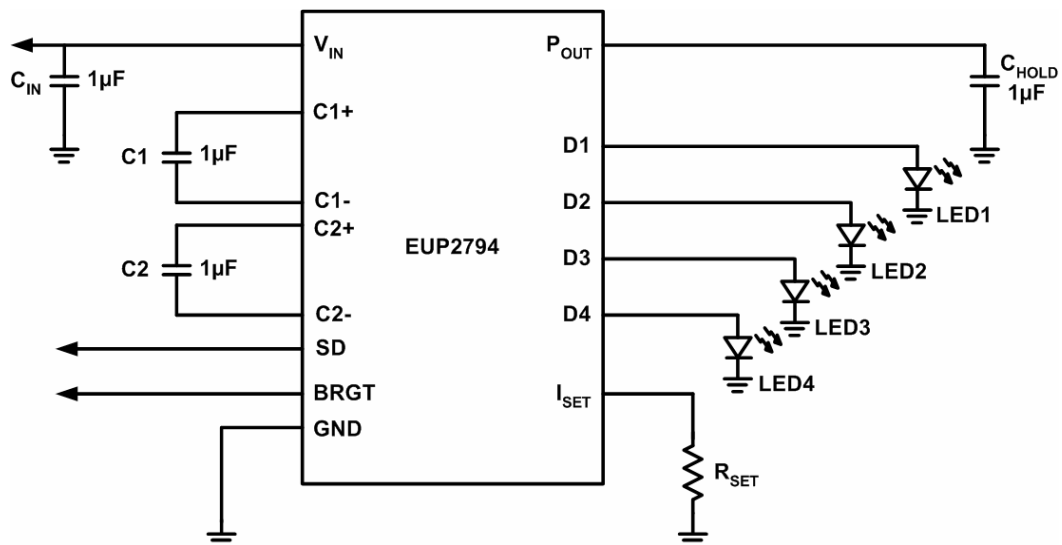

Figure 1.

Typical Application Circuit

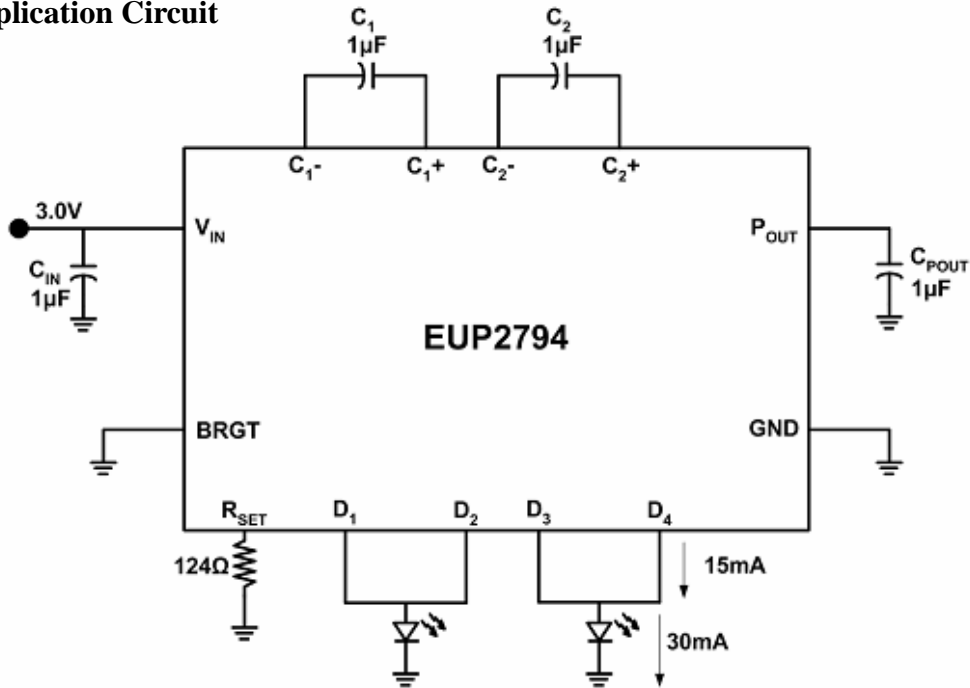

Figure 2.

Pin Configurations

| Part Number | Pin Configurations |
|-------------------|--------------------|
| EUP2794 QFN-16 | |

Pin Description

| PIN | Pin | DESCRIPTION |
|------------------|----------|--|
| C2P | 1 | Positive terminal of C2 |
| P _{OUT} | 2 | Charge pump output |
| SD | 3 | Active-low shutdown pin (LOW=shutdown, HIGH=operating). |
| BRGT | 5 | Variable voltage input controls output current |
| I _{SET} | 6 | Current sense input. Connect 1% resistor to ground to set constant current through LED |
| LED1-4 | 8,7,10,9 | Current source outputs. Connect directly to LED |
| GND | 11 | Power supply ground input |
| C1N | 13 | Negative terminal of C1 |
| VIN | 14 | Power supply voltage input |
| C2N | 15 | Negative terminal of C2 |
| C1P | 16 | Positive terminal of C1 |

Ordering Information

| Order Number | Package Type | Marking | Operating Temperature range |
|----------------------------|--------------|---------------|-----------------------------|
| EUP2794JIR1 EUP2794JIR0 | QFN-16 | XXXX 2794A | -40 °C to 85°C |

EUP2794-

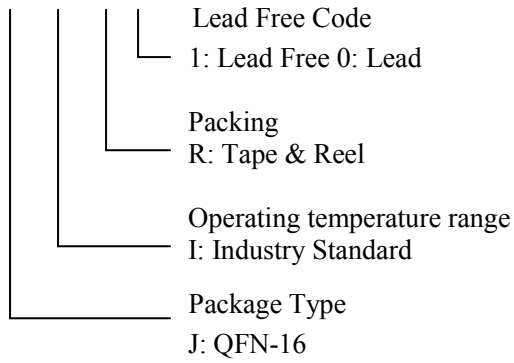

Block Diagram

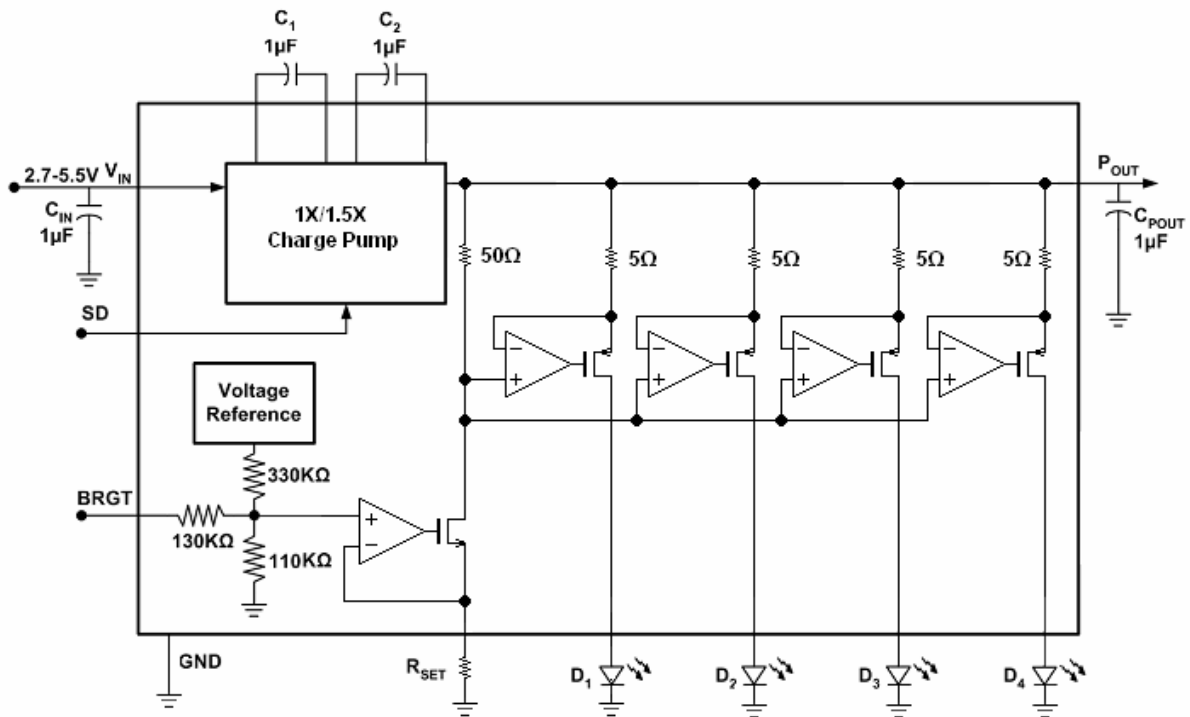

Figure 3.

Absolute Maximum Ratings

- V_{IN} ----- -0.3V to 6V max
- SD,BRGT ----- -0.3V to ($V_{IN}+0.3V$) w/ 6 max
- Continuous Power Dissipation ----- Internally Limited
- QFN-16L 3×3, θ_{JA} ----- 65°C/W
- Junction Temperature (T_J) ----- -40°C to 125°C
- Storage Temperature Range ----- -65°C to 150°C
- Lead Temp (Soldering, 5sec) ----- 260°C
- ESD Rating
Human Body Model ----- 2kV

Operating Conditions

- Input Voltage (V_{IN}) ----- 2.7V to 5.5V
- Ambient Temperature (T_A) ----- -40°C to 85°C

Electrical Characteristics

Unless otherwise specified, $C_1=C_2=C_{IN}=C_{HOLD}=1\mu F$, $V_{IN}=3.6V$, BRGT pin =0V ; $R_{SET}=124$; $V_{LED}=3.4V$.
 $T_A=-40$ to 85°C. Typical values are at $T_A=25^\circ C$.

| Symbol | Parameter | Conditions | EUP2794 | | | Unit |
|---------------|--|--|-----------|-------------|-------------|------------|
| | | | Min | Typ | Max. | |
| I_{DX} | Available Current at Output Dx | $3.0V \leq V_{IN} \leq 5.5V, V_{DX} \leq 3.6V$ BRGT=50mV | 15 | 17.12 | | mA |
| | | $2.7V \leq V_{IN} \leq 3.0V, V_{DX} \leq 3.4V$ BRGT=0V | 10 | 15.39 | | |
| | | $V_{DX} \leq 3.6V, BRGT=200mV$ | 20 | | | |
| V_{DX} | Available Voltage at Output Dx | $3.0V \leq V_{IN} \leq 5.5V, V_{DX} \leq 3.6V$ BRGT=50mV | | | 3.6 | V |
| I_{DX} | Liner Regulation of Dx Output Current | $3.0V \leq V_{IN} \leq 5.5V, V_{DX} \leq 3.6V$ | | 15.57 | | mA |
| I_{DX} | Load Regulation of Dx Output Current | $V_{IN}=3.6V, 3.0V \leq V_{DX} \leq 3.6V$ | | 15.57 | | mA |
| $I_{D-MATCH}$ | Current Matching Between Any Two Outputs | $V_{IN}=3.6V$ | | 0.6 | | % |
| I_Q | Quiescent Supply current | $3.0V \leq V_{IN} \leq 5.5V$, Active, No Load Current $R_{SET}=OPEN$ | | 4.1 | 7.64 | mA |
| I_{SD} | Shutdown Supply Current | $3.0V \leq V_{IN} \leq 5.5V$, shutdown | | | 1 | μA |
| V_{CP} | Input Charge-Pump Mode To Pass Mode Threshold | | | 3.82 | | V |
| V_{CPH} | Input Charge-Pump Mode To Pass Mode Hysteresis | | | 50 | | mV |
| V_{IH} | SD Input Logic High | $3.0V \leq V_{IN} \leq 5.5V$ | 1 | | | V |
| V_{IL} | SD Input Logic Low | $3.0V \leq V_{IN} \leq 5.5V$ | | | 0.2 | V |
| $I_{LEAK-SD}$ | SD Leakage Current | $0V \leq V_{SD} \leq V_{IN}$ | -1 | | 1 | μA |
| R_{BRGT} | BRGT Input Resistance | | | 240 | | k Ω |
| I_{SET} | I_{SET} Pin Output Current | | | $I_{DX}/10$ | | mA |
| f_{SW} | Switching Frequency | $3.0V \leq V_{IN} \leq 3.8V$ | | 900 | | kHz |

Typical Operating Characteristics

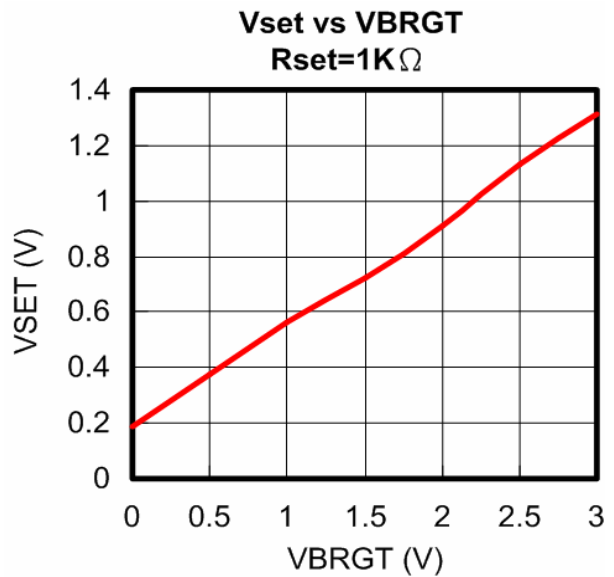
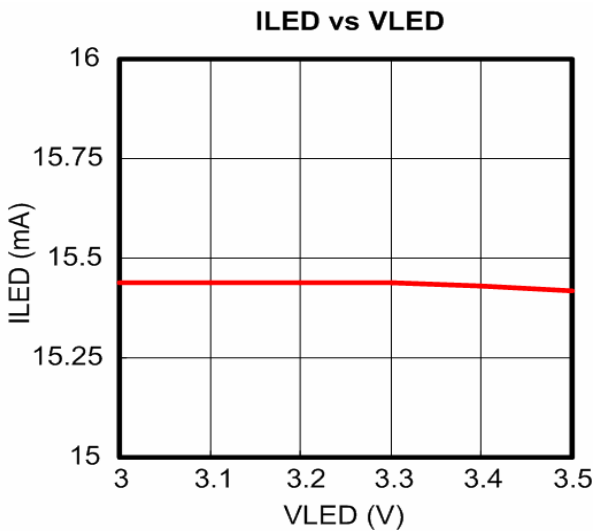
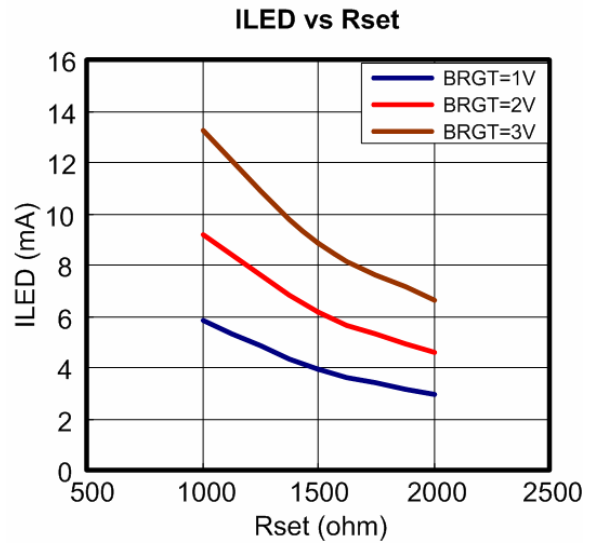
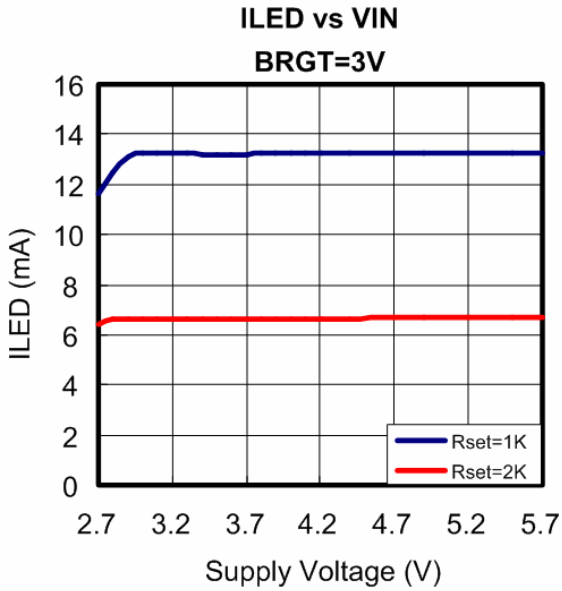
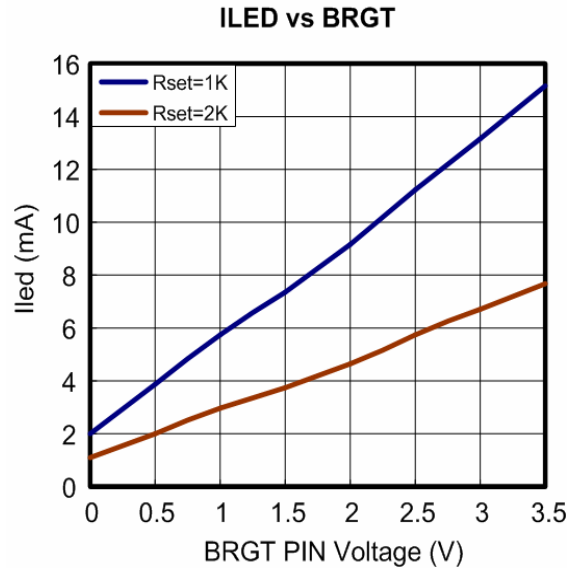
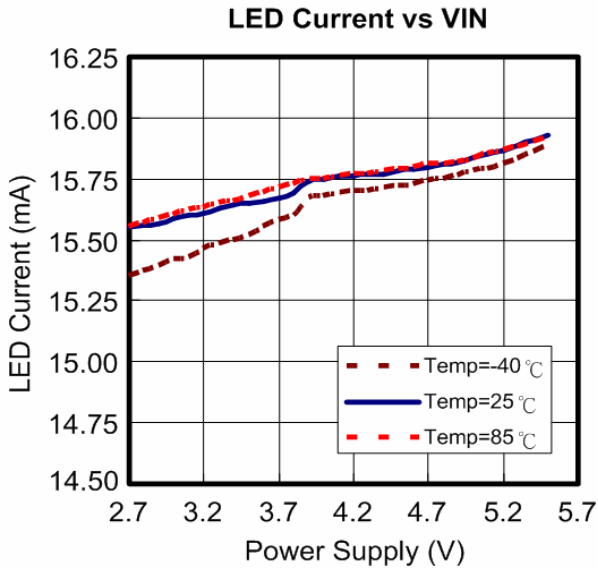

Duty Cycle vs LED Current
ILED 1-4=15.5mA

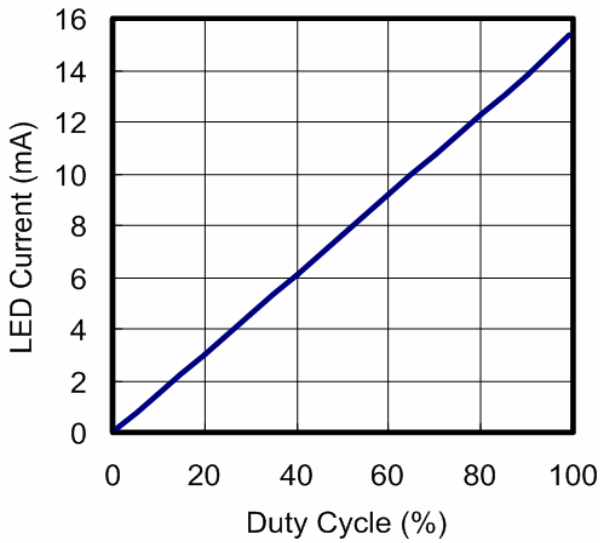

Supply Current vs VIN
ILED 1-4=15.5mA

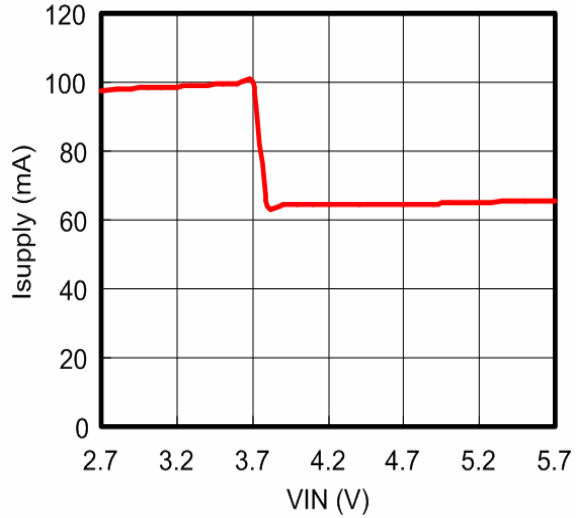

Supply Current vs VIN
ILED 1-4=OPEN

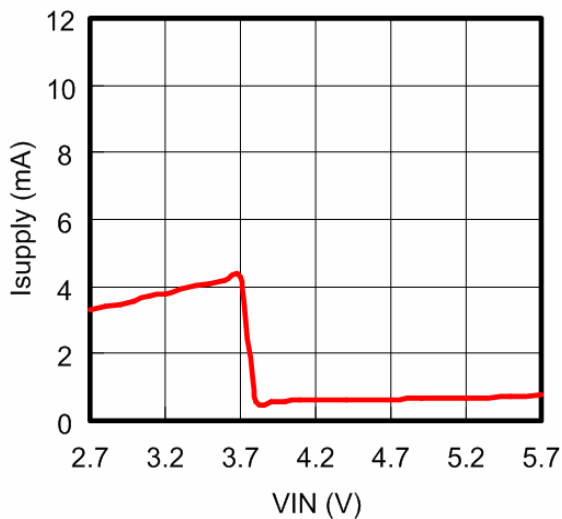

LED Current vs Temperature

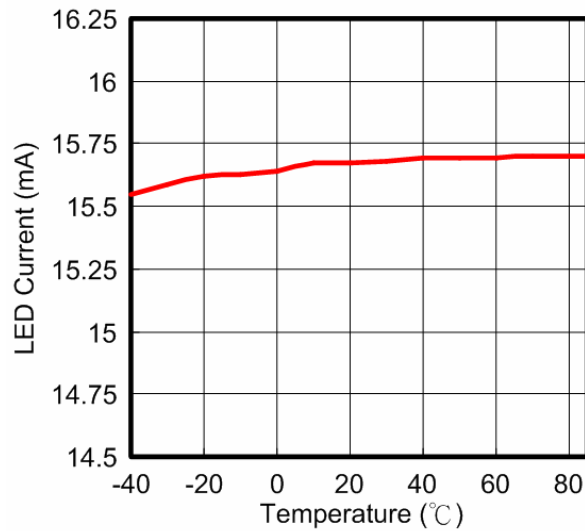

Shutdown Threshold vs VIN

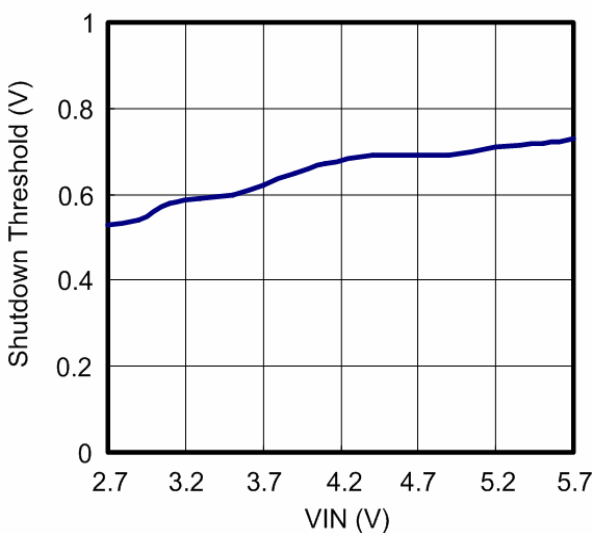

Switching Frequency vs VIN

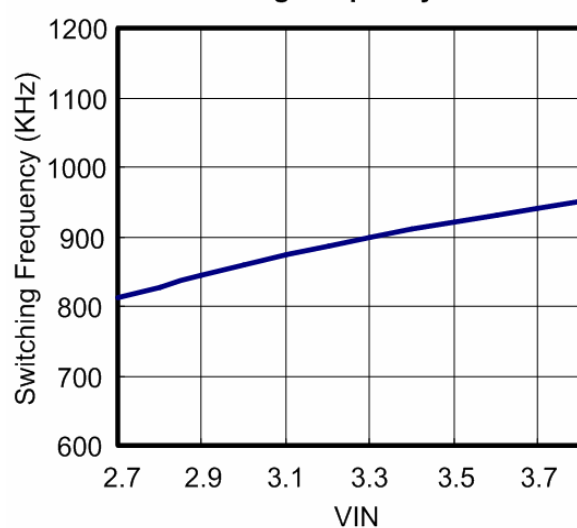

Start-Up Response @VIN=2.7V

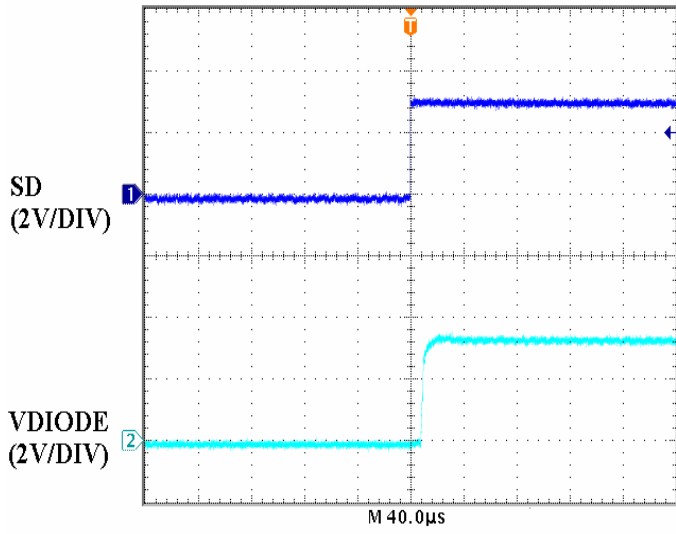

Start-Up Response @VIN=3.6V

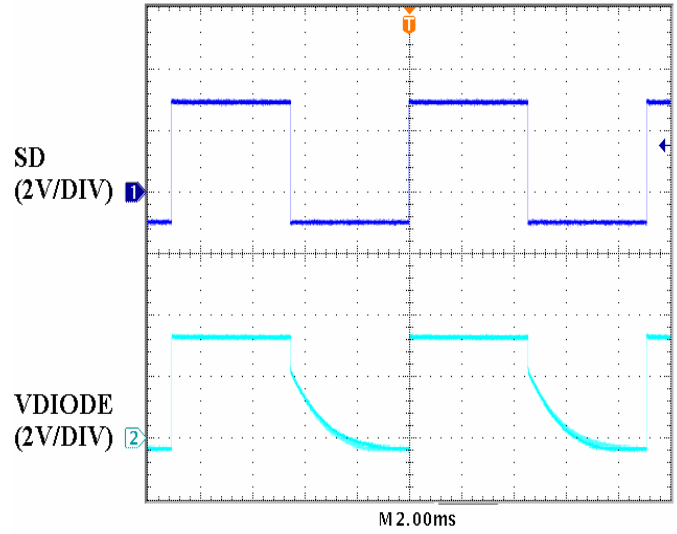

Start-Up Response @VIN=4.2V

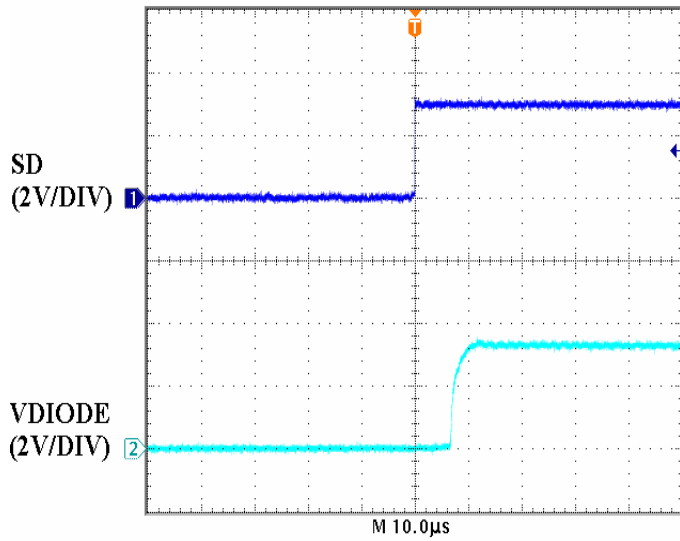

Application Information

Circuit Description

The EUP2794 has four regulated current sources connected to the device's 1.5x charge pump output (P_{OUT}). At input voltages below 3.82V (typ.), the charge-pump provides the needed voltage to drive high forward voltage drop White LEDs. It does this by stepping up the P_{OUT} voltage 1.5 times the input voltage. The charge pump operates in Pass Mode, providing a voltage on P_{OUT} equal to the input voltage, when the input voltage is at or above 3.82V (typ.). The device can drive up to 80mA through any combination of LEDs connected to the constant current outputs D1-D4. To set the LED drive current, the device uses a resistor connected to the I_{SET} pin to set a reference current. This reference current is then multiplied and mirrored to each constant current output. The LED brightness can then be controlled by analog and/or digital methods. Applying an analog voltage in the range of 0V to 3.0V to the Brightness pin (BRGT) adjusts the dimming profile of the LEDs. The digital technique uses a PWM (Pulse Width Modulation) signal applied to the Shutdown pin (SD). (see **I_{SET} and BRGT PINS** section).

Soft-Start

Soft start is implemented internally by limiting the current flow through the charge pump switches. During soft start, the input current and LED current will ramp up slowly and avoid current inrush.

Shutdown Mode

The shutdown pin (SD) disables the part and reduces the quiescent current less than 1 μ A (typ.). The EUP2794 has an active-low shutdown pin (LOW = shutdown, HIGH = operating). The EUP2794 SD pin can be driven with a low-voltage CMOS logic signal (1.5V logic, 1.8V logic, etc). There is no internal pull-up or pull-down on the SD pin of the EUP2794.

Capacitor Selection

The EUP2794 requires 4 external capacitors for proper operation. Surface-mount multi-layer ceramic capacitors are recommended. These capacitors are small, inexpensive and have very low equivalent series resistance (ESR, 15m Ω . typ.). Tantalum capacitors, OS-CON capacitors, and aluminum electrolytic capacitors are generally not recommended for use with the EUP2794 due to their high ESR, as compared to ceramic capacitors. For most applications, ceramic capacitors with X7R or X5R temperature characteristic are preferred for use with the EUP2794. These capacitors have tight capacitance tolerance (as good as $\pm 10\%$), hold their value over temperature (X7R: $\pm 15\%$ over -55°C to 125°C ; X5R: $\pm 15\%$ over -55°C to 85°C), and typically have little voltage coefficient.

I_{SET} and BRGT Pins

An external resistor, R_{SET} , is connected to the I_{SET} pin to set the current to be mirrored in each of the LED outputs. The internal current mirror sets each LED output current with a 10:1 ratio to the current through R_{SET} . The current mirror circuitry matches the current through each LED to within 0.6%.

In addition to R_{SET} , a voltage may be applied to the V_{BRGT} in to vary the LED current. By adjusting current with the Brightness pin (BRGT), the brightness of the LEDs can be smoothly varied.

Applying a voltage on BRGT between 0 to 3 volts will linearly vary the LED current. Voltages above 3V do not increase the LED current any further. The voltage on the V_{BRGT} pin is fed into an internal resistor network with a ratio of 0.385. The resulting voltage is then summed with a measured offset voltage of 0.188V, which comes from the reference voltage being fed through a resistor network (See **Functional Block Diagram**). The brightness control circuitry then uses the summed voltage to control the voltage across R_{SET} . An equation for approximating the LED current is:

$$I_{LED} = \left(\frac{V_{OFFSET} + (V_{BRGT} * 0.385)}{R_{SET}} \right) * (\text{Mirror Ratio})$$

$$I_{LED} = \left(\frac{0.188 + (V_{BRGT} * 0.385)}{R_{SET}} \right) * \frac{10}{1} \text{ Amps}$$

I_{LED} Current Selection Procedures

The following procedures illustrate how to set and adjust output current levels. For constant brightness or analog brightness control, go to “Brightness control using BRGT”. Otherwise refer to “Brightness control using PWM”.

Brightness Control Using PWM

1. Set the BRGT pin to 0V
2. Determine the maximum desired I_{LED} current. Use the I_{LED} equation to calculate R_{SET} by setting BRGT to 0V or use Table 1 to select a value for R_{SET} when BRGT equals 0V.
3. Brightness control can be implemented by pulsing a signal at the SD pin. LED brightness is proportional to the duty cycle (D) of the PWM signal. For linear brightness control over the full duty cycle adjustment range, the PWM frequency (f) should be limited to accommodate the turn-on time (T_{ON} = 100µs) of the device.

$$D * (1/f) > T_{ON}$$

$$f_{MAX} = D_{MIN} \div T_{ON}$$

If the PWM frequency is much less than 100Hz, flicker may be seen in the LEDs. For the EUP2794, zero duty cycle will turn off the LEDs and a 50% duty cycle will result in an average I_{LED} being half of the programmed LED current. For example, if R_{SET} is set to program 15mA, a 50% duty cycle will result in an average I_{LED} of 7.5mA.

Brightness Control Using BRGT

1. Choose the maximum I_{LED} desired and determine the max voltage to be applied to the BRGT pin. For constant brightness, set BRGT to a fixed voltage between 0V to 3V.
2. Use Table 1 to determine the value of R_{SET} required or use the I_{LED} equation above to calculate R_{SET}.
3. Use Table 2 as a reference for the dimming profile of the LEDs, when BRGT ranges from 0V to 3V

TABLE 1. R_{SET} Values

| BRGT | LED Current | | | |
|------|-------------|--------|-------|-------|
| | 5mA | 10mA | 15mA | 20mA |
| 0.0V | 375.0 | 185.2 | 122.8 | 91.9 |
| 0.5V | 760.0 | 376.0 | 250.6 | 187.8 |
| 1.0V | 1.139K | 567.0 | 375.0 | 282.2 |
| 1.5V | 1.526K | 752.0 | 503.0 | 375.0 |
| 2.0V | 1.9K | 939.0 | 625.0 | 467.0 |
| 2.5V | 2.32K | 1.129K | 756.0 | 565.0 |
| 3.0V | 2.663K | 1.319K | 881.0 | 660.0 |

TABLE 2. LED Current

| BRGT | R _{SET} Values | | | |
|------|-------------------------|-------|-------|-------|
| | 2.66K | 1.32K | 881 | 660 |
| 0.0V | 0.82 | 1.52 | 2.20 | 2.88 |
| 0.5V | 1.51 | 2.92 | 4.31 | 5.71 |
| 1.0V | 2.21 | 4.36 | 6.47 | 8.59 |
| 1.5V | 2.91 | 5.73 | 8.57 | 11.39 |
| 2.0V | 3.60 | 7.20 | 10.72 | 14.22 |
| 2.5V | 4.29 | 8.64 | 12.81 | 17.07 |
| 3.0V | 5.01 | 10.02 | 15.00 | 20.00 |

Charge Pump Output (P_{OUT})

The EUP2794 charge pump is an unregulated switched capacitor converter with a gain of 1.5. The voltage at the output of the pump (the P_{OUT} pin) is nominally 1.5 × V_{IN}. This rail can be used to deliver additional current to other circuitry. A ballast resistor sets the current through each LED, and LED current matching is dependent on the LED forward voltage matching. Because of this, LEDs driven by P_{OUT} are recommended for functions where brightness matching is not critical, such as keypad backlighting.

LED Headroom Voltage (V_{HR})

Four current sources are connected internally between P_{OUT} and D1-D4. The voltage across each current source, ($V_{POUT} - V_{DX}$), is referred to as headroom voltage (V_{HR}). The current sources require a sufficient amount of headroom voltage to be present across them in order to regulate properly. Minimum required headroom voltage is proportional to the current flowing through the current source, as dictated by the equation:

$$V_{HR-MIN} = k_{HR} \times I_{DX}$$

The parameter k_{HR} , typically 20mV/mA in the EUP2794, is a proportionality constant that represents the ON-resistance of the internal current mirror transistors. For worst-case design calculations, using a k_{HR} of 25mV/Ma is recommended. (Worst-case recommendation accounts for parameter shifts from part-to-part variation and applies over the full operating temperature range). Figure 4 shows how output current of the EUP2794 varies with respect to headroom voltage.

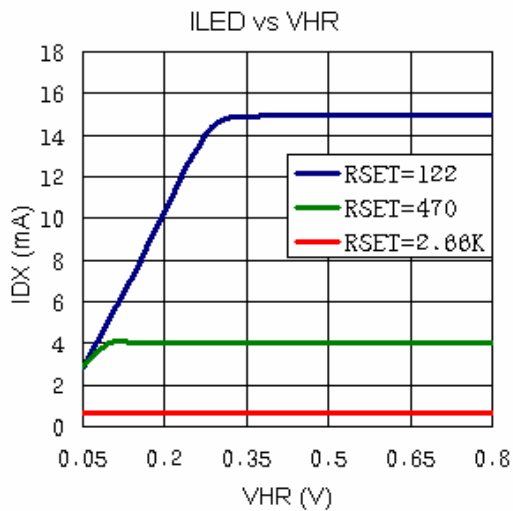

Figure 4. I_{LED} vs V_{HR} 4 LEDs, $V_{IN}=3.0V$

On the flat part of the graph, the currents regulate properly as there is sufficient headroom voltage for regulation. On the sloping part of the graph the headroom voltage is too small, the current sources are squeezed, and their current drive capability is limited. Changes in headroom voltage from one output to the next, possible with LED forward voltage mismatch, will result in different output currents and LED brightness mismatch. Thus, operating the EUP2794 with insufficient headroom voltage across the current sources should be avoided.

Output Current Capability

The primary constraint on the total current capability is the headroom voltage requirement of the internal current sources. Combining the V_{POUT} and V_{HR} equations from the previous two sections yields the basic inequality for determining the validity of an EUP2794 LED-drive application:

$$V_{POUT} = 1.5 \times V_{IN} - I_{TOTAL} \times R_{OUT}$$

$$V_{HR-MIN} = k_{HR} \times I_{DX}$$

$$V_{POUT} - V_{DX} \geq V_{HR-MIN}$$

$$1.5 \times V_{IN} - I_{TOTAL} \times R_{OUT} - V_{DX} \geq (K_{HR} \times I_{DX})$$

Rearranging this inequality shows the estimated total output current capability of an application:

$$I_{TOTAL} \leq \left[\frac{(1.5 \times V_{IN-MIN}) - V_{DX-MAX}}{(K_{HR} \times I_{DX})} \right] \div R_{OUT}$$

Examining the equation above, the primary limiting factors on total output current capability are input and LED forward voltage. A low input voltage combined with a high LED voltage may result in insufficient headroom voltage across the current sources, causing them to fall out of regulation. When the current sources are not regulated, LED currents will be below desired levels and brightness matching will be highly dependent on LED forward voltage matching.

Typical EUP2794 output resistance is 3.0Ω. For worst-case design calculations, using an output resistance of 3.5Ω is recommended. EUP2794 has a typical k_{HR} constant of 20mV/mA. For worst-case design calculations, use $k_{HR} = 25mV/mA$. (Worst-case recommendations account for parameter shifts from part-to-part variation and apply over the full operating temperature range). R_{OUT} and k_{HR} increase slightly with temperature, but losses are typically offset by the negative temperature coefficient properties of LED forward voltages. Power dissipation and internal self-heating may also limit output current capability but is discussed in a later section.

Parallel Dx Outputs for Increased Current Drive

Outputs D₁ through D₄ may be connected together in any combination to drive higher currents through fewer LEDs. For example in Figure 5, outputs D₁ and D₂ are connected together to drive one LED while D₃ and D₄ are connected together to drive a second LED.

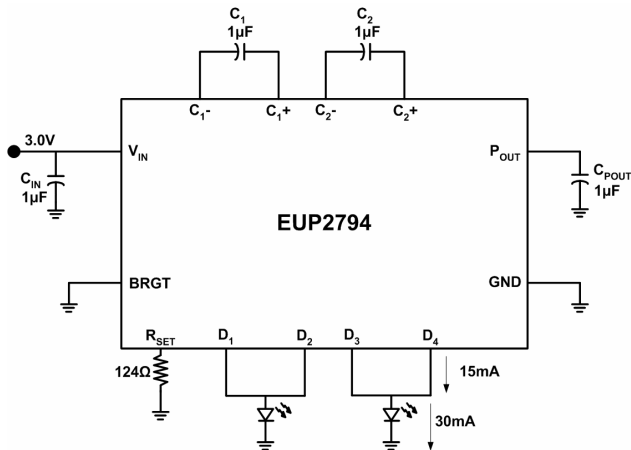

Figure 5. Two Parallel Connected LEDs

With this configuration, two parallel current sources of equal value provide current to each LED. R_{SET} and V_{BRGT} should therefore be chosen so that the current through each output is programmed to 50% of the desired current through the parallel connected LEDs. For example, if 30mA is the desired drive current for 2 parallel connected LEDs, R_{SET} and V_{BRGT} should be selected so that the current through each of the outputs is 15mA. Other combinations of parallel outputs may be implemented in similar fashions, such as in Figure 6.

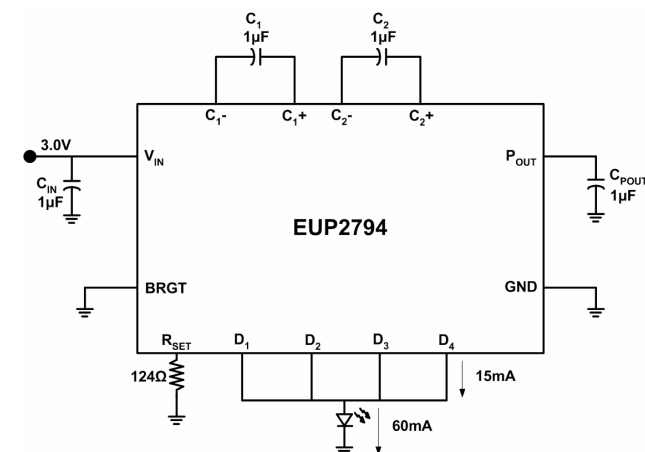

Figure 6. One Parallel Connected LED

Connecting outputs in parallel does not affect internal operation of the EUP2794 and has no impact on the Electrical Characteristics and limits previously presented. The available diode output current, maximum diode voltage, and all other specifications provided in the Electrical Characteristics table apply to parallel output configurations, just as they do to the standard 4-LED application circuit.

Thermal Protection

When the junction temperature exceeds 150°C (typ.), the EUP2794 internal thermal protection circuitry disables the part. This feature protects the device from damage due to excessive power dissipation. The device will recover and operate normally when the junction temperature falls below 140°C (typ.). It is important to have good thermal conduction with a proper layout to reduce thermal resistance.

Power Efficiency

Figure 7 shows the efficiency of the EUP2794. The change in efficiency shown by the graph comes from the transition from Pass Mode to a gain of 1.5.

Efficiency (E) of the EUP2794 is defined here as the ratio of the power consumed by LEDs (P_{LED}) to the power drawn from the input source (P_{IN}). In the equations below, I_Q is the quiescent current of the EUP2794, I_{LED} is the current flowing through one LED, V_{LED} is the forward voltage at that LED current, and N is the number of LEDs connected to the regulated current outputs. In the input power calculation, the 1.5 represents the switched capacitor gain configuration of the EUP2794.

$$P_{LED} = N \times V_{LED} \times I_{LED}$$

$$P_{IN} = V_{IN} \times I_{IN}$$

$$P_{IN} = V_{IN} \times (1.5 \times N \times I_{LED} + I_Q)$$

$$E = (P_{LED} \div P_{IN})$$

Efficiency, as defined here, is in part dependent on LED voltage. Variation in LED voltage does not affect power consumed by the circuit and typically does not relate to the brightness of the LED. For an advanced analysis, it is recommended that power consumed by the circuit (V_{IN} x I_{IN}) be evaluated rather than power efficiency. Figure 8 shows the power consumption of the EUP2794 Typical Application Circuit.

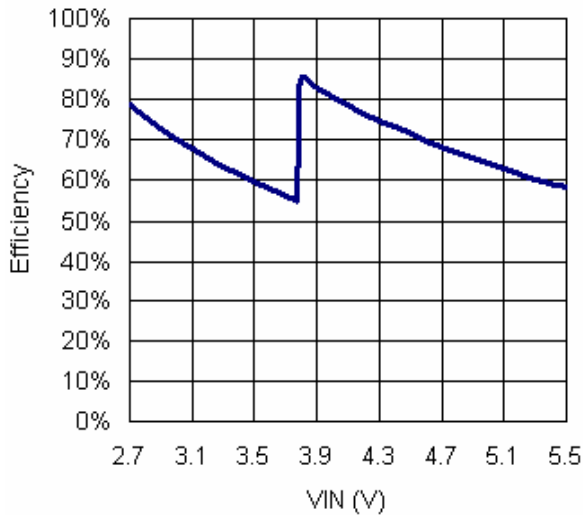

Figure 7. Efficiency vs VIN
4 LEDs, V_{LED}=3.4V, I_{LED}=15mA

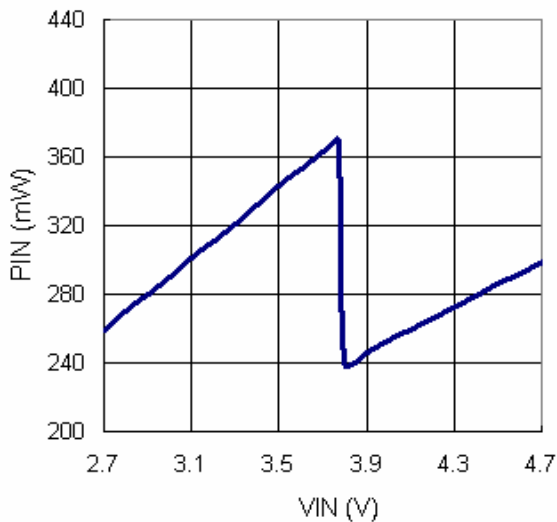

Figure 8. PIN vs VIN
4 LEDs, 2.5 ≤ V_{DX} ≤ 3.4V, I_{DX}=15mA

Power Dissipation

The power dissipation (P_{DISSIPATION}) and junction temperature (T_J) can be approximated with the equations below. P_{IN} is the power generated by the 1.5x charge pump, P_{LED} is the power consumed by the LEDs, P_{POUT} is the power provided through the P_{OUT} pin, T_A is the ambient temperature, and θ_{JA} is the junction-to-ambient thermal resistance for the QFN-16 package. V_{IN} is the input voltage to the EUP2794, V_{DX} is the LED forward voltage, I_{DX} is the programmed LED current, and I_{POUT} is the current drawn through P_{OUT}.

$$P_{DISSIPATION} = P_{IN} - P_{LED} - P_{POUT}$$

$$= [1.5 \times V_{IN} \times (4I_{DX} + I_{POUT})] - (1.5 \times V_{IN} \times I_{POUT})$$

$$T_J = T_A + (P_{DISSIPATION} \times \theta_{JA})$$

The junction temperature rating takes precedence over the ambient temperature rating. The EUP2794 may be operated outside the ambient temperature rating, so long as the junction temperature of the device does not exceed the maximum operating rating of 100°C. The maximum ambient temperature rating must be derated in applications where high power dissipation and/or poor thermal resistance causes the junction temperature to exceed 100°C.

Packaging Information

QFN-16

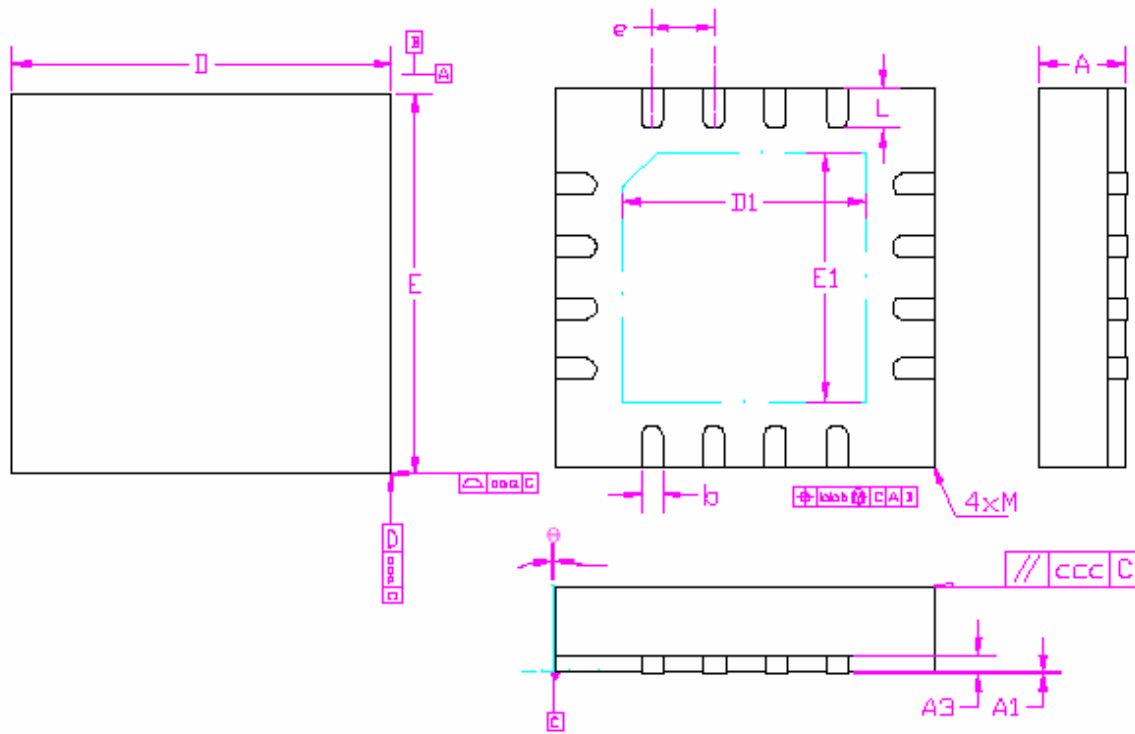

Note

1. All dimensions are in millimeters. is in Degrees.
2. M: The maximum allowable corner on the molded plastic body corners.
3. Dimension D does not include mold protrusions or gate burrs. Mold
4. Dimension E does not include interterminal mold protrusions or terminal protrusions. Interterminal mold protrusions and/or terminal protrusions shall not exceed 0.20 mm per side.
5. Dimension b applies to plated terminals. Dimension a1 is primarily Y terminal plating ,but may or may not include A small protrusion of terminal below the bottom surface of the package.

| SYMBOLS | DIMENSIONS IN MILLIMETERS | | |
|---------|---------------------------|----------|-------|
| | MIN. | NOM. | MAX. |
| A | 0.80 | 0.90 | 1.00 |
| A1 | 0 | 0.015 | 0.030 |
| A3 | ---- | 0.20REF. | ---- |
| b | 0.18 | 0.23 | 0.30 |
| D | 2.85 | 3.00BSC | 3.15 |
| D1 | ---- | 1.48 BSC | ---- |
| E | 2.85 | 3.00BSC | 3.15 |
| E1 | ---- | 1.48 BSC | ---- |
| e | ---- | 0.50BSC | ---- |
| L | 0.30 | 0.40 | 0.50 |
| | -12 | ---- | 0 |
| aaa | ---- | 0.25 | ---- |
| bbb | ---- | 0.10 | ---- |
| ccc | ---- | 0.10 | ---- |
| M | ---- | ---- | 0.05 |
| Burr | 0 | 0.030 | 0.060 |