



Precision Centigrade Temperature Sensor

FEATURES

- Linear +10.0mv/°C Scale Factor
- 0.5°C Accuracy Guaranteeable (at +25°C)
- Calibrated Directly In ° Celsius (Centigrade)
- Operates From 4V to 30V
- Less Than 60µA Current Drain
- Nonlinearity Only ±1/4°C Typical
- Low Impedance Output, 0.1 Ω For 1ma Load
- Rated For Full -55°C To +150°C Range
- Similar Replacement For LM35

PRODUCT DESCRIPTION

The ALPHA Semiconductor AS35 is a Precision Integrated-Circuit Temperature Sensor. Its output voltage is linearly proportional to Celsius (Centigrade) temperature. Trimming and calibration at the wafer level assures low cost and provides typical accuracy of ±3/4°C over a full -55°C to +150°C temperature range. Due to the AS35's low output impedance, linear output, and precise inherent calibration, interfacing to readout or control circuitry is especially easy. It can be used with single power supplies, or with plus and minus supplies.

ORDERING INFORMATION

| SOIC 8-PIN | SOT-89 | TO-92 3-PIN | TO-46 3-PIN | Oper. Temp. Range |
|---------------|---------|----------------|----------------|----------------------|
| | | | AS35T | -55°C to +150°C |
| | | | AS35AT | -55°C to +150°C |
| | | | AS35CT | -40°C to +110°C |
| AS35CS | AS35CM1 | AS35CN | AS35CAT | -40°C to +110°C |
| AS35DS | AS35DM1 | AS35DN | AS35DT | 0°C to +100°C |
| AS35FS | AS35FM1 | AS35FN | AS35FT | 0°C to +100°C |

PIN CONNECTIONS

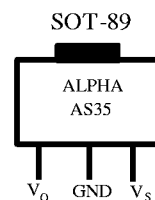

Front View

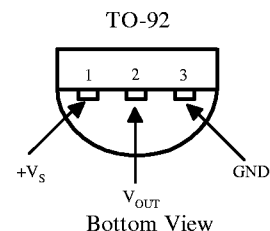
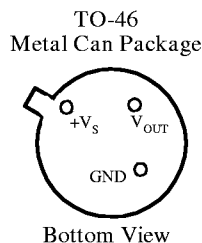
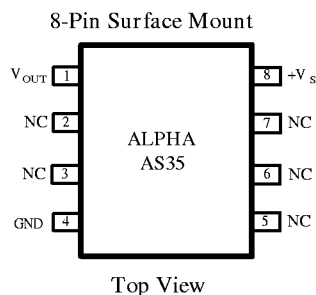

ABSOLUTE MAXIMUM RATINGS

Supply Voltage+35V to -0.2V
 Output Voltage+6V to -1.0V
 Output Current10mA
 Storage Temp., TO-46 Package-60° to +180°C
 TO-92 Package.....-60° to +150°C

Specified Operating Temperature Range: T_{min} to T_{max}
 AS35.....-55°C to +150°C
 AS35B-40°C to +110°C
 Lead Temp. (Soldering, 10 seconds):
 TO-46 Package 300°C
 TO-92 Package..... 260°C

Temperature rise of AS35 due to self-heating (Thermal Resistance)

| | To-46 No Heat Sink | TO-46 Small Heat Fin | TO-92 No Heat Sink | TO-92 No Heat Sink |
|---|-----------------------|-------------------------|-----------------------|-----------------------|
| Still air | 400°C/W | 100°C/W | 180°C/W | 140°C/W |
| Moving air | 100°C/W | 40°C/W | 90°C/W | 70°C/W |
| Still oil | 100°C/W | 40°C/W | 90°C/W | 70°C/W |
| Stirred oil | 50°C/W | 30°C/W | 45°C/W | 40°C/W |
| (Clamped to metal, infinite heat sink) | (24°C/W) | | | |

ELECTRICAL CHARACTERISTICS

(Note 1) (Note 5)

| PARAMETER | CONDITIONS | AS35 | | | AS35B | | | UNITS |
|---|---|-----------|------------|-----------|-----------|------------|-----------|--|
| | | Min | Typ | Max | Min | Typ | Max | |
| Accuracy (Note 6) | $T_a=+25^\circ\text{C}$ | ± 0.5 | ± 0.2 | ± 1.0 | ± 0.5 | ± 0.2 | ± 1.0 | $^\circ\text{C}$ |
| | $T_a=-10^\circ\text{C}$ | | ± 0.3 | | | ± 0.3 | | $^\circ\text{C}$ |
| | $T_{min} \leq T_a \leq T_{max}$ | | ± 0.8 | | | ± 0.8 | | $^\circ\text{C}$ |
| Nonlinearity (Note 7) | $T_{min} \leq T_a \leq T_{max}$ | | ± 0.18 | | | ± 0.15 | | $^\circ\text{C}$ |
| Sensor Gain (Average Slope) | $T_{min} \leq T_a \leq T_{max}$ | +9.9 | +10 | +10.1 | | +10 | | mV/ $^\circ\text{C}$ mV/ $^\circ\text{C}$ |
| Load Regulation 0<I _L <1mA (Note 3) | $T_a=+25^\circ\text{C}$ | | ± 0.4 | ± 1.0 | | ± 0.4 | ± 1.0 | mV/mA |
| | $T_{min} \leq T_a \leq T_{max}$ | | ± 0.5 | | | ± 0.5 | | A |
| Line Regulation (Note 3) | $T_a=+25^\circ\text{C}$ | | ± 0.01 | \pm | | ± 0.01 | \pm | mV/V |
| | $T_{min} \leq T_a \leq T_{max}$ | | ± 0.02 | 0.05 | | ± 0.02 | 0.05 | mV/V |
| Quiescent Current (Note 8) | $V_s=+5\text{V}, +25^\circ\text{C}$ | | 56 | 67 | | 56 | 67 | μA |
| | $V_s=+5\text{V}$ | | 105 | | | 91 | | μA |
| | $V_s=+30\text{V}, +25^\circ\text{C}$ | | 56.2 | 68 | | 56.2 | 68 | μA |
| | $V_s=+30\text{V}$ | | 105.5 | | | 91.5 | | μA |
| Change of Quiescent Current (Note 3) | $4\text{V} \leq V_s \leq 30\text{V}, +25^\circ\text{C}$ | | 0.2 | 1.0 | | 0.2 | 1.0 | μA |
| | $4\text{V} \leq V_s \leq 30\text{V}$ | | 0.5 | | | 0.5 | | μA |
| Temperature Coefficient of Quiescent Current | | | 0.39 | | | 0.39 | | $\mu\text{A}/^\circ\text{C}$ |
| Minimum Temperature for Rated Accuracy | | | +1.5 | | | +1.5 | | $^\circ\text{C}$ |
| Long Term Stability | $T_j=T_{max}$, for 1000 hours | | ± 0.08 | | | ± 0.08 | | $^\circ\text{C}$ |

ELECTRICAL CHARACTERISTICS

(NOTE 1) (NOTE 5)

| PARAMETER | CONDITIONS | AS35 | | | AS35C AS35D AS35F | | | UNITS |
|--|-------------------------|------|-------|-------|-------------------------|-------|------|-------|
| | | Min. | Typ. | Max. | Min. | Typ. | Max. | |
| Accuracy, AS35, AS35C (Note 6) | Ta=+25°C | | ±0.4 | ±1.0 | | ±0.4 | | °C |
| | Ta=-10°C | | ±0.5 | | | ±0.5 | | °C |
| | Tmin≤Ta≤Tmax | | ±0.8 | ±1.5 | | ±0.8 | ±1.0 | °C |
| Accuracy, AS35D (Note 6) | Ta=+25°C | | | | | ±0.6 | | °C |
| | Tmin≤Ta≤Tmax | | | | | ±0.9 | ±1.5 | °C |
| Accuracy, AS35F (Note 6) | Ta=+25°C | | | | | ±0.6 | | °C |
| | Tmin≤Ta≤Tmax | | | | | ±1.5 | ±3 | °C |
| Nonlinearity (Note 7) | Tmin≤Ta≤Tmax | | ±0.3 | | | ±0.2 | | °C |
| Line Regulation (Note 3) | Ta=25°C | | ±0.01 | ±0.1 | | ±0.01 | ±0.1 | mV/V |
| | 4V≤Vs≤30V | | ±0.02 | | | ±0.02 | | mV/V |
| Load Regulation 0≤IL≤1mA (Note 3) | Ta=+25°C | | ±0.4 | ±2.0 | | ±0.4 | ±2.0 | mV/mA |
| | Tmin≤Ta≤Tmax | | ±0.5 | | | ±0.5 | | mV/mA |
| Load Regulation 0≤IL≤1mA, AS35F ONLY (Note 3) | Ta=+25°C | | | | | ±0.4 | ±3.0 | mV/mA |
| | Tmin≤Ta≤Tmax | | | | | ±1.5 | | mV/mA |
| Quiescent Current (Note 8) | Vs=+5V, +25°C | | 56 | 80 | | 56 | 80 | μA |
| | Vs=+5V | | 105 | | | 91 | | μA |
| | Vs=+30V, +25°C | | 56.2 | 82 | | 56.2 | 82 | μA |
| | Vs=+30V | | 105.5 | | | 91.5 | | μA |
| Change of Quiescent Current (Note 3) | 4V≤Vs≤30V, +25°C | | 0.2 | 2.0 | | 0.2 | 2.0 | μA |
| | 4V≤Vs≤30V | | 0.5 | | | 0.5 | | μA |
| Temperature Coefficient of Quiescent Current | | | 0.39 | | | 0.39 | | μA/°C |
| Minimum Temperature for Rated Accuracy | | | +1.5 | | | +1.5 | | °C |
| Minimum Temperature for Rated Accuracy, AS35F | | | | | | +3.0 | | °C |
| Long Term Stability | Tj=Tmax, for 1000 hours | | ±0.08 | | | ±0.08 | | °C |
| Sensor Gain (Average Slope) | Tmin≤Ta≤Tmax | +9.8 | +10 | +10.2 | | +10 | | μV/°C |

Note 1: Unless otherwise noted, these specifications apply: -55°C≤Tj≤150°C for the AS35 and AS35A; -40°C≤Tj≤-110°C for the AS35C and AS35CA; 0≤Tj≤+100°C for the AS35D. Vs=+5Vdc and Iload=50mA, in the circuit of Figure 2. These specifications also apply from +2°C to Tmax in the circuit of Figure 1.

Note 2: Thermal resistance of the TO-46 package is 440°C/W, junction to ambient, and 24°C/W junction to case. Thermal resistance of the TO-92 package is 180°C/W junction to ambient.

Note 3: Regulation is measured at constant junction temperature, using pulse testing with a low duty cycle. Changes in output due to heating effects can be computed by multiplying the internal dissipation by the thermal resistance.

Note 4: Tested limits are guaranteed and 100% tested in production.

Note 5: Specifications in boldface apply over the full rated temperature range.

Note 6: Accuracy is defined as the error between the output voltage and 10mv/°C times the device's case temperature, at specified conditions of voltage, current, and temperature (expressed in °C).

Note 7: Nonlinearity is defined as the deviation of the output-voltage-versus-temperature curve from the best-fit straight line, over the device's rated temperature range.

Note 8: Quiescent current is defined in the circuit of Figure 1.

Note 9: Absolute Maximum Ratings indicate limits beyond which damage to the device may occur. DC and AC electrical specifications do not apply when operating the device beyond its rated operating conditions. See Note 1.

TYPICAL PERFORMANCE

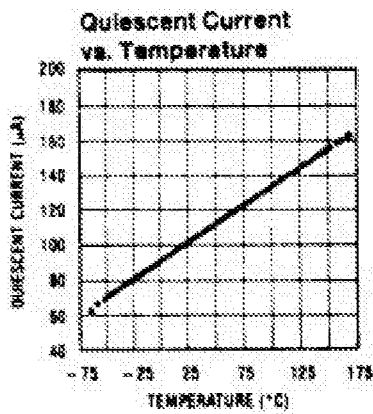
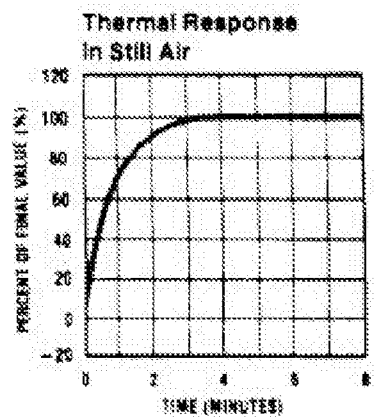
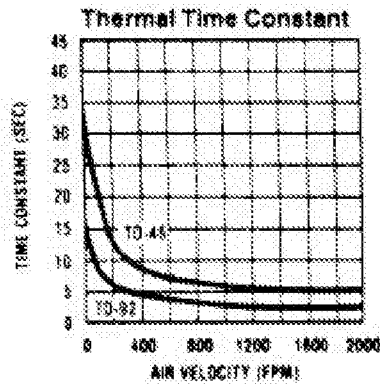
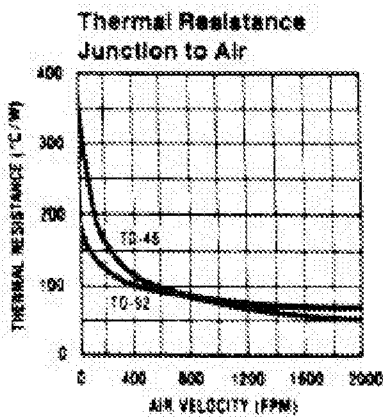
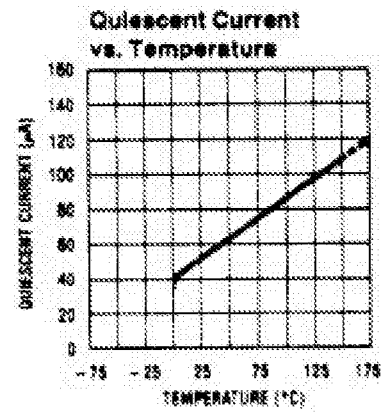
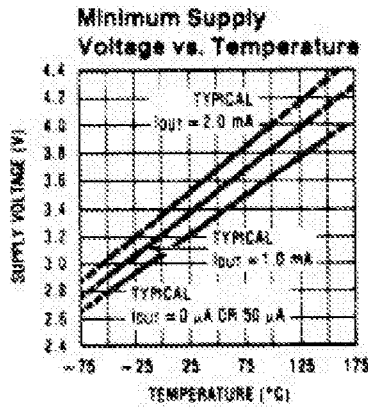
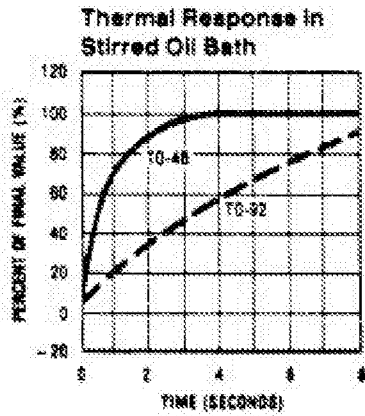

APPLICATIONS

The AS35 should be applied easily in the same way as other temperature sensors. It can be cemented or glued to a surface and its temperature will be within about 0.01 °C of the surface temperature. In the case of the temperature being higher or lower than the surface temperature, the AS35 temperature would be at an intermediate temperature between the surface and air temperature. This should be taken into consideration with the TO-92 and plastic packages especially.

If the wiring to the AS35 is held at the same temperature as the surface of interest then this can minimize the above problem. The wire should be covered with some epoxy to insure that the temperature stays the same and that the AS35's die temperature will not be affected by the air temperature. The AS35 in the TO-46 package can also be soldered to a metal surface without any damage. The negative supply needs to be grounded to the metal. This device can be mounted inside a sealed-end metal tube, and can then be dipped into a bath or screwed into a threaded hole in a tank.

The AS35 wiring should be kept insulated and dry to avoid any leakage and corrosion especially in cold temperatures where condensation can occur. Printed circuit board coatings with epoxy paints, humiseal or dips are often used to insure against moisture corrosion.

This device can also be soldered to a small heat fan to decrease the thermal time constant and speed up the response slowly-moving air.

CAPACITIVE LOADS

The AS35 is limited to a capacitive load of up to 50 pf without any precautions. The below figure will show if a heavier load is used it can be isolated or decoupled with a resistor. The tolerance of capacitance can be improved (as the below figure shows) with a series R-C damper connected from output to ground.

Other figures in this section covers different application uses of AS35.

THE TEMPERATURE RISE OF AS35 (Self heating by this device)

| | TO-92 Small Heat Sink | TO-92 Small Heat Fin | SO-8 No Heat Sink | SO-8 Small Heat Fin | TO-46 No Heat Sink | TO-46 Small Heat Fin |
|--------------------|--------------------------|-------------------------|----------------------|------------------------|-----------------------|-------------------------|
| Still air (°C/W) | 180 | 140 | 220 | 110 | 400 | 100 |
| Moving air (°C/W) | 90 | 70 | 105 | 90 | 100 | 40 |
| Still oil (°C/W) | 90 | 70 | | | 100 | 40 |
| Stirred oil (°C/W) | 45 | 40 | | | 50 | 30 |

TYPICAL APPLICATION CIRCUITS

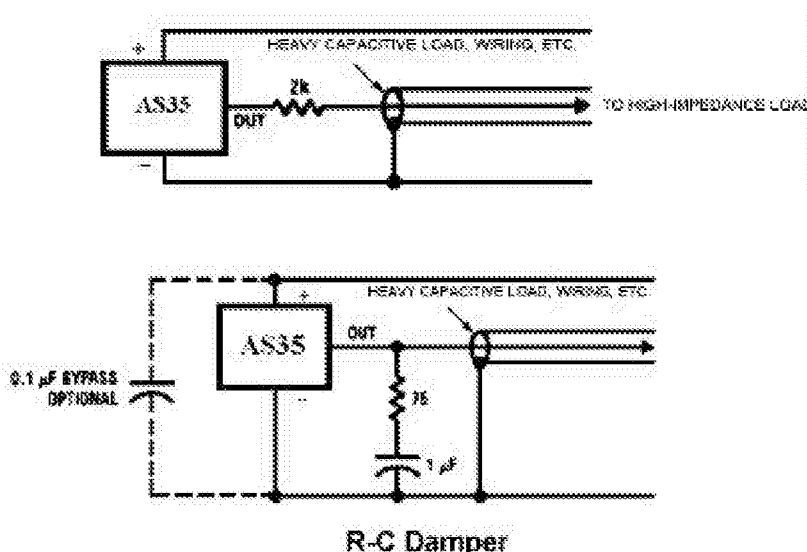

TYPICAL APPLICATION CIRCUIT

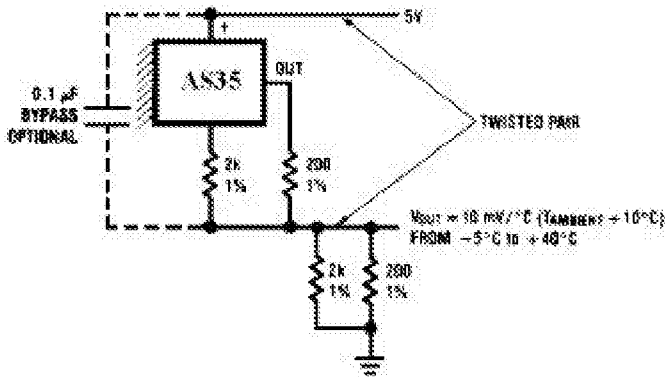

**Two-Wire Remote Temperature Sensor
(Output Referred to Ground)**

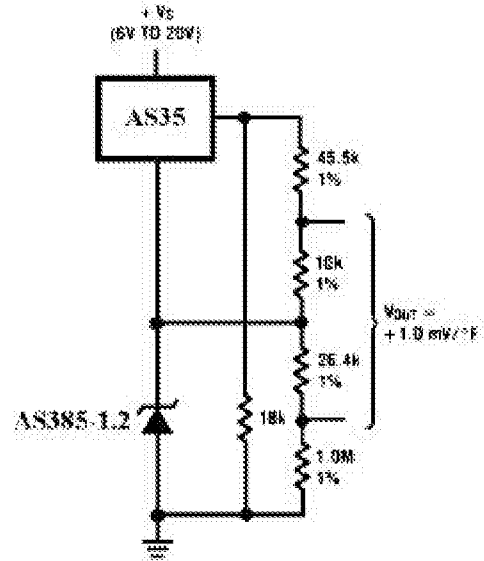

Fahrenheit Thermometer

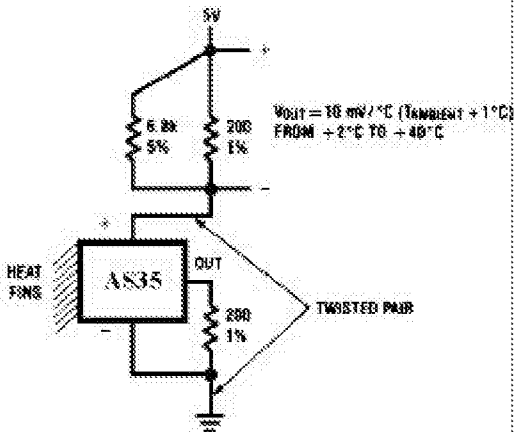

**Two-Wire Remote Temperature Sensor
(Grounded Sensor)**

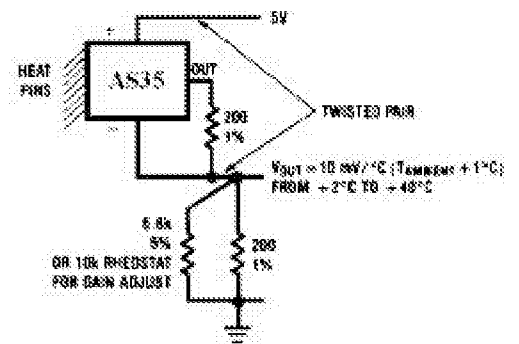

**Two-Wire Remote Temperature Sensor
(Output Referred to Ground)**

TYPICAL APPLICATION CIRCUIT

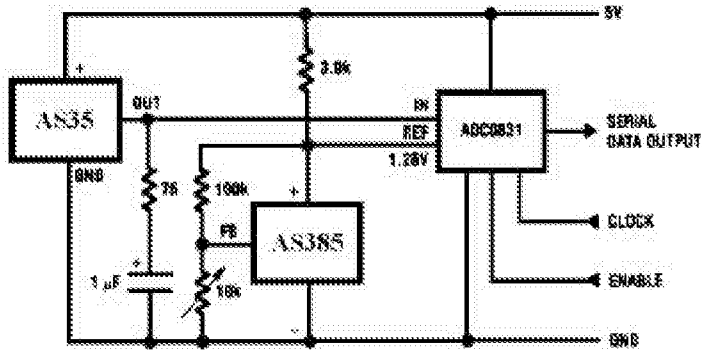

Temperature To Digital Converter (Serial Output) (+ 128°C Full Scale)

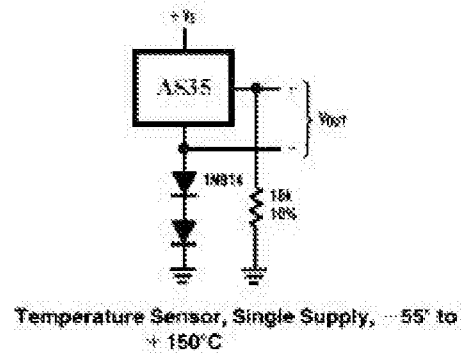

Temperature Sensor, Single Supply, -55° to + 150°C

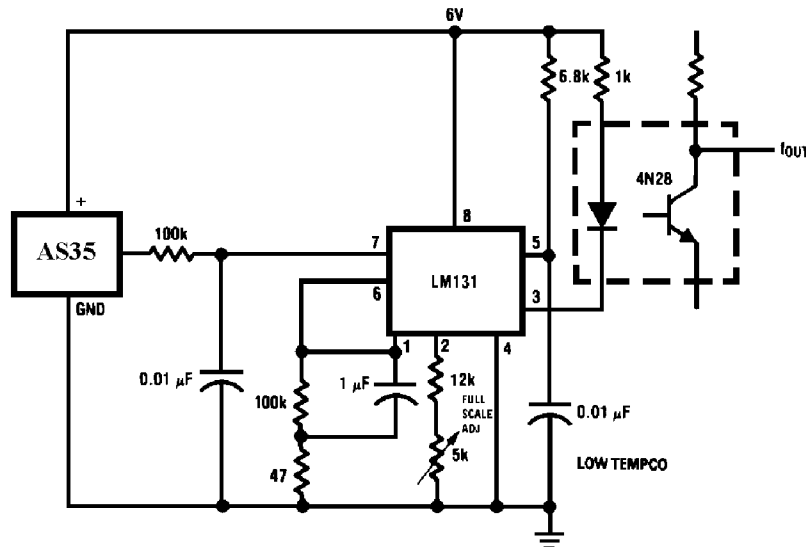

Voltage-To-Frequency Converter And Isolated Output (2°C to + 150°C; 20 Hz to 1500 Hz)