

REFLECTIVE SWITCH

T-41-73

MTRS9070, MTRS9070(LB) INFRARED LED+ PHOTO DARLINGTON

APPLICATIONS

- SENSOR FOR AUDIO, VIDEO, FILM AND DISCS

FEATURES

- Detects start/finish/location on reel for audio and VCR tapes.
- Index for floppy disc drives.
- Detects "write protect" on floppy disc (also disc in drive).
- Detects optically encoded information on film.
- Super-miniature package (2.6x3.4x1.5mm).
- High sensitivity: I_C=3mA typ.

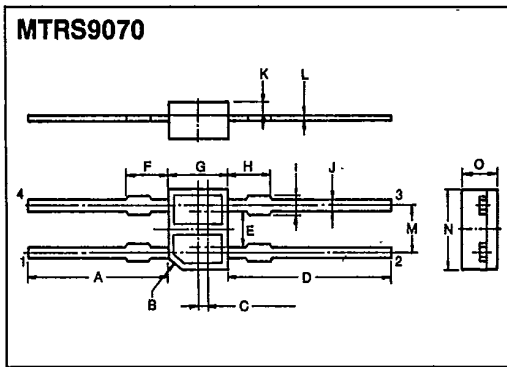

SYMBOL	INCHES	MM
A	0.276 ± 0.020	7.0 ± 0.5
B	0.002	0.05
C	0.018	0.45
D	0.276 ± 0.020	7.0 ± 0.5
E	0.063	1.6
F	0.071 ± 0.008	1.8 ± 0.2
G	0.102 ± 0.008	2.6 ± 0.2
H	0.071 ± 0.008	1.8 ± 0.2
I	0.028 ± 0.008	0.7 ± 0.2
J	0.020 ± 0.008	0.5 ± 0.2
K	0.020 ± 0.004	0.5 ± 0.1
L	0.008 ± 0.002	0.2 ± 0.05
M	0.079	2.0
N	0.134 ± 0.008	3.4 ± 0.2
O	0.059 ± 0.008	1.5 ± 0.2

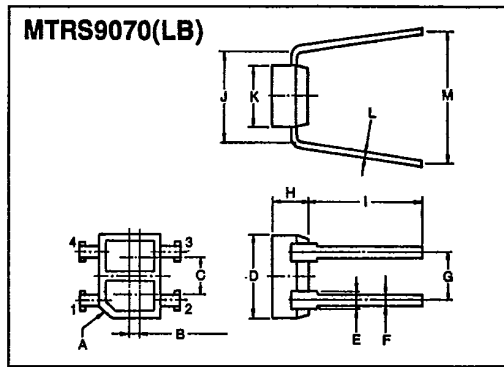

SYMBOL	INCHES	MM
A	0.020	0.5
B	0.018	0.45
C	0.063	1.6
D	0.134 ± 0.020	3.4 ± 0.5
E	0.028 ± 0.008	0.7 ± 0.2
F	0.157 ± 0.010	4.0 ± 0.25
G	0.079	2.0
H	0.059 ± 0.008	1.5 ± 0.2
I	0.220 ± 0.024	5.6 ± 0.6
J	0.157 ± 0.010	4.0 ± 0.25
K	0.102 ± 0.020	2.6 ± 0.5
L	0.008 ± 0.002	0.2 ± 0.05
M	0.148 ~ 0.287	3.75 ~ 7.3

REFLECTIVE SWITCH

T-41-73

MAXIMUM RATINGS (Ta = 25°C)

	CHARACTERISTIC	SYMBOL	RATING	UNIT
A	Forward Current	I_F	50	mA
	Pulse Forward Current (Note 1)	I_{FP}	400	mA
	Reverse Voltage	V_R	5	V
B	Collector-Emitter Voltage	V_{CEO}	30	V
	Emitter-Collector Voltage	V_{ECO}	5	V
	Collector Power Dissipation	P_C	50	mW
	Collector Current	I_C	20	mA
	Operating Temperature Range	T_{opr}	-20 ~ 85	°C
	Storage Temperature Range	T_{stg}	-30 ~ 100	°C

Note 1: Pulse width 100µsec; 100Hz

OPTO-ELECTRICAL CHARACTERISTICS (Ta = 25°C)

	CHARACTERISTIC	SYMBOL	TEST CONDITION	MIN.	TYP.	MAX.	UNIT
A	Forward Voltage	V_F	$I_F = 10\text{mA}$	1.00	1.15	1.30	V
	Reverse Current	I_R	$V_R = 5\text{V}$	—	—	10	µA
	Terminal Between Capacitance	C_T	$V=0, f=1\text{MHz}$	—	30	—	pF
B	Collector Dark Current	$I_D(I_{CEO})$	$V_{CE} = 15\text{V}, I_F = 0$	—	—	0.25	µA
	Terminal Between Capacitance	C_T	$V=0, F=1\text{MHz}$	—	7	—	pF
	Collector Current	I_C	$V_{CE} = 2\text{V}, I_F = 4\text{mA}$	0.5	3	15	mA
C	Leakage Current	I_{LEAK}	$V_{CE} = 2\text{V}, I_F = 4\text{mA}$	—	—	0.25	µA
	Collector-Emitter Saturation	$V_{CE(sat)}$	$I_F = 4\text{mA}, I_C = 0.25\text{mA}$	—	0.85	1.2	V
	Rise Time	t_r	$V_{CC} = 5\text{V}, I_C = 10\text{mA}$	—	100	—	µs
	Fall Time	t_f	$R_L = 100\Omega$	—	100	—	µs

A - EMITTER B - DETECTOR C - COUPLED

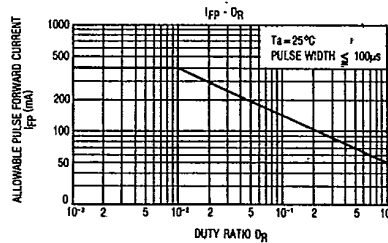
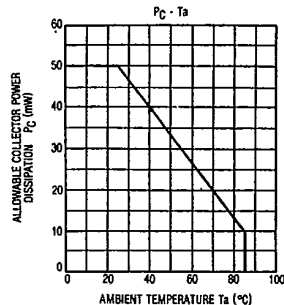
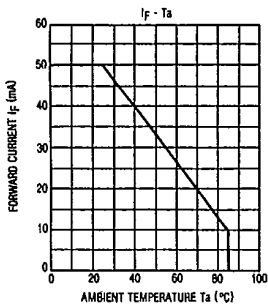
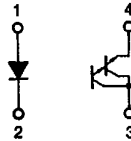
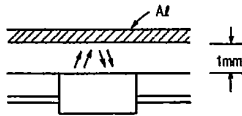

REFLECTIVE SWITCH

T-41-73

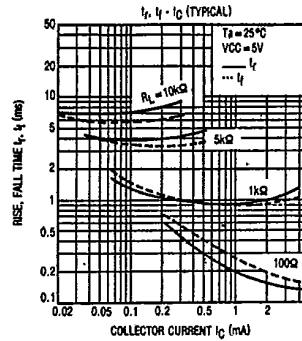
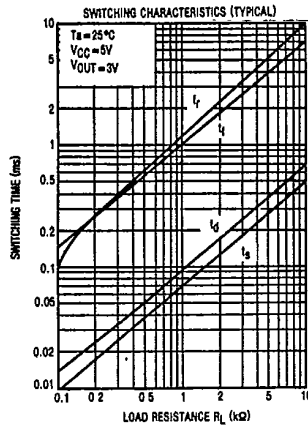
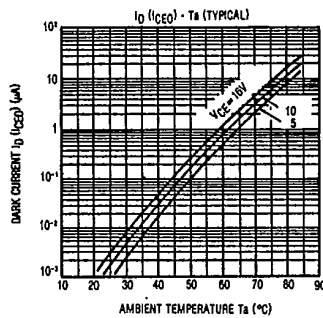
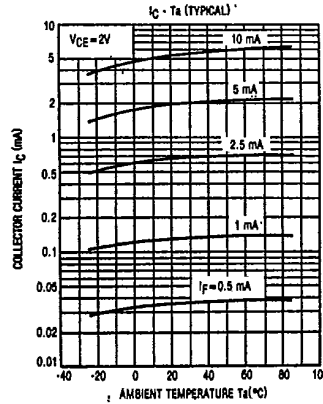
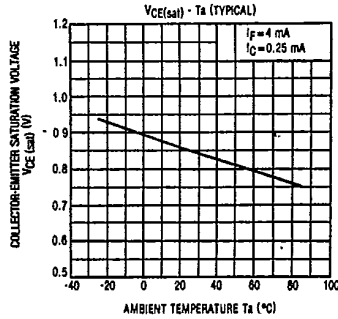
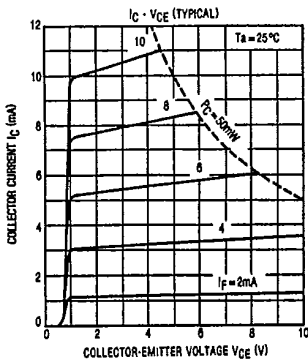
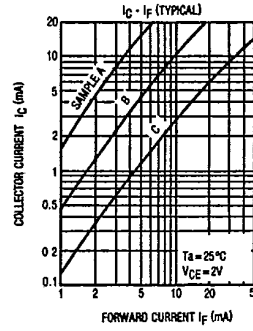
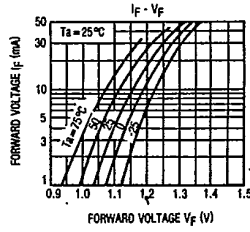
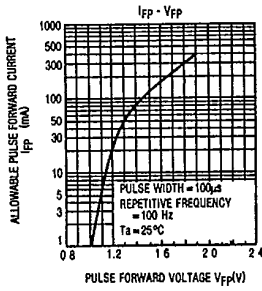

REFLECTIVE SWITCH

T-41-73

