

## 800-1000 MHz High Linearity SiGe Active Transmit Mixer

### Description

The T0785 is a high linearity active mixer which is manufactured using Atmel Wireless & Microcontrollers' advanced Silicon-Germanium technology. This mixer features a frequency range of 800 to 1000 MHz. It operates from a single 5 V supply and provides 7.5 dB of conversion gain while requiring only 0 dBm input to the integrated LO driver. An IF amplifier is also included.

The T0785 incorporates internal matching on each RF, IF and LO port to enhance ease of use and to reduce the external components required. The IF and LO inputs can be driven differentially or single ended.

Electrostatic sensitive device.  
Observe precautions for handling.



### Features

- Active mixer with conversion gain
- No necessary external LO driver
- Low LO drive level required
- IF and LO ports may be driven single-ended
- Single 5 V supply voltage
- Broadband resistive 50 Ω impedances on all three ports

### Applications

- Digital communication systems
- 800-1000 MHz transceivers for base stations

### Block Diagram

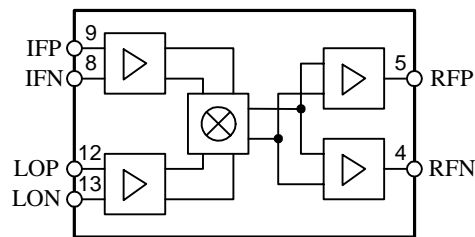

### Ordering Information

Extended Type Number	Package	Remarks
T0785	SSOP16	

## Pin Description

Pin	Symbol	Function
1	GND	Ground
2	VCC	5 V power supply
3	GND	Ground
4	RFN	RF negative output
5	RFP	RF positive output
6	GND	Ground
7	VCC	5 V power supply
8	IFN	IF negative input
9	IFP	IF positive input
10	VCC	5 V power supply
11	GND	Ground
12	LOP	Local oscillator, positive input
13	LON	Local oscillator, negative input
14	GND	Ground
15	VCC	5 V power supply
16	GND	Ground

## Pinning

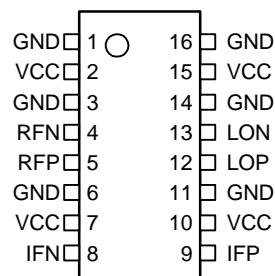

## Absolute Maximum Ratings

All voltages are referred to GND.

Parameters	Symbol	Min.	Typ.	Max.	Unit
Supply voltage	V <sub>CC</sub>		5.0	6.0	V
LO input	LON, LOP			10	dBm
IF input	IFN, IFP			15	dBm
Operating temperature	T <sub>OP</sub>	-40		+85	°C
Storage temperature	T <sub>stg</sub>	-65		+150	°C

## Thermal Resistance

Parameters	Symbol	Value	Unit
Junction ambient	R <sub>thJA</sub>	t.b.d.	K/W

## Electrical Characteristics

Test conditions:  $V_{CC} = +5\text{ V}$ ,  $T_{amb} = +25^{\circ}\text{C}$

IF input:  $-20\text{ dBm}$  @ 200 MHz

LO input:  $0\text{ dBm}$  @ 740 MHz

Parameters	Test Conditions / Pins	Symbol	Min.	Typ.	Max.	Unit
<b>AC Performance</b>						
Frequency range		f	800		1000	MHz
IF frequency range		$f_{IF}$	10	200	300	MHz
Output IP3	IF1 = IF2 = $-20\text{ dBm}$ /tone	IP3		17		dBm
Output P1dB				2		dBm
Conversion gain				7.5		dB
SSB noise figure				10		dB
RF return loss				14		dB
LO return loss				14		dB
IF return loss				14		dB
LO drive			-3	0	3	dBm
<b>Isolation performance</b>						
Leakage (LO-RF)				-35		dBm
Leakage (LO-IF)				-30		dBm
<b>Miscellaneous</b>						
Supply voltage		$V_{CC}$	4.75	5	5.25	V
Supply current		$I_{CC}$		190		mA

## Typical Device Performance

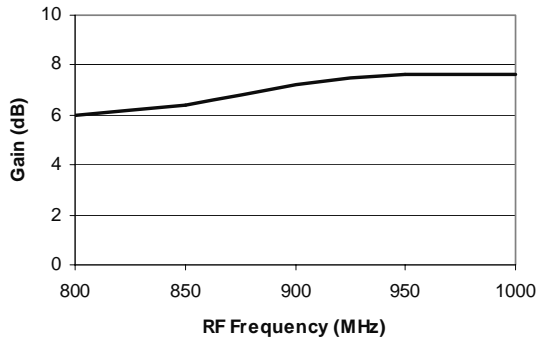

Figure 1. Conversion Gain  
 $V_{CC} = 5.0\text{ V}$ , RF = 940 MHz, IF = 200 MHz

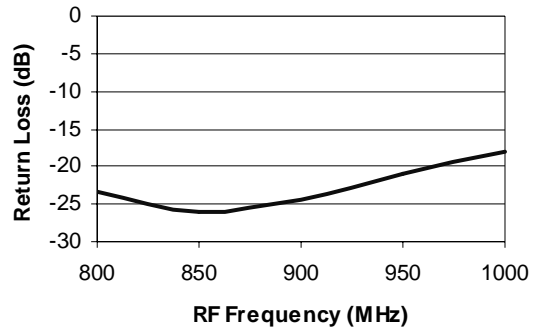

Figure 2. Return Loss at RF Input  
 $V_{CC} = 5.0\text{ V}$

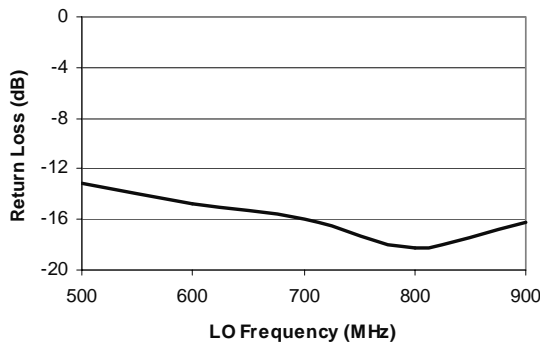

Figure 3. Return Loss at LO Input  
 $V_{CC} = 5.0\text{ V}$

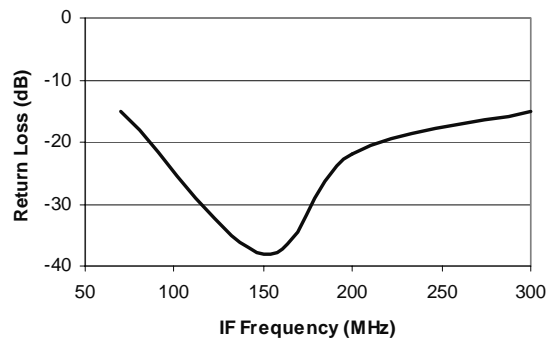
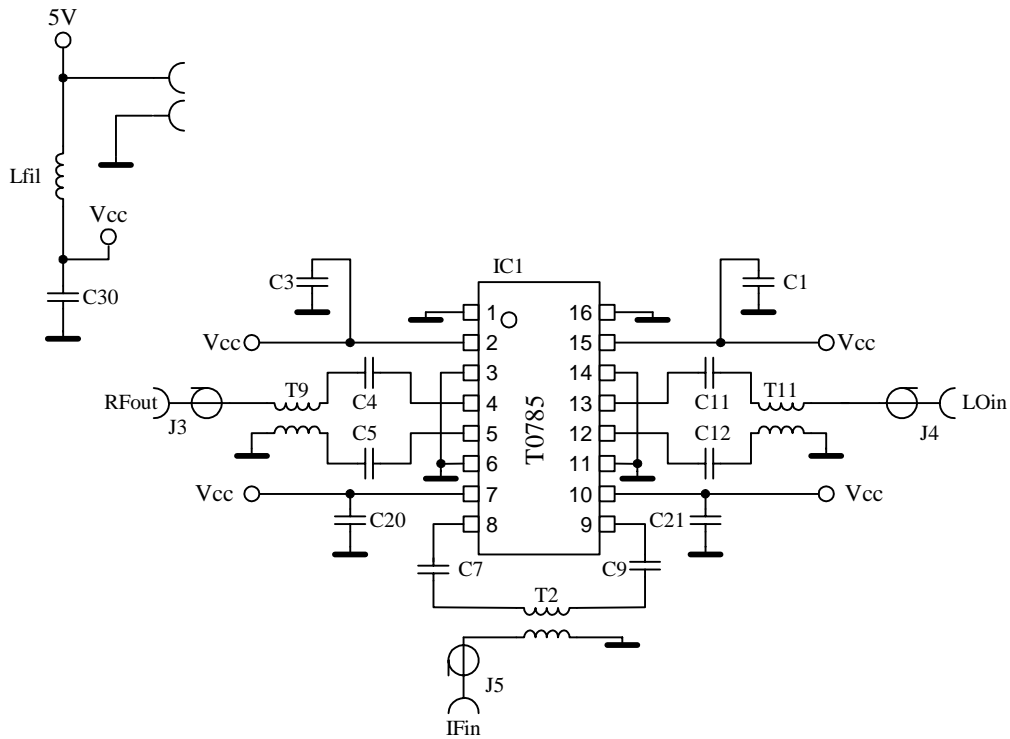

Figure 4. Return Loss at IF Input  
 $V_{CC} = 5.0\text{ V}$

## Demo Test Board Schematic



## Bill of Material

Component Designator	Value	Vendor	Part Number	Description
IC1		Atmel Wireless & Microcontrollers	T0785	SiGe transmit mixer
J3, J4, J5		Johnson Components	142-0701-851	SMA connector, end launch with tab, for .062 inch thick board
T9, T11	1:1	Panasonic	EHF-FD1618	RF transformer
T2	1:1	Mini-Circuits	TC1-1	IF transformer
Lfil	1 μH			Inductor, 1210 footprint, min. 200 mA rating
C1, C3, C20, C21, C30	27 pF			Capacitor, 0603 footprint
C7, C9	100 pF			Capacitor, 0603 footprint
C4, C5	12 pF			Capacitor, 0603 footprint
C11, C12	18 pF			Capacitor, 0603 footprint

## Demo Test Board (Fully Assembled PCB)

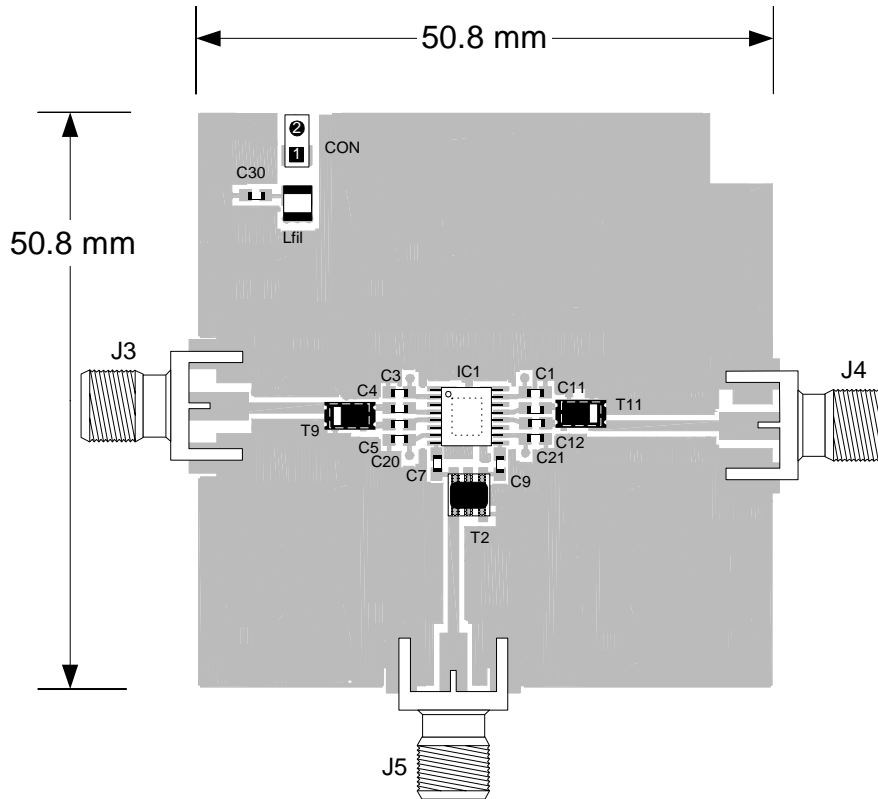

## Recommended Package Footprint

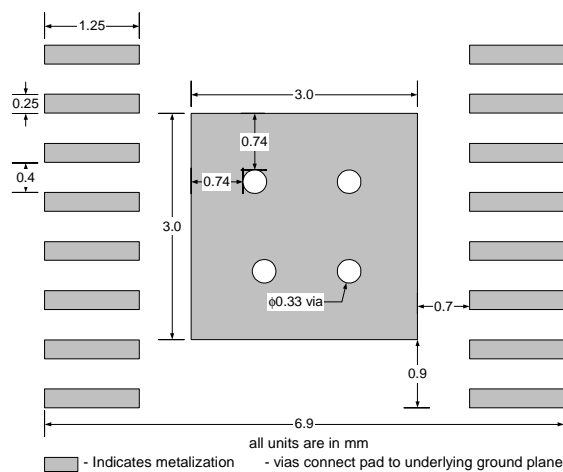

Remark: Heatslug must be soldered to GND

## Package Information SSOP16

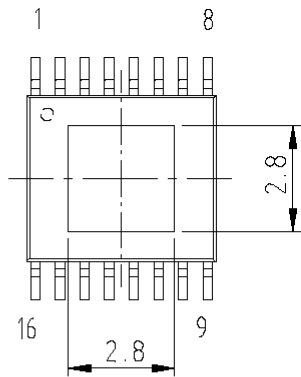

Package: SSOP16  
 ( acc. JEDEC SMALL OUTLINE No. MO-153 )  
 Dimensions in mm

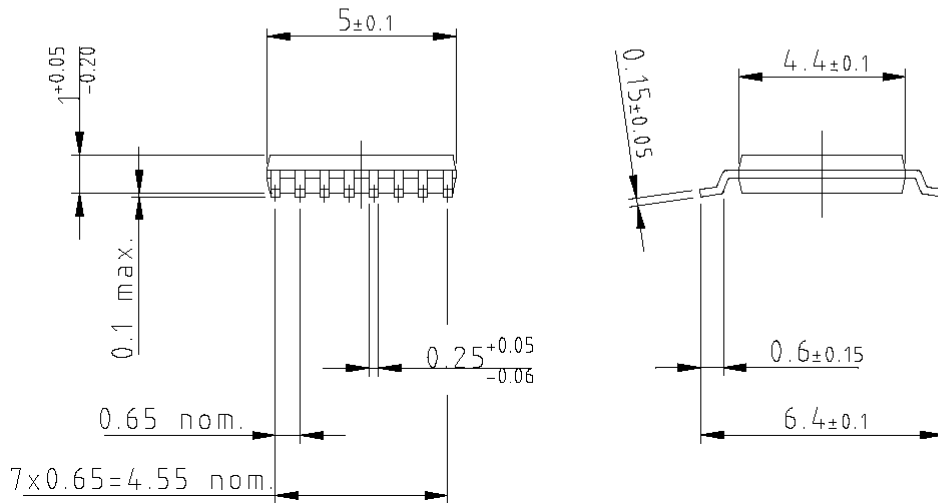
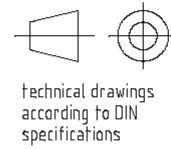

## Ozone Depleting Substances Policy Statement

It is the policy of **Atmel Germany GmbH** to

1. Meet all present and future national and international statutory requirements.
2. Regularly and continuously improve the performance of our products, processes, distribution and operating systems with respect to their impact on the health and safety of our employees and the public, as well as their impact on the environment.

It is particular concern to control or eliminate releases of those substances into the atmosphere which are known as ozone depleting substances (ODSs).

The Montreal Protocol (1987) and its London Amendments (1990) intend to severely restrict the use of ODSs and forbid their use within the next ten years. Various national and international initiatives are pressing for an earlier ban on these substances.

**Atmel Germany GmbH** has been able to use its policy of continuous improvements to eliminate the use of ODSs listed in the following documents.

1. Annex A, B and list of transitional substances of the Montreal Protocol and the London Amendments respectively
2. Class 1 and 11 ozone depleting substances in the Clean Air Act Amendments of 1990 by the Environmental Protection Agency (EPA) in the USA
3. Council Decision 88/540/EEC and 91/690/EEC Annex A, B and C (transitional substances) respectively.

**Atmel Germany GmbH** can certify that our semiconductors are not manufactured with ozone depleting substances and do not contain such substances.

**We reserve the right to make changes to improve technical design and may do so without further notice.**

Parameters can vary in different applications. All operating parameters must be validated for each customer application by the customer. Should the buyer use Atmel Wireless & Microcontrollers products for any unintended or unauthorized application, the buyer shall indemnify Atmel Wireless & Microcontrollers against all claims, costs, damages, and expenses, arising out of, directly or indirectly, any claim of personal damage, injury or death associated with such unintended or unauthorized use.

**Data sheets can also be retrieved from the Internet: <http://www.atmel-wm.com>**

Atmel Germany GmbH, P.O.B. 3535, D-74025 Heilbronn, Germany  
Telephone: 49 (0)7131 67 2594, Fax number: 49 (0)7131 67 2423