



# STE30NK90Z

## N-CHANNEL 900V - 0.21Ω - 28A ISOTOP Zener-Protected SuperMESH™ MOSFET

**Table 1: General Features**

TYPE	V <sub>DSS</sub>	R <sub>DS(on)</sub>	I <sub>D</sub>	P <sub>w</sub>
STE30NK90Z	900 V	< 0.26 Ω	28 A	500 W

- TYPICAL R<sub>DS(on)</sub> = 0.21 Ω
- EXTREMELY HIGH dv/dt CAPABILITY
- 100% AVALANCHE TESTED
- GATE CHARGE MINIMIZED

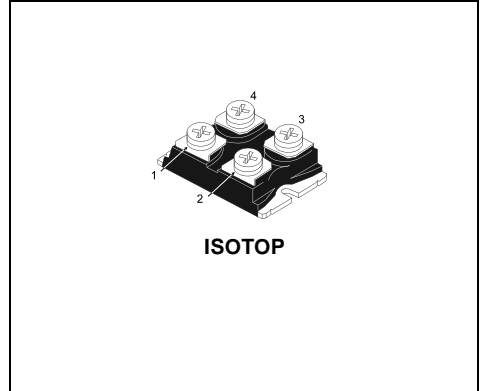
### DESCRIPTION

The SuperMESH™ series is obtained through an extreme optimization of ST's well established strip-based PowerMESH™ layout. In addition to pushing on-resistance significantly down, special care is taken to ensure a very good dv/dt capability for the most demanding applications. Such series complements ST full range of high voltage MOSFETs including revolutionary MDmesh™ products.

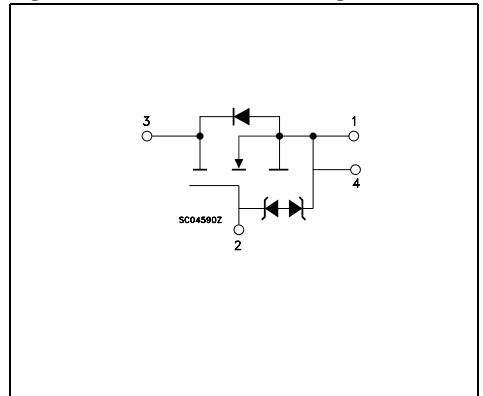
### APPLICATIONS

- HIGH CURRENT, HIGH SPEED SWITCHING
- IDEAL FOR WELDING EQUIPMENT

**Figure 1: Package**



**Figure 2: Internal Schematic Diagram**



**Table 2: Order Codes**

SALES TYPE	MARKING	PACKAGE	PACKAGING
STE30NK90Z	E30NK90Z	ISOTOP	TUBE

**Table 3: Absolute Maximum ratings**

Symbol	Parameter	Value	Unit
V <sub>DS</sub>	Drain-source Voltage (V <sub>GS</sub> = 0)	900	V
V <sub>DGR</sub>	Drain-gate Voltage (R <sub>GS</sub> = 20 kΩ)	900	V
V <sub>GS</sub>	Gate- source Voltage	± 30	V
I <sub>D</sub>	Drain Current (continuous) at T <sub>C</sub> = 25°C	28	A
I <sub>D</sub>	Drain Current (continuous) at T <sub>C</sub> = 100°C	18	A
I <sub>DM</sub> (*)	Drain Current (pulsed)	112	A
P <sub>TOT</sub>	Total Dissipation at T <sub>C</sub> = 25°C	500	W
	Derating Factor	4.3	W/°C
V <sub>ESD(G-S)</sub>	Gate source ESD(HBM-C=100pF, R=1.5KΩ)	6.5	KV
dv/dt (1)	Peak Diode Recovery voltage slope	4.5	V/ns
V <sub>ISO</sub>	Insulation Withstand Voltage (AC-RMS) from All Four Terminals to External Heatsink	2500	V
T <sub>j</sub> T <sub>stg</sub>	Operating Junction Temperature Storage Temperature	- 65 to 150	°C

(\*) Pulse width limited by safe operating area  
 (1) I<sub>SD</sub> ≤ 28A, di/dt ≤ 200 A/μs, V<sub>DD</sub> ≤ V<sub>(BR)DSS</sub>.

**Table 4: Thermal Data**

R <sub>thj-case</sub>	Thermal Resistance Junction-case Max	0.23	°C/W
R <sub>thj-amb</sub>	Thermal Resistance Junction-ambient Max	40	°C/W

**Table 5: Avalanche Characteristics**

Symbol	Parameter	Max Value	Unit
I <sub>AR</sub>	Avalanche Current, Repetitive or Not-Repetitive (pulse width limited by T <sub>j</sub> max)	13	A
E <sub>AS</sub>	Single Pulse Avalanche Energy (starting T <sub>j</sub> = 25 °C, I <sub>D</sub> = I <sub>AR</sub> , V <sub>DD</sub> = 35 V)	500	mJ

**Table 6: GATE-SOURCE ZENER DIODE**

Symbol	Parameter	Test Conditions	Min.	Typ.	Max.	Unit
BV <sub>GSO</sub>	Gate-Source Breakdown Voltage	I <sub>gs</sub> =± 1mA (Open Drain)	30			V

**PROTECTION FEATURES OF GATE-TO-SOURCE ZENER DIODES**

The built-in back-to-back Zener diodes have specifically been designed to enhance not only the device's ESD capability, but also to make them safely absorb possible voltage transients that may occasionally be applied from gate to source. In this respect the Zener voltage is appropriate to achieve an efficient and cost-effective intervention to protect the device's integrity. These integrated Zener diodes thus avoid the usage of external components.

**ELECTRICAL CHARACTERISTICS** ( $T_{CASE} = 25^{\circ}C$  UNLESS OTHERWISE SPECIFIED)**Table 7: On/Off**

Symbol	Parameter	Test Conditions	Min.	Typ.	Max.	Unit
$V_{(BR)DSS}$	Drain-source Breakdown Voltage	$I_D = 1 \text{ mA}, V_{GS} = 0$	900			V
$I_{DSS}$	Zero Gate Voltage Drain Current ( $V_{GS} = 0$ )	$V_{DS} = \text{Max Rating}$ $V_{DS} = \text{Max Rating}, T_C = 125^{\circ}C$			10 100	$\mu\text{A}$ $\mu\text{A}$
$I_{GSS}$	Gate-body Leakage Current ( $V_{DS} = 0$ )	$V_{GS} = \pm 20\text{V}$			$\pm 100$	$\mu\text{A}$
$V_{GS(th)}$	Gate Threshold Voltage	$V_{DS} = V_{GS}, I_D = 150 \mu\text{A}$	3	3.75	4.5	V
$R_{DS(on)}$	Static Drain-source On Resistance	$V_{GS} = 10\text{V}, I_D = 14 \text{ A}$		0.21	0.26	$\Omega$

**Table 8: Dynamic**

Symbol	Parameter	Test Conditions	Min.	Typ.	Max.	Unit
$g_{fs} (1)$	Forward Transconductance	$V_{DS} = 15 \text{ V}, I_D = 14 \text{ A}$		26		S
$C_{iss}$ $C_{oss}$ $C_{rss}$	Input Capacitance Output Capacitance Reverse Transfer Capacitance	$V_{DS} = 25\text{V}, f = 1 \text{ MHz}, V_{GS} = 0$		12000 852 166		pF pF pF
$C_{oss \text{ eq.}} (3)$	Equivalent Output Capacitance	$V_{GS} = 0\text{V}, V_{DS} = 0\text{V to } 720 \text{ V}$		377		pF
$t_{d(on)}$ $t_r$ $t_{d(off)}$ $t_f$	Turn-on Delay Time Rise Time Turn-off Delay Time Fall Time	$V_{DD} = 450 \text{ V}, I_D = 13 \text{ A}$ $R_G = 4.7\Omega, V_{GS} = 10 \text{ V}$ (see Figure 17)		67 59 250 72		ns ns ns ns
$Q_g$ $Q_{gs}$ $Q_{gd}$	Total Gate Charge Gate-Source Charge Gate-Drain Charge	$V_{DD} = 720 \text{ V}, I_D = 26 \text{ A},$ $V_{GS} = 10\text{V}$ (see Figure 20)		350 51 190	490	nC nC nC

**Table 9: Source Drain Diode**

Symbol	Parameter	Test Conditions	Min.	Typ.	Max.	Unit
$I_{SD}$ $I_{SDM} (2)$	Source-drain Current Source-drain Current (pulsed)				28 112	A A
$V_{SD} (1)$	Forward On Voltage	$I_{SD} = 28 \text{ A}, V_{GS} = 0$			2	V
$t_{rr}$ $Q_{rr}$ $I_{RRM}$	Reverse Recovery Time Reverse Recovery Charge Reverse Recovery Current	$I_{SD} = 26 \text{ A}, di/dt = 100 \text{ A}/\mu\text{s}$ $V_{DD} = 100 \text{ V}, T_j = 25^{\circ}C$ (see Figure 18)		1 18.9 36.6		$\mu\text{s}$ $\mu\text{C}$ A
$t_{rr}$ $Q_{rr}$ $I_{RRM}$	Reverse Recovery Time Reverse Recovery Charge Reverse Recovery Current	$I_{SD} = 26 \text{ A}, di/dt = 100 \text{ A}/\mu\text{s}$ $V_{DD} = 100 \text{ V}, T_j = 150^{\circ}C$ (see Figure 18)		1.33 25.2 37.8		$\mu\text{s}$ $\mu\text{C}$ A

Note: 1. Pulsed: Pulse duration = 300  $\mu\text{s}$ , duty cycle 1.5 %.

2. Pulse width limited by safe operating area.

3.  $C_{oss \text{ eq.}}$  is defined as a constant equivalent capacitance giving the same charging time as  $C_{oss}$  when  $V_{DS}$  increases from 0 to 80%  $V_{DSS}$ .

Figure 3: Safe Operating Area

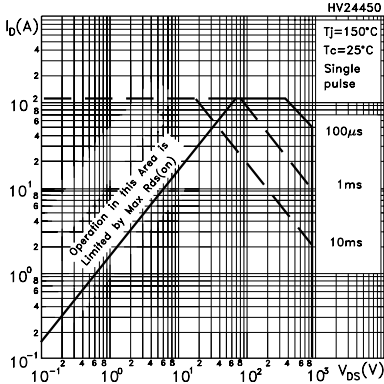


Figure 4: Output Characteristics

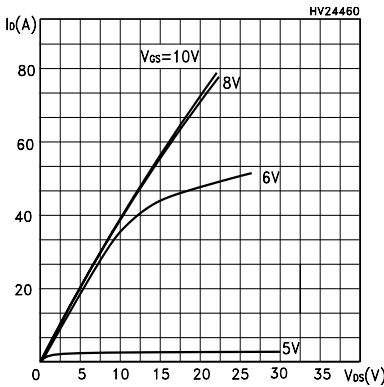


Figure 5: Transconductance

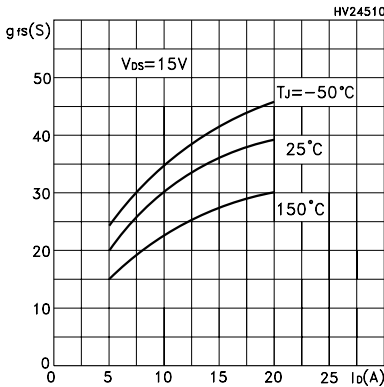


Figure 6: Thermal Impedance

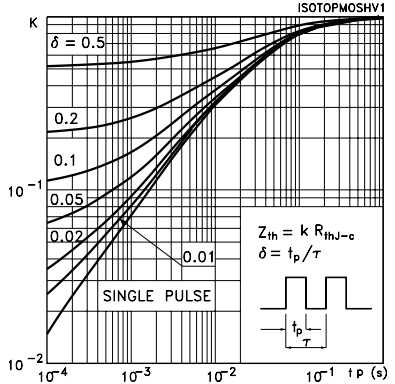


Figure 7: Transfer Characteristics

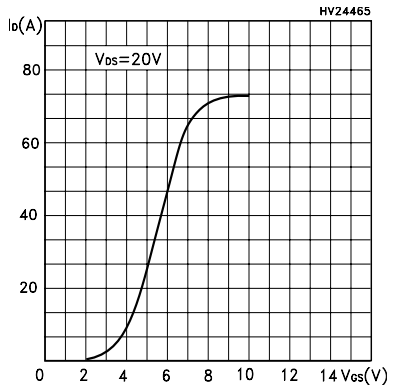


Figure 8: Static Drain-source On Resistance

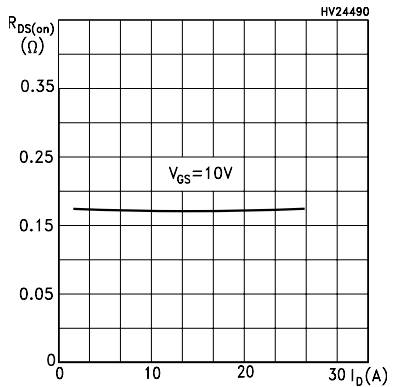


Figure 9: Gate Charge vs Gate-source Voltage

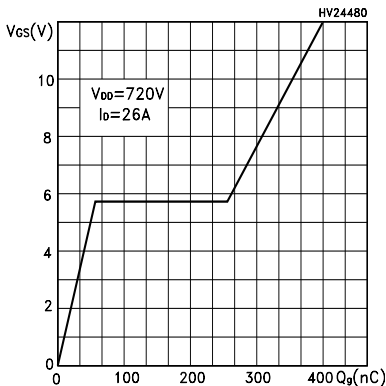


Figure 10: Normalized Gate Threshold Voltage vs Temperature

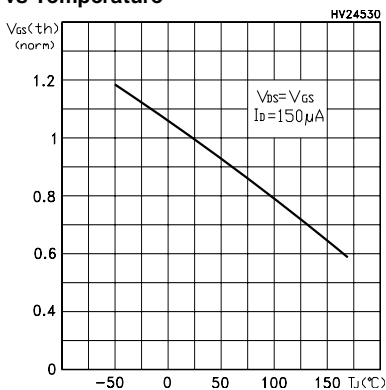


Figure 11: Source-Drain Diode Forward Characteristics

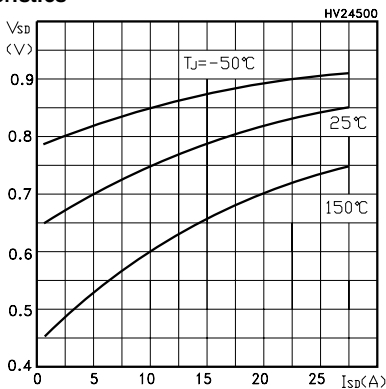


Figure 12: Capacitance Variations

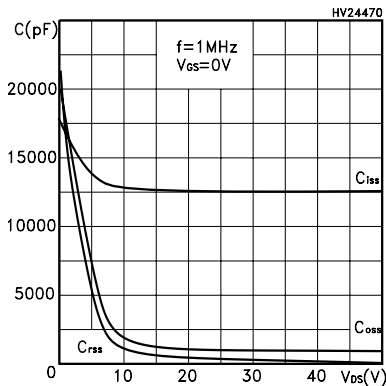


Figure 13: Normalized On Resistance vs Temperature

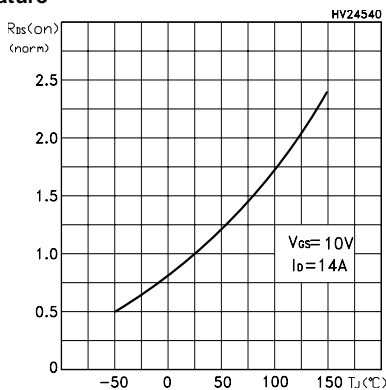


Figure 14: Normalized BVdss vs Temperature

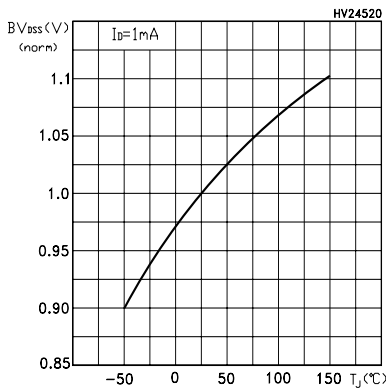
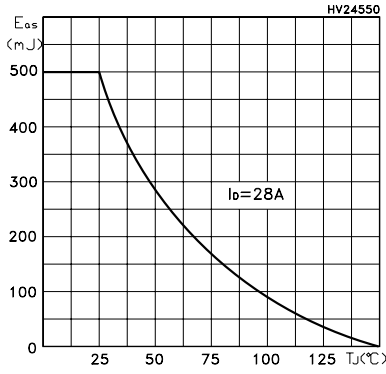
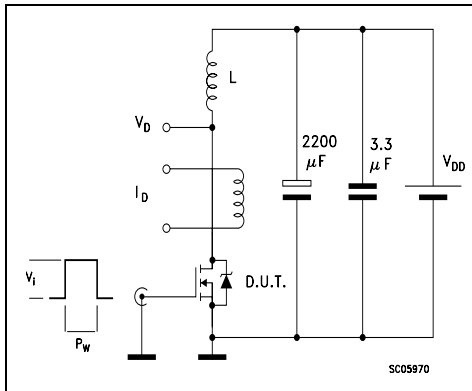


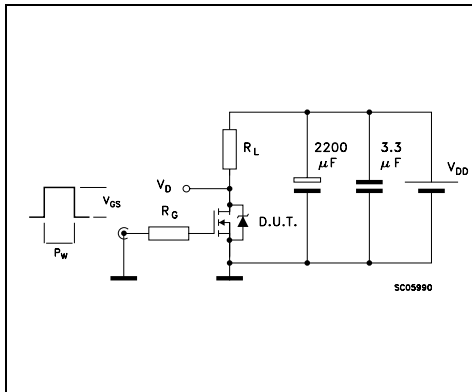
Figure 15: Avalanche Energy vs Starting Tj



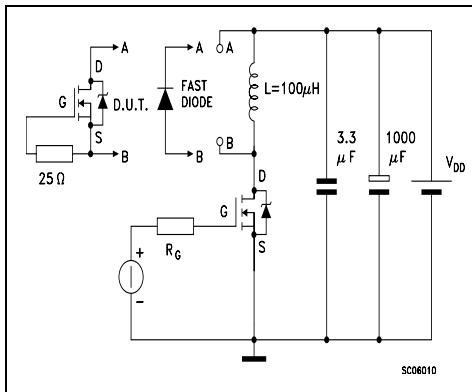
**Figure 16: Unclamped Inductive Load Test Circuit**



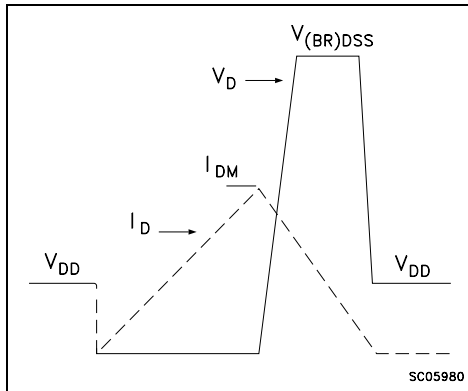
**Figure 17: Switching Times Test Circuit For Resistive Load**



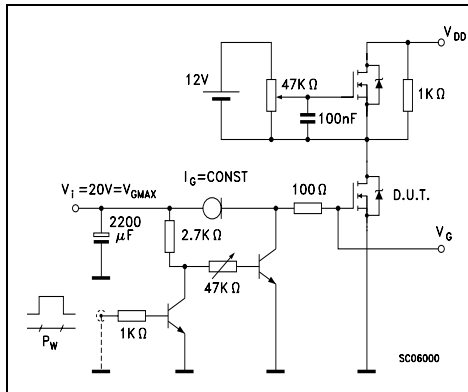
**Figure 18: Test Circuit For Inductive Load Switching and Diode Recovery Times**



**Figure 19: Unclamped Inductive Waferform**

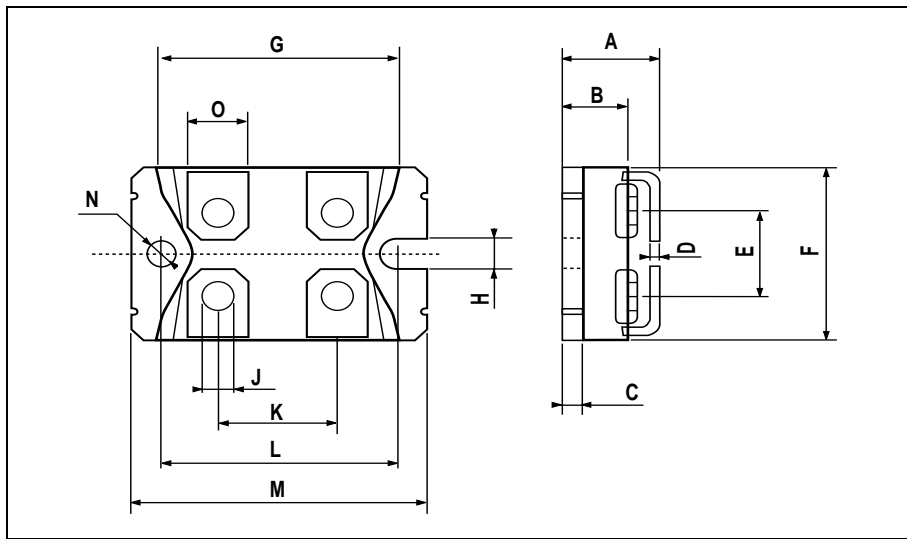


**Figure 20: Gate Charge Test Circuit**



**ISOTOP MECHANICAL DATA**

DIM.	mm			inch		
	MIN.	TYP.	MAX.	MIN.	TYP.	MAX.
A	11.8		12.2	0.466		0.480
B	8.9		9.1	0.350		0.358
C	1.95		2.05	0.076		0.080
D	0.75		0.85	0.029		0.033
E	12.6		12.8	0.496		0.503
F	25.15		25.5	0.990		1.003
G	31.5		31.7	1.240		1.248
H	4			0.157		
J	4.1		4.3	0.161		0.169
K	14.9		15.1	0.586		0.594
L	30.1		30.3	1.185		1.193
M	37.8		38.2	1.488		1.503
N	4			0.157		
O	7.8		8.2	0.307		0.322





**Table 10: Revision History**

<b>Date</b>	<b>Revision</b>	<b>Description of Changes</b>
12-May-2004	1	First Release.
15-Oct-2004	2	New value inserted in table 3. ( $V_{ISO}$ )
20-Jan-2005	3	Final Datasheet

Information furnished is believed to be accurate and reliable. However, STMicroelectronics assumes no responsibility for the consequences of use of such information nor for any infringement of patents or other rights of third parties which may result from its use. No license is granted by implication or otherwise under any patent or patent rights of STMicroelectronics. Specifications mentioned in this publication are subject to change without notice. This publication supersedes and replaces all information previously supplied. STMicroelectronics products are not authorized for use as critical components in life support devices or systems without express written approval of STMicroelectronics.

The ST logo is a registered trademark of STMicroelectronics

All other names are the property of their respective owners

© 2005 STMicroelectronics - All Rights Reserved

STMicroelectronics group of companies

Australia - Belgium - Brazil - Canada - China - Czech Republic - Finland - France - Germany - Hong Kong - India - Israel - Italy - Japan - Malaysia - Malta - Morocco - Singapore - Spain - Sweden - Switzerland - United Kingdom - United States of America