

# MOS INTEGRATED CIRCUIT

# $\mu$ PD784218, 784218Y

## 16-/8-BIT SINGLE-CHIP MICROCONTROLLERS

### DESCRIPTION

The  $\mu$ PD784218 is a member of the  $\mu$ PD784218 Subseries of the 78K/IV Series. In addition to a high-speed and high-performance CPU, the  $\mu$ PD784218 incorporates a variety of peripheral hardware such as ROM, RAM, I/O ports, 8-bit resolution A/D and D/A converters, timers, serial interfaces, real-time output ports, and an interrupt function.

The  $\mu$ PD784218Y<sup>Note</sup> is the  $\mu$ PD784218 Subseries with a multi-master supporting I<sup>2</sup>C bus interface added.

Flash memory versions, the  $\mu$ PD78F4218 and 78F4218Y, which can operate in the same voltage range as the mask ROM versions, and various development tools are also available.

**Note** Under development

Detailed function descriptions are provided in the following user's manuals. Be sure to read them before designing.

$\mu$ PD784218, 784218Y Subseries User's Manual Hardware: U12970E

78K/IV Series User's Manual Instructions:

U10905E

### FEATURES

- On-chip ROM correction function
- Inherits peripheral functions of  $\mu$ PD78078Y Subseries
- Minimum instruction execution time  
160 ns  
(@  $f_{xx} = 12.5$  MHz operation with main system clock)  
61  $\mu$ s  
(@  $f_{XT} = 32.768$  kHz operation with subsystem clock)
- Internal high-capacity memory
  - ROM: 256 KB
  - RAM: 12,800 bytes
- I/O ports: 86
- Timer/counters: 16-bit timer/event counter  $\times$  1 unit  
8-bit timer/event counter  $\times$  6 units
- Serial interfaces: 3 channels  
UART/IOE (3-wire serial I/O): 2 channels  
CSI (3-wire serial I/O, multi-master supporting I<sup>2</sup>C bus<sup>Note</sup>): 1 channel
- Standby function  
HALT/STOP/IDLE mode  
In power-saving mode: HALT/IDLE mode (with subsystem clock)
- Clock division function
- Watch timer: 1 channel
- Watchdog timer: 1 channel
- Clock output function  
Selectable from  $f_{xx}$ ,  $f_{xx}/2$ ,  $f_{xx}/2^2$ ,  $f_{xx}/2^3$ ,  $f_{xx}/2^4$ ,  $f_{xx}/2^5$ ,  $f_{xx}/2^6$ ,  $f_{xx}/2^7$ ,  $f_{XT}$
- Buzzer output function  
Selectable from  $f_{xx}/2^{10}$ ,  $f_{xx}/2^{11}$ ,  $f_{xx}/2^{12}$ ,  $f_{xx}/2^{13}$
- A/D converter: 8-bit resolution  $\times$  8 channels
- D/A converter: 8-bit resolution  $\times$  2 channels
- Supply voltage:  $V_{DD} = 2.2$  to 5.5 V

**Note**  $\mu$ PD784218Y only

Unless otherwise specified, references in this document to the  $\mu$ PD784218 refer to the  $\mu$ PD784218 and the  $\mu$ PD784218Y.

The information in this document is subject to change without notice. Before using this document, please confirm that this is the latest version.

Not all devices/types available in every country. Please check with local NEC representative for availability and additional information.

**APPLICATIONS**

Cellular phones, personal handy phone system (PHS), cordless telephones, CD-ROM, AV equipment

**ORDERING INFORMATION**

Part Number	Package	Internal ROM (Bytes)	Internal RAM (Bytes)
μPD784218GC-xxx-8EU	100-pin plastic LQFP (fine pitch) (14 × 14 mm)	256 K	12,800
μPD784218GF-xxx-3BA	100-pin plastic QFP (14 × 20 mm)	256 K	12,800
μPD784218YGC-xxx-8EU <sup>Note</sup>	100-pin plastic LQFP (fine pitch) (14 × 14 mm)	256 K	12,800
μPD784218YGF-xxx-3BA <sup>Note</sup>	100-pin plastic QFP (14 × 20 mm)	256 K	12,800

**Note** Under development

**Remark** xxx indicates ROM code suffix.

★ 78K/IV SERIES LINEUP

: Under mass production

: Under development

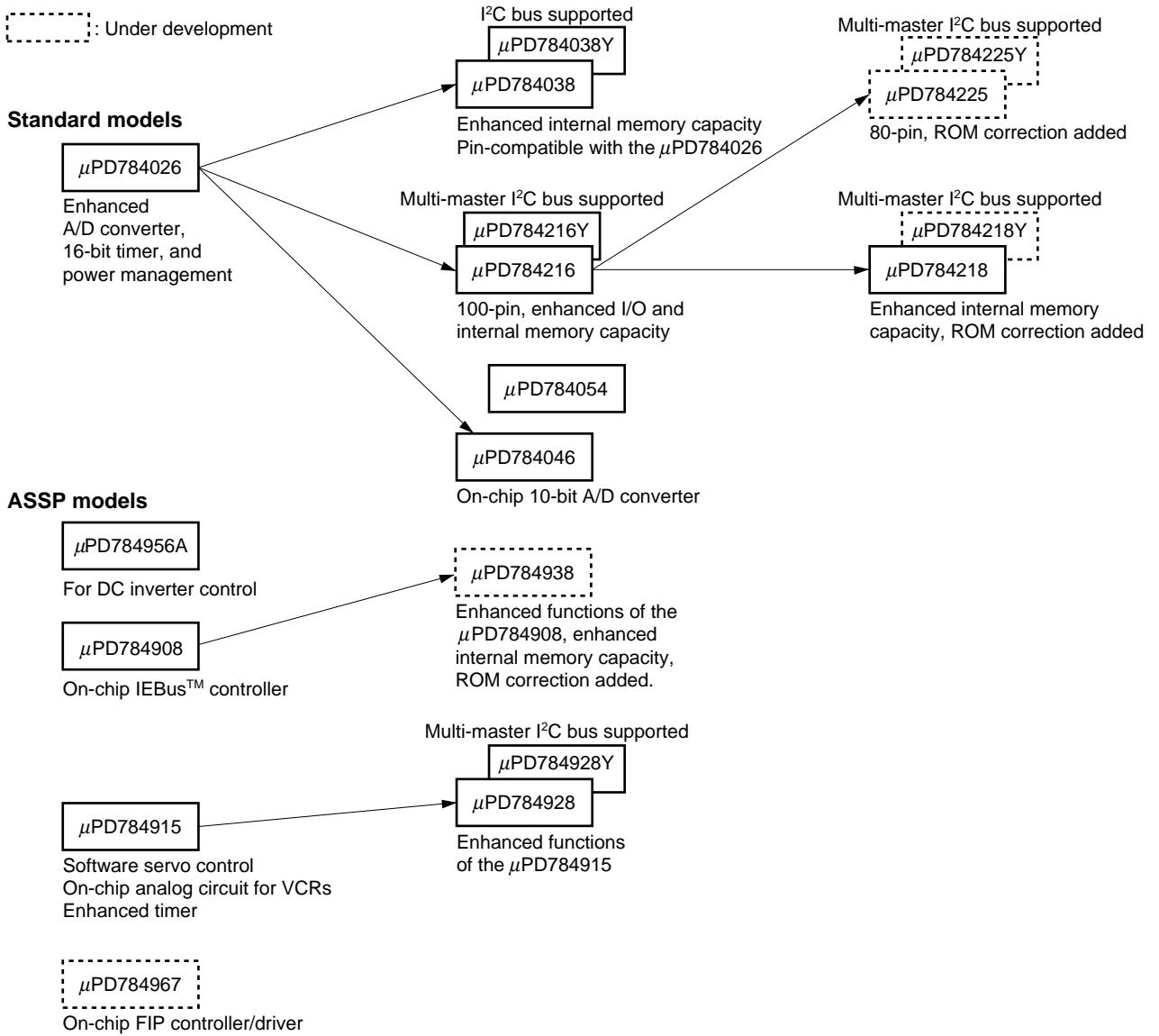

OVERVIEW OF FUNCTIONS (1/2)

Part Number		μPD784218, μPD784218Y <sup>Note 1</sup>	
Item			
Number of basic instructions (mnemonics)	113		
General-purpose registers	8 bits × 16 registers × 8 banks, or 16 bits × 8 registers × 8 banks (memory mapping)		
Minimum instruction execution time	<ul style="list-style-type: none"> <li>• 160 ns/320 ns/640 ns/1,280 ns/2,560 ns (@ f<sub>xx</sub> = 12.5 MHz operation with main system clock)</li> <li>• 61 μs (@ f<sub>XT</sub> = 32.768 kHz operation with subsystem clock)</li> </ul>		
Internal memory	ROM	256 KB	
	RAM	12,800 bytes	
Memory space	1 MB with program and data spaces combined		
I/O ports	Total	86	
	CMOS input	8	
	CMOS I/O	72	
	N-ch open-drain I/O	6	
Pins with ancillary functions <sup>Note 2</sup>	Pins with pull-up resistor	70	
	LED direct drive outputs	22	
	Middle-voltage pins	6	
Real-time output port	4 bits × 2, or 8 bits × 1		
Timer/counters	Timer/event counter: (16-bit)	Timer counter × 1 Capture/compare register × 2	Pulse output • PPG output • Square wave output • One-shot pulse output
	Timer/event counter 1: (8-bit)	Timer counter × 1 Compare register × 1	Pulse output • PWM output • Square wave output
	Timer/event counter 2: (8-bit)	Timer counter × 1 Compare register × 1	Pulse output • PWM output • Square wave output
	Timer/event counter 5: (8-bit)	Timer counter × 1 Compare register × 1	Pulse output • PWM output • Square wave output
	Timer/event counter 6: (8-bit)	Timer counter × 1 Compare register × 1	Pulse output • PWM output • Square wave output
	Timer/event counter 7: (8-bit)	Timer counter × 1 Compare register × 1	Pulse output • PWM output • Square wave output
	Timer/event counter 8: (8-bit)	Timer counter × 1 Compare register × 1	Pulse output • PWM output • Square wave output
Serial interfaces	<ul style="list-style-type: none"> <li>• UART/IOE (3-wire serial I/O): 2 channels (on-chip baud rate generator)</li> <li>• CSI (3-wire serial I/O, multi-master supporting I<sup>2</sup>C bus<sup>Note 3</sup>): 1 channel</li> </ul>		
A/D converter	8-bit resolution × 8 channels		
D/A converter	8-bit resolution × 2 channels		

- Notes**
1. Under development
  2. The pins with ancillary functions are included in the I/O pins.
  3. μPD784218Y only

OVERVIEW OF FUNCTIONS (2/2)

Part Number		μPD784218, μPD784218Y <sup>Note</sup>
Item		
Clock output	Selectable from $f_{xx}$ , $f_{xx}/2$ , $f_{xx}/2^2$ , $f_{xx}/2^3$ , $f_{xx}/2^4$ , $f_{xx}/2^5$ , $f_{xx}/2^6$ , $f_{xx}/2^7$ , $f_{XT}$	
Buzzer output	Selectable from $f_{xx}/2^{10}$ , $f_{xx}/2^{11}$ , $f_{xx}/2^{12}$ , $f_{xx}/2^{13}$	
Watch timer	1 channel	
Watchdog timer	1 channel	
Standby	<ul style="list-style-type: none"> <li>• HALT/STOP/IDLE modes</li> <li>• In low-power consumption mode (with subsystem clock): HALT/IDLE mode</li> </ul>	
Interrupts	Hardware sources	29 (internal: 20, external: 9)
	Software sources	BRK instruction, BRKCS instruction, operand error
	Non-maskable	Internal: 1, external: 1
	Maskable	Internal: 19, external: 8
		<ul style="list-style-type: none"> <li>• 4 programmable priority levels</li> <li>• 3 service modes: vectored interrupt/macro service/context switching</li> </ul>
Supply voltage	$V_{DD} = 2.2$ to $5.5$ V	
Package	100-pin plastic LQFP (fine pitch) (14 × 14 mm) 100-pin plastic QFP (14 × 20 mm)	

**Note** Under development

**CONTENTS**

<b>1. DIFFERENCES AMONG MODELS IN μPD784218, 784218Y SUBSERIES .....</b>	<b>8</b>
<b>2. DIFFERENCES BETWEEN μPD784218 AND μPD784216 .....</b>	<b>8</b>
<b>3. MAJOR DIFFERENCES FROM μPD78078, 78078Y SUBSERIES .....</b>	<b>9</b>
<b>4. PIN CONFIGURATION (TOP VIEW) .....</b>	<b>10</b>
<b>5. BLOCK DIAGRAM .....</b>	<b>13</b>
<b>6. PIN FUNCTIONS .....</b>	<b>14</b>
<b>6.1 Port Pins .....</b>	<b>14</b>
<b>6.2 Non-Port Pins .....</b>	<b>16</b>
<b>6.3 Pin I/O Circuits and Recommended Connections of Unused Pins .....</b>	<b>18</b>
<b>7. CPU ARCHITECTURE .....</b>	<b>22</b>
<b>7.1 Memory Space .....</b>	<b>22</b>
<b>7.2 CPU Registers .....</b>	<b>24</b>
7.2.1 General-purpose registers .....	24
7.2.2 Control registers .....	25
7.2.3 Special function registers (SFRs) .....	26
<b>8. PERIPHERAL HARDWARE FUNCTION FEATURES .....</b>	<b>31</b>
<b>8.1 Ports .....</b>	<b>31</b>
<b>8.2 Clock Generator .....</b>	<b>32</b>
<b>8.3 Real-Time Output Port .....</b>	<b>34</b>
<b>8.4 Timer/Event Counter .....</b>	<b>35</b>
<b>8.5 A/D Converter .....</b>	<b>37</b>
<b>8.6 D/A Converter .....</b>	<b>38</b>
<b>8.7 Serial Interfaces .....</b>	<b>39</b>
8.7.1 Asynchronous serial interface/3-wire serial I/O (UART/IOE) .....	40
8.7.2 Clocked serial interface (CSI) .....	42
<b>8.8 Clock Output Function .....</b>	<b>43</b>
<b>8.9 Buzzer Output Function .....</b>	<b>44</b>
<b>8.10 Edge Detection Function .....</b>	<b>44</b>
<b>8.11 Watch Timer .....</b>	<b>44</b>
<b>8.12 Watchdog Timer .....</b>	<b>45</b>
<b>9. INTERRUPT FUNCTION .....</b>	<b>46</b>
<b>9.1 Interrupt Sources .....</b>	<b>46</b>
<b>9.2 Vectored Interrupt .....</b>	<b>48</b>
<b>9.3 Context Switching .....</b>	<b>49</b>
<b>9.4 Macro Service .....</b>	<b>49</b>
<b>9.5 Application Example of Macro Service .....</b>	<b>50</b>

10. LOCAL BUS INTERFACE .....	51
10.1 Memory Expansion .....	52
10.2 Programmable Wait .....	52
10.3 External Access Status Function .....	52
11. STANDBY FUNCTION.....	53
12. RESET FUNCTION.....	55
13. ROM CORRECTION .....	56
14. INSTRUCTION SET .....	57
15. ELECTRICAL SPECIFICATIONS .....	62
16. PACKAGE DRAWINGS .....	81
★ 17. RECOMMENDED SOLDERING CONDITIONS .....	83
APPENDIX A DEVELOPMENT TOOLS .....	84
APPENDIX B RELATED DOCUMENTS .....	87

★ 1. DIFFERENCES AMONG MODELS IN μPD784218, 784218Y SUBSERIES

The μPD784218Y is the μPD784218 with I<sup>2</sup>C bus control added.

The μPD78F4218 and 78F4218Y are provided with a 256 KB flash memory instead of the mask ROM of the above models. These differences are summarized in Table 1-1.

**Table 1-1. Differences Among Models in μPD784218, 784218Y Subseries**

Part Number Item	μPD784218, μPD784218Y	μPD78F4218, μPD78F4218Y
Internal ROM	256 KB (mask ROM)	256 KB (Flash memory)
Internal RAM	12,800 bytes	
Internal memory size switching register (IMS)	None	Provided <sup>Note</sup>
Supply voltage	V <sub>DD</sub> = 2.2 to 5.5 V	V <sub>DD</sub> = 2.7 to 5.5 V
Electrical specifications	Refer to the data sheet for each device.	
Recommended soldering conditions		
TEST pin	Provided	None
V <sub>PP</sub> pin	None	Provided

**Note** The internal flash memory capacity and internal RAM capacity can be changed using the internal memory size switching register (IMS).

**Caution** There are differences in noise immunity and noise radiation between the flash memory and mask ROM versions. When pre-producing an application set with the flash memory version and then mass-producing it with the mask ROM version, be sure to conduct sufficient evaluations on the commercial samples (not engineering samples) of the mask ROM version.

2. DIFFERENCES BETWEEN μPD784218 AND μPD784216

Table 2-1 shows the differences between the μPD784218 and μPD784216.

**Table 2-1. Differences between μPD784218 and μPD784216**

Part Number Item	μPD784218	μPD784216
Internal ROM	256 KB	128 KB
Internal RAM	12,800 bytes	8,192 bytes
ROM correction	Provided	None
External access status function	Provided	None



3. MAJOR DIFFERENCES FROM μPD78078, 78078Y SUBSERIES

Series Name		μPD784218, 784218Y Subseries	μPD78078, 78078Y Subseries
Item			
CPU		16-bit CPU	8-bit CPU
Minimum instruction execution time	With main system clock	160 ns (@ 12.5 MHz operation)	400 ns (@ 5.0 MHz operation)
	With subsystem clock	61 μs (@ 32.768 kHz operation)	122 μs (@ 32.768 kHz operation)
Memory space		1 MB	64 KB
I/O ports	Total	86	88
	CMOS input	8	2
	CMOS I/O	72	78
	N-ch open-drain I/O	6	8
Pins with ancillary functions <sup>Note 1</sup>	Pins with pull-up resistor	70	86
	LED direct drive outputs	22	16
	Middle-voltage pins	6	8
Timer/counters		<ul style="list-style-type: none"> <li>• 16-bit timer/event counter × 1 unit</li> <li>• 8-bit timer/event counter × 6 units</li> </ul>	<ul style="list-style-type: none"> <li>• 16-bit timer/event counter × 1 unit</li> <li>• 8-bit timer/event counter × 4 units</li> </ul>
Serial interfaces		<ul style="list-style-type: none"> <li>• UART/IOE (3-wire serial I/O) × 2 channels</li> <li>• CSI (3-wire serial I/O, multi-master supporting I<sup>2</sup>C bus<sup>Note 2</sup>) × 1 channel</li> </ul>	<ul style="list-style-type: none"> <li>• UART/IOE (3-wire serial I/O) × 1 channel</li> <li>• CSI (3-wire serial I/O, 2-wire serial I/O, I<sup>2</sup>C bus<sup>Note 3</sup>) × 1 channel</li> <li>• CSI (3-wire serial I/O, 3-wire serial I/O with automatic transmit/receive function) × 1 channel</li> </ul>
Interrupts	NMI pin	Provided	None
	Macro service	Provided	None
	Context switching	Provided	None
	Programmable priority	4 levels	None
Standby function		HALT/STOP/IDLE modes In low-power consumption mode: HALT/IDLE modes	HALT/STOP modes
ROM correction		Provided	None
External access status function		Provided	None
Package		<ul style="list-style-type: none"> <li>• 100-pin plastic LQFP (fine pitch) (14 × 14 mm)</li> <li>• 100-pin plastic QFP (14 × 20 mm)</li> </ul>	<ul style="list-style-type: none"> <li>• 100-pin plastic LQFP (fine pitch) (14 × 14 mm)</li> <li>• 100-pin plastic QFP (14 × 20 mm)</li> <li>• 100-pin ceramic WQFN (14 × 20 mm) (μPD78P078 and 78P078Y only)</li> </ul>

**Notes** 1. The pins with ancillary functions are included in the I/O pins.

2. μPD784218Y Subseries only

3. μPD78078Y Subseries only

4. PIN CONFIGURATION (TOP VIEW)

- 100-pin plastic LQFP (fine pitch) (14 × 14 mm)  
 μPD784218GC-xxx-8EU, 784218YGC-xxx-8EU<sup>Note 5</sup>

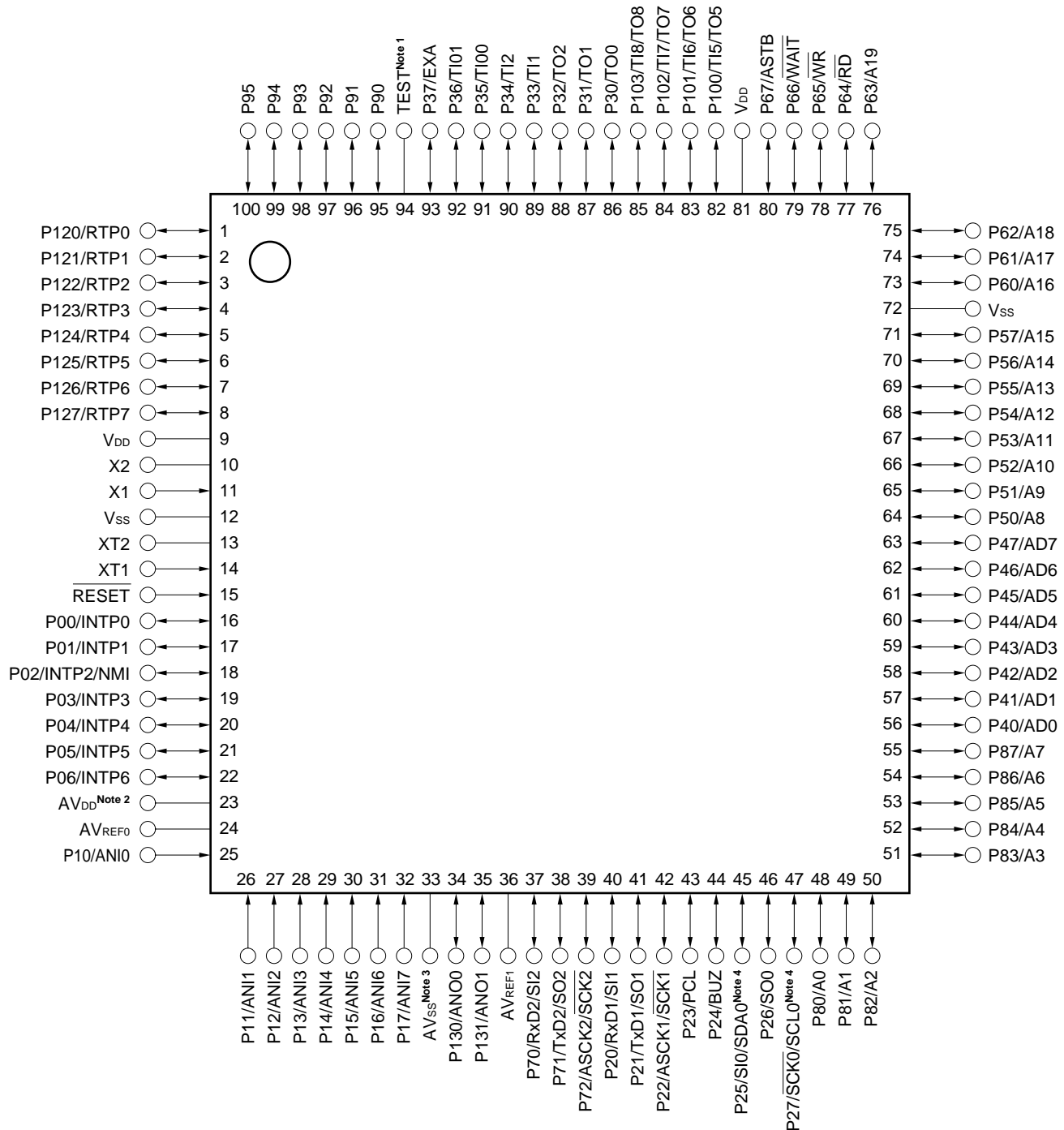

- Notes**
1. Connect the TEST pin directly to V<sub>SS</sub> or pull down. For the pull-down connection, use of a resistor whose resistance is between 470 Ω and 10 kΩ is recommended.
  2. Connect the AV<sub>DD</sub> pin to V<sub>DD</sub>.
  3. Connect the AV<sub>SS</sub> pin to V<sub>SS</sub>.
  4. The SCL0 and SDA0 pins are incorporated only in the μPD784218Y.
  5. Under development

★

- 100-pin plastic QFP (14 × 20 mm)
- μPD784218GF-xxx-3BA, 784218YGF-xxx-3BA <sup>Note 5</sup>

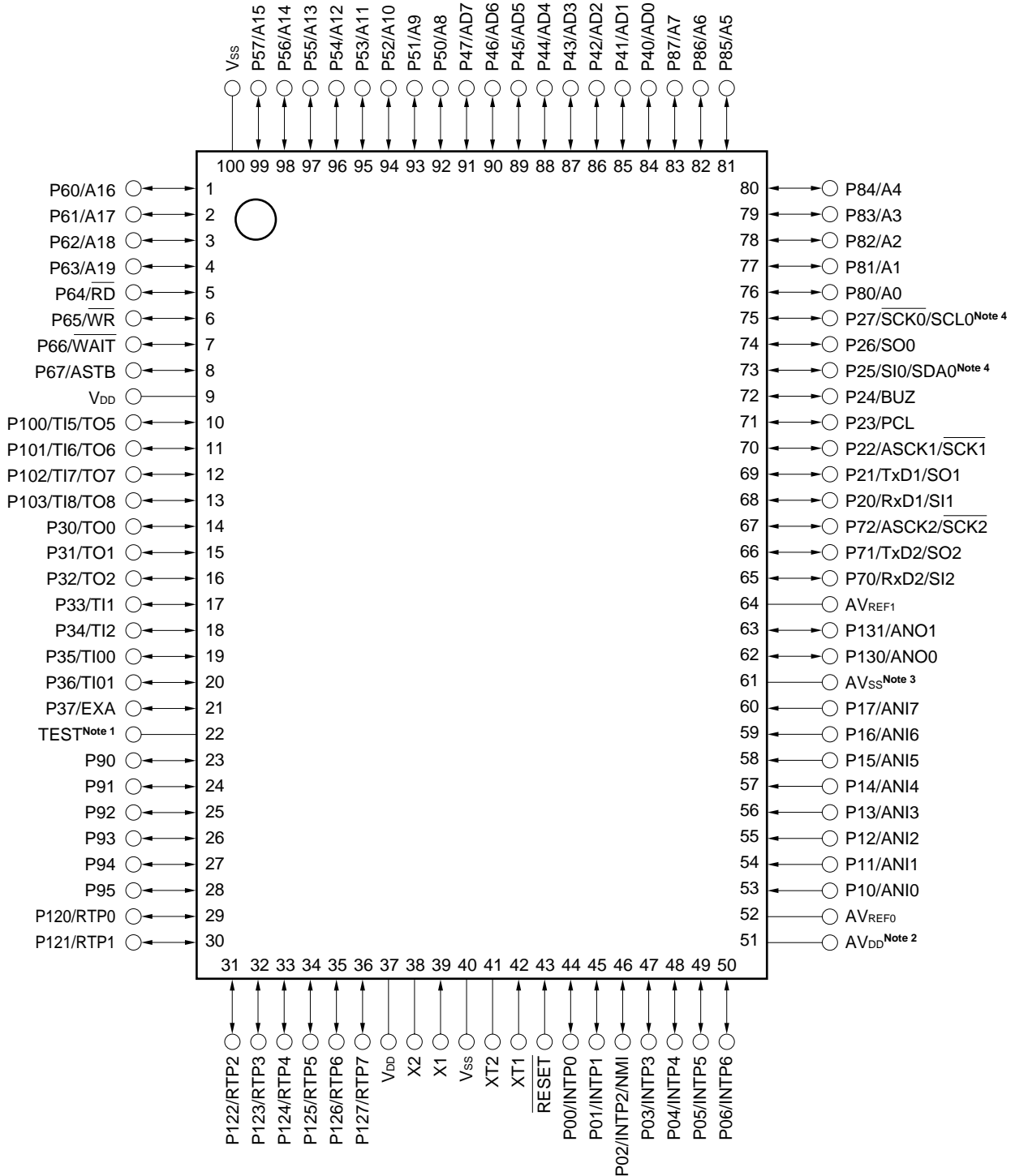

- Notes**
1. Connect the TEST pin directly to Vss or pull down. For the pull-down connection, use of a resistor whose resistance is between 470 Ω and 10 kΩ is recommended.
  2. Connect the AVDD pin to VDD.
  3. Connect the AVss pin to Vss.
  4. The SCL0 and SDA0 pins are incorporated only in the μPD784218Y.
  5. Under development

★

A0 to A19:	Address Bus	P100 to P103:	Port 10
AD0 to AD7:	Address/Data Bus	P120 to P127:	Port 12
ANI0 to ANI7:	Analog Input	P130, P131:	Port 13
ANO0, ANO1:	Analog Output	PCL:	Programmable Clock
ASCK1, ASCK2	Asynchronous Serial Clock	$\overline{RD}$ :	Read Strobe
ASTB:	Address Strobe	$\overline{RESET}$ :	Reset
AV <sub>DD</sub> :	Analog Power Supply	RTP0 to RTP7:	Real-time Output Port
AV <sub>REF0</sub> , AV <sub>REF1</sub> :	Analog Reference Voltage	RxD1, RxD2:	Receive Data
AV <sub>SS</sub> :	Analog Ground	$\overline{SCK0}$ to $\overline{SCK2}$ :	Serial Clock
BUZ:	Buzzer Clock	SCL0 <sup>Note</sup> :	Serial Clock
EXA:	External Access Status Output	SDA0 <sup>Note</sup> :	Serial Data
INTP0 to INTP6:	Interrupt from Peripherals	SI0 to SI2:	Serial Input
NMI:	Non-maskable Interrupt	SO0 to SO2:	Serial Output
P00 to P06:	Port 0	TEST:	Test
P10 to P17:	Port 1	TI00, TI01,	
P20 to P27:	Port 2	TI1, TI2, TI5 to TI8:	Timer Input
P30 to P37:	Port 3	TO0 to TO2, TO5 to TO8:	Timer Output
P40 to P47:	Port 4	TxD1, TxD2:	Transmit Data
P50 to P57:	Port 5	V <sub>DD</sub> :	Power Supply
P60 to P67:	Port 6	V <sub>SS</sub> :	Ground
P70 to P72:	Port 7	$\overline{WAIT}$ :	Wait
P80 to P87:	Port 8	$\overline{WR}$ :	Write Strobe
P90 to P95:	Port 9	X1, X2:	Crystal (Main System Clock)
		XT1, XT2:	Crystal (Subsystem Clock)

**Note** The SCL0 and SDA0 pins are incorporated only in the μPD784218Y.

★ 5. BLOCK DIAGRAM

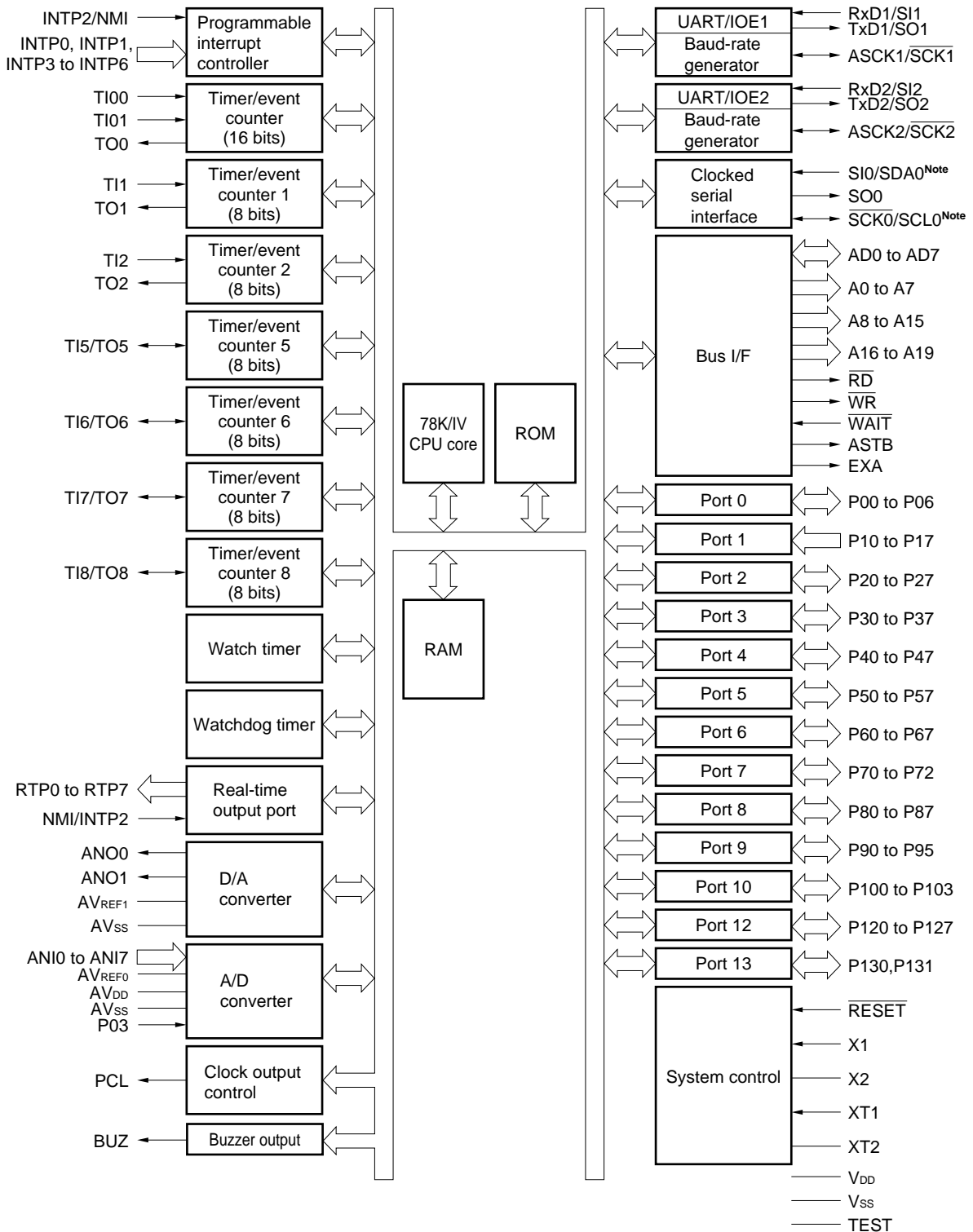

**Note** SDA0 and SCL0 are incorporated only in the μPD784218Y and support the I<sup>2</sup>C bus interface.

**Remark** The internal ROM capacity varies depending on the product.

6. PIN FUNCTIONS

6.1 Port Pins (1/2)

Pin Name	I/O	Alternate Function	Function
P00	I/O	INTP0	Port 0 (P0): <ul style="list-style-type: none"> <li>• 7-bit I/O port</li> <li>• Input/output can be specified in 1-bit units.</li> <li>• Whether specifying input mode or output mode, use of an on-chip pull-up resistor can be specified in 1-bit units by means of software.</li> </ul>
P01		INTP1	
P02		INTP2/NMI	
P03		INTP3	
P04		INTP4	
P05		INTP5	
P06		INTP6	
P10 to P17	Input	ANI0 to ANI7	Port 1 (P1): <ul style="list-style-type: none"> <li>• 8-bit input-only port</li> </ul>
P20	I/O	RxD1/SI1	Port 2 (P2): <ul style="list-style-type: none"> <li>• 8-bit I/O port</li> <li>• Input/output can be specified in 1-bit units.</li> <li>• Whether specifying input mode or output mode, use of an on-chip pull-up resistor can be specified in 1-bit units by means of software.</li> </ul>
P21		TxD1/SO1	
P22		ASCK1/ $\overline{\text{SCK1}}$	
P23		PCL	
P24		BUZ	
P25		SI0/SDA0 <sup>Note</sup>	
P26		SO0	
P27		$\overline{\text{SCK0}}$ /SCL0 <sup>Note</sup>	
P30	I/O	TO0	Port 3 (P3): <ul style="list-style-type: none"> <li>• 8-bit I/O port</li> <li>• Input/output can be specified in 1-bit units.</li> <li>• Whether specifying input mode or output mode, use of an on-chip pull-up resistor can be specified in 1-bit units by means of software.</li> </ul>
P31		TO1	
P32		TO2	
P33		TI1	
P34		TI2	
P35		TI00	
P36		TI01	
P37		EXA	
P40 to P47	I/O	AD0 to AD7	Port 4 (P4): <ul style="list-style-type: none"> <li>• 8-bit I/O port</li> <li>• Input/output can be specified in 1-bit units.</li> <li>• All pins set in input mode can be connected to on-chip pull-up resistors by means of software.</li> <li>• LEDs can be driven directly.</li> </ul>
P50 to P57	I/O	A8 to A15	Port 5 (P5): <ul style="list-style-type: none"> <li>• 8-bit I/O port</li> <li>• Input/output can be specified in 1-bit units.</li> <li>• All pins set in input mode can be connected to on-chip pull-up resistors by means of software.</li> <li>• LEDs can be driven directly.</li> </ul>

**Note** SDA0 and SCL0 are incorporated only in the μPD784218Y.

6.1 Port Pins (2/2)

Pin Name	I/O	Alternate Function	Function
P60	I/O	A16	Port 6 (P6): <ul style="list-style-type: none"> <li>• 8-bit I/O port</li> <li>• Input/output can be specified in 1-bit units.</li> <li>• All pins set in input mode can be connected to on-chip pull-up resistors by means of software.</li> </ul>
P61		A17	
P62		A18	
P63		A19	
P64		$\overline{RD}$	
P65		$\overline{WR}$	
P66		$\overline{WAIT}$	
P67		ASTB	
P70	I/O	RxD2/SI2	Port 7 (P7): <ul style="list-style-type: none"> <li>• 3-bit I/O port</li> <li>• Input/output can be specified in 1-bit units.</li> <li>• Whether specifying input mode or output mode, use of an on-chip pull-up resistor can be specified in 1-bit units by means of software.</li> </ul>
P71		TxD2/SO2	
P72		ASCK2/ $\overline{SCK2}$	
P80 to P87	I/O	A0 to A7	Port 8 (P8): <ul style="list-style-type: none"> <li>• 8-bit I/O port</li> <li>• Input/output can be specified in 1-bit units.</li> <li>• Whether specifying input mode or output mode, use of an on-chip pull-up resistor can be specified in 1-bit units by means of software.</li> <li>• The interrupt control flag (KRIF) is set to 1 when the falling edge is detected at a pin of this port.</li> </ul>
P90 to P95	I/O	—	Port 9 (P9): <ul style="list-style-type: none"> <li>• N-ch open-drain middle-voltage I/O port</li> <li>• 6-bit I/O port</li> <li>• Input/output can be specified in 1-bit units.</li> <li>• LEDs can be driven directly.</li> </ul>
P100	I/O	TI5/TO5	Port 10 (P10): <ul style="list-style-type: none"> <li>• 4-bit I/O port</li> <li>• Input/output can be specified in 1-bit units.</li> <li>• Whether specifying input mode or output mode, use of an on-chip pull-up resistor can be specified in 1-bit units by means of software.</li> </ul>
P101		TI6/TO6	
P102		TI7/TO7	
P103		TI8/TO8	
P120 to P127	I/O	RTP0 to RTP7	Port 12 (P12): <ul style="list-style-type: none"> <li>• 8-bit I/O port</li> <li>• Input/output can be specified in 1-bit units.</li> <li>• Whether specifying input mode or output mode, use of an on-chip pull-up resistor can be specified in 1-bit units by means of software.</li> </ul>
P130, P131	I/O	ANO0, ANO1	Port 13 (P13): <ul style="list-style-type: none"> <li>• 2-bit I/O port</li> <li>• Input/output can be specified in 1-bit units.</li> </ul>

6.2 Non-Port Pins (1/2)

Pin Name	I/O	Alternate Function	Function	
TI00	Input	P35	External count clock input to 16-bit timer counter	
TI01		P36	Capture trigger signal input to capture/compare register 00	
TI1		P33	External count clock input to 8-bit timer counter 1	
TI2		P34	External count clock input to 8-bit timer counter 2	
TI5		P100/TO5	External count clock input to 8-bit timer counter 5	
TI6		P101/TO6	External count clock input to 8-bit timer counter 6	
TI7		P102/TO7	External count clock input to 8-bit timer counter 7	
TI8		P103/TO8	External count clock input to 8-bit timer counter 8	
TO0		Output	P30	16-bit timer output (also used as 14-bit PWM output)
TO1	P31		8-bit timer output (also used as 8-bit PWM output)	
TO2	P32			
TO5	P100/TI5			
TO6	P101/TI6			
TO7	P102/TI7			
TO8	P103/TI8			
RxD1	Input			P20/SI1
RxD2		P70/SI2		Serial data input (UART2)
TxD1	Output	P21/SO1	Serial data output (UART1)	
TxD2		P71/SO2	Serial data output (UART2)	
ASCK1	Input	P22/ $\overline{\text{SCK1}}$	Baud rate clock input (UART1)	
ASCK2		P72/ $\overline{\text{SCK2}}$	Baud rate clock input (UART2)	
SI0	Input	P25/SDA0	Serial data input (3-wire serial clock I/O0)	
SI1		P20/RxD1	Serial data input (3-wire serial clock I/O1)	
SI2		P70/RxD2	Serial data input (3-wire serial clock I/O2)	
SO0	Output	P26	Serial data output (3-wire serial I/O0)	
SO1		P21/TxD1	Serial data output (3-wire serial I/O1)	
SO2		P71/TxD2	Serial data output (3-wire serial I/O2)	
SDA0 <sup>Note</sup>	I/O	P25/SI0	Serial data input/output (I <sup>2</sup> C bus)	
$\overline{\text{SCK0}}$		P27	Serial clock input/output (3-wire serial I/O0)	
$\overline{\text{SCK1}}$		P22/ASCK1	Serial clock input/output (3-wire serial I/O1)	
$\overline{\text{SCK2}}$		P72/ASCK2	Serial clock input/output (3-wire serial I/O2)	
SCL0 <sup>Note</sup>		P27/ $\overline{\text{SCK0}}$	Serial data input/output (I <sup>2</sup> C bus)	

**Note** Incorporated only in the μPD784218Y.



6.2 Non-Port Pins (2/2)

Pin Name	I/O	Alternate Function	Function
NMI	Input	P02/INTP2	Non-maskable interrupt request input
INTP0		P00	External interrupt request input
INTP1		P01	
INTP2		P02/NMI	
INTP3		P03	
INTP4		P04	
INTP5		P05	
INTP6		P06	
PCL	Output	P23	Clock output (for trimming main system clock and subsystem clock)
BUZ	Output	P24	Buzzer output
RTP0 to RTP7	Output	P120 to P127	Real-time output port that outputs data in synchronization with trigger
AD0 to AD7	I/O	P40 to P47	Lower address/data bus for expanding memory externally
A0 to A7	Output	P80 to P87	Lower address bus for expanding memory externally
A8 to A15		P50 to P57	Middle address bus for expanding memory externally
A16 to A19		P60 to P63	Higher address bus for expanding memory externally
$\overline{RD}$	Output	P64	Strobe signal output for read operation of external memory
$\overline{WR}$		P65	Strobe signal output for write operation of external memory
$\overline{WAIT}$	Input	P66	To insert wait state(s) when external memory is accessed
ASTB	Output	P67	Strobe output to externally latch address information output to ports 4 through 6 and port 8 to access external memory
EXA	Output	P37	Status signal output during external memory access
$\overline{RESET}$	Input	—	System reset input
X1	Input	—	Crystal connection for main system clock oscillation
X2	—		
XT1	Input	—	Crystal connection for subsystem clock oscillation
XT2	—		
ANI0 to ANI7	Input	P10 to P17	Analog voltage input for A/D converter
ANO0, ANO1	Output	P130, P131	Analog voltage output for D/A converter
AV <sub>REF0</sub>	—	—	To apply reference voltage for A/D converter
AV <sub>REF1</sub>			To apply reference voltage for D/A converter
AV <sub>DD</sub>			Positive power supply for A/D converter. Connect to V <sub>DD</sub> .
AV <sub>SS</sub>			GND for A/D converter and D/A converter. Connect to V <sub>SS</sub> .
V <sub>DD</sub>			Positive power supply
V <sub>SS</sub>			GND
TEST			Connect directly to V <sub>SS</sub> or pull down (this pin is for the IC test). For the pull-down connection, use of a resistor whose resistance is between 470 Ω and 10 kΩ is recommended.

**6.3 Pin I/O Circuits and Recommended Connections of Unused Pins**

The input/output circuit type of each pin and recommended connections of unused pins are shown in Table 6-1.

For the input/output circuit configuration of each type, refer to Figure 6-1.

★ **Table 6-1. Type of Pin Input/Output Circuits and Recommended Connections of Unused Pins (1/2)**

Pin Name	I/O Circuit Type	I/O	Recommended Connections of Unused Pins		
P00/INTP0	8-N	I/O	Input: Independently connect to V <sub>SS</sub> via a resistor Output: Leave open		
P01/INTP1					
P02/INTP2/NMI					
P03/INTP3 to P06/INTP6					
P10/ANI0 to P17/ANI7	9	Input	Connect to V <sub>SS</sub> or V <sub>DD</sub>		
P20/RxD1/SI1	10-K	I/O	Input: Independently connect to V <sub>SS</sub> via a resistor Output: Leave open		
P21/TxD1/SO1	10-L				
P22/ASCK1/ $\overline{\text{SCK1}}$	10-K				
P23/PCL	10-L				
P24/BUZ					
P25/SDA0 <sup>Note</sup> /SI0	10-K				
P26/SO0	10-L				
P27/SCL0 <sup>Note</sup> / $\overline{\text{SCK0}}$	10-K				
P30/TO0 to P32/TO2	12-E				
P33/TI1, P34/TI2	8-N				
P35/TI00, P36/TI01	10-M				
P37/EXA	12-E				
P40/AD0 to P47/AD7	5-A				
P50/A8 to P57/A15					
P60/A16 to P63/A19					
P64/ $\overline{\text{RD}}$					
P65/ $\overline{\text{WR}}$					
P66/ $\overline{\text{WAIT}}$					
P67/ASTB					
P70/RxD2/SI2	8-N				
P71/TxD2/SO2	10-M				
P72/ASCK2/ $\overline{\text{SCK2}}$	8-N				
P80/A0 to P87/A7	12-E				
P90 to P95	13-D				
P100/TI5/TO5	8-N				
P101/TI6/TO6					
P102/TI7/TO7					
P103/TI8/TO8					
P120/RTP0 to P127/RTP7	12-E				

**Note** SDA0 and SCL0 are incorporated only in the μPD784218Y.

Table 6-1. Types of Pin Input/Output Circuits and Recommended Connections of Unused Pins (2/2)

Pin Name	I/O Circuit Type	I/O	Recommended Connections of Unused Pins
P130/ANO0, P131/ANO1	12-F	I/O	Input: Independently connect to V <sub>SS</sub> via a resistor. Output: Leave open.
RESET	2-G	Input	—
XT1	16		Connect to V <sub>SS</sub>
XT2		—	Leave open
AV <sub>REF0</sub>	—		Connect to V <sub>SS</sub>
AV <sub>REF1</sub>			Connect to V <sub>DD</sub>
AV <sub>DD</sub>			
AV <sub>SS</sub>			Connect to V <sub>SS</sub>
TEST			Connect directly to V <sub>SS</sub> or pull down. For the pull-down connection, use of a resistor whose resistance is between 470 Ω and 10 kΩ is recommended.

**Remark** Because the circuit type numbers are standardized among the 78K Series products, they are not sequential in some models (i.e., some circuits are not provided).

★

Figure 6-1. Types of Pin I/O Circuits (1/2)

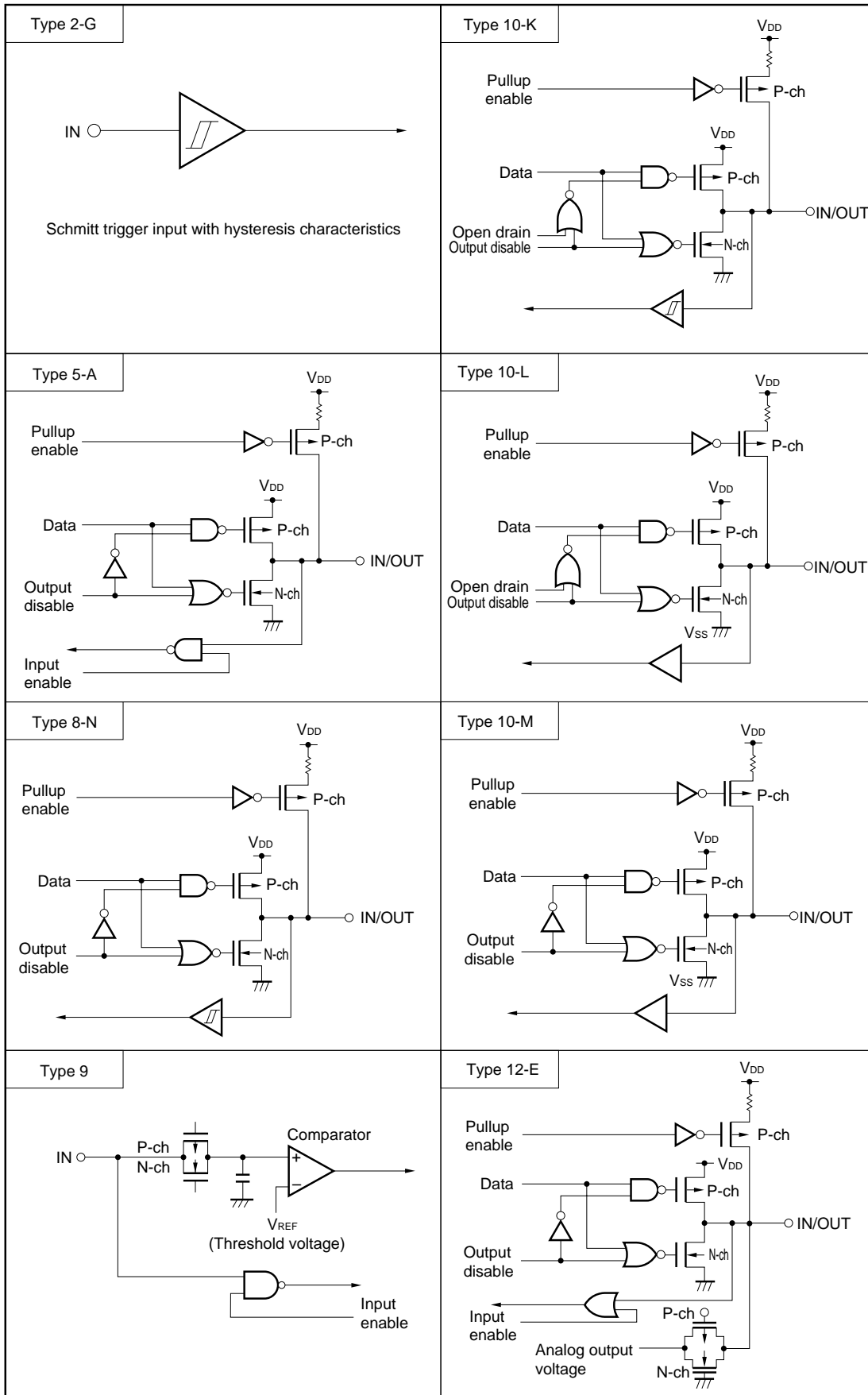

★

Figure 6-1. Types of Pin I/O Circuits (2/2)

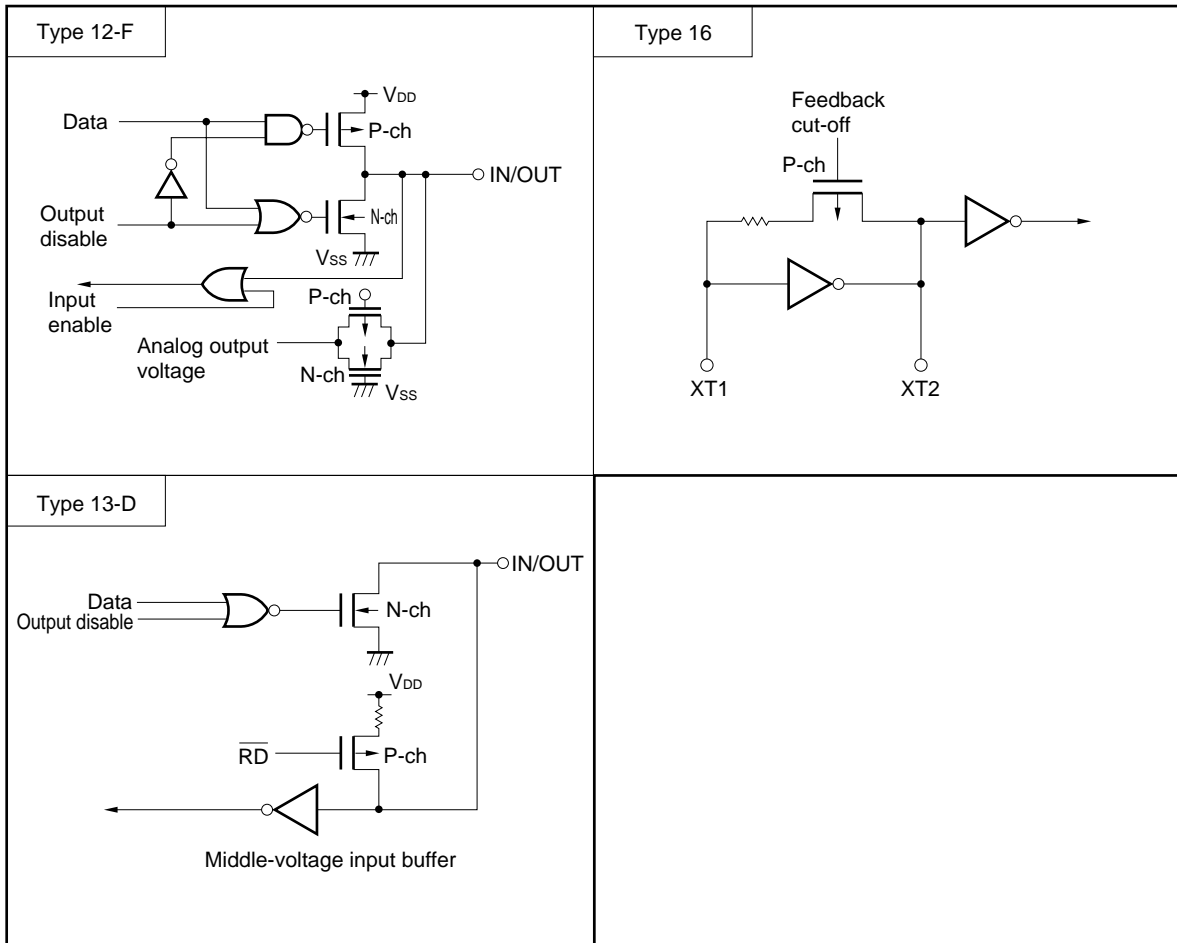

7. CPU ARCHITECTURE

★ 7.1 Memory Space

A memory space of 1 MB can be accessed. Mapping of the internal data area (special function registers and internal RAM) can be specified by the LOCATION instruction. The LOCATION instruction must always be executed after reset cancellation, and must not be used more than once.

(1) When LOCATION 0H instruction is executed

• Internal memory

The internal data area and internal ROM area are mapped as follows:

Part Number	Internal Data Area	Internal ROM Area
μPD784218, μPD784218Y	0CD00H to 0FFFFH	00000H to 0CCFFH 10000H to 3FFFFH

**Caution** The following areas that overlap the internal data area of the internal ROM cannot be used when the LOCATION 0 instruction is executed.

Part Number	Unusable Area
μPD784218, μPD784218Y	0CD00H to 0FFFFH (13,056 bytes)

• External memory

The external memory is accessed in external memory expansion mode.

(2) When LOCATION 0FH instruction is executed

• Internal memory

The internal data area and internal ROM area are mapped as follows:

Part Number	Internal Data Area	Internal ROM Area
μPD784218, μPD784218Y	FCD00H to FFFFFH	00000H to 3FFFFH

• External memory

The external memory is accessed in external memory expansion mode.

Figure 7-1. Memory Map of μPD784218, 784218Y

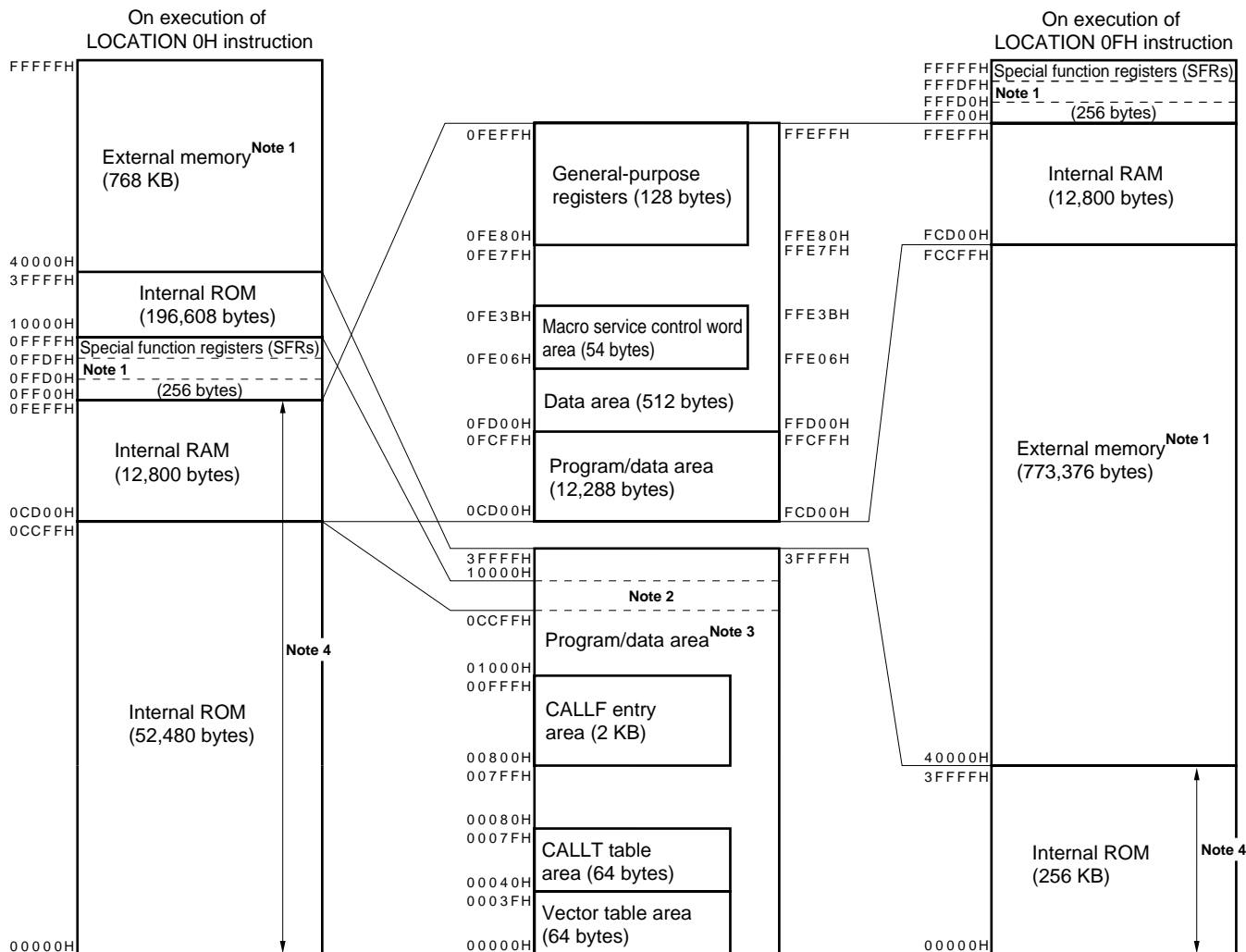

- Notes**
1. Accessed in external memory expansion mode.
  2. This 13,056-byte area can be used as internal ROM only when the LOCATION 0FH instruction is executed.
  3. On execution of LOCATION 0H instruction: 249,088 bytes, on execution of LOCATION 0FH instruction: 262,144 bytes
  4. Base area and entry area for reset or interrupt. However, the internal RAM area is not used as a reset entry area.

## 7.2 CPU Registers

### 7.2.1 General-purpose registers

Sixteen 8-bit general-purpose registers are available. Two 8-bit registers can be also used in pairs as a 16-bit register. Of the 16-bit registers, four can be used in combination with an 8-bit register for address expansion as 24-bit address specification registers.

Eight banks of these register sets are available and can be selected by using software or the context switching function.

The general-purpose registers except the V, U, T, and W registers for address expansion are mapped to the internal RAM.

Figure 7-2. General-Purpose Register Format

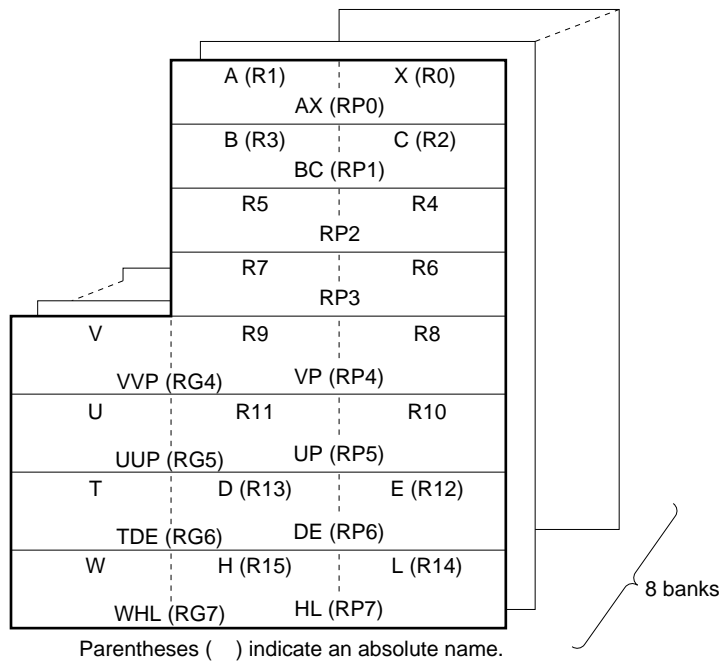

**Caution** Registers R4, R5, R6, R7, RP2, and RP3 can be used as the X, A, C, B, AX, and BC registers, respectively, by setting the RSS bit of the PSW to 1. However, use this function only for recycling the program of the 78K/III Series.



7.2.2 Control registers

(1) Program counter (PC)

The program counter is a 20-bit register whose contents are automatically updated when the program is executed.

Figure 7-3. Program Counter (PC) Format

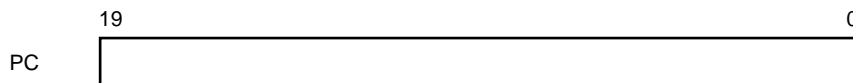

(2) Program status word (PSW)

This register holds the statuses of the CPU. Its contents are automatically updated when the program is executed.

Figure 7-4. Program Status Word (PSW) Format

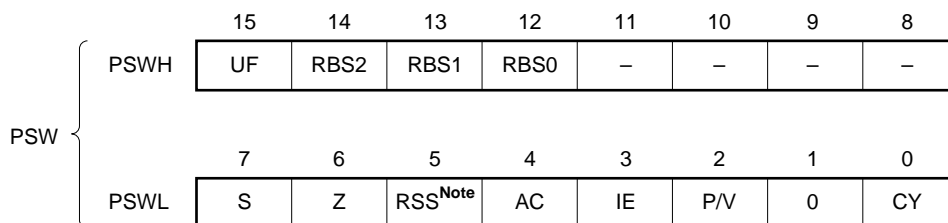

**Note** This flag is provided to maintain compatibility with the 78K/III Series. Be sure to clear this flag to 0, except when the software for the 78K/III Series is used.

(3) Stack pointer (SP)

This is a 24-bit pointer that holds the first address of the stack. Be sure to write 0 to the higher 4 bits of this pointer.

Figure 7-5. Stack Pointer (SP) Format

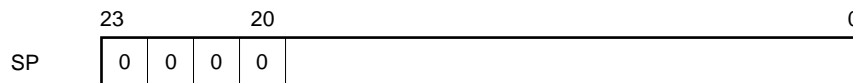

**7.2.3 Special function registers (SFRs)**

The special function registers, such as the mode registers and control registers of the internal peripheral hardware, are registers to which special functions are allocated. These registers are mapped to the 256-byte space of addresses 0FF00H through 0FFFFH<sup>Note</sup>.

**Note** On execution of the LOCATION 0H instruction. FFF00H through FFFFFH on execution of the LOCATION 0FH instruction.

**Caution** Do not access an address in this area to which no SFR is allocated. If such an address is accessed by mistake, the μPD784218 may enter a deadlock state. This deadlock state can be cleared only by inputting the RESET signal.

Table 7-1 lists the special function registers (SFRs). The meanings of the symbols in this table are as follows:

- Symbol ..... Symbol indicating an SFR. This symbol is reserved for NEC's assembler (RA78K4). It can be used as sfr variable by the #pragma sfr command with the C compiler (CC78K4).
- R/W ..... Indicates whether the SFR is read-only, write-only, or read/write.  
 R/W: Read/write  
 R: Read-only  
 W: Write-only
- Bit units for manipulation.. Bit units in which the value of the SFR can be manipulated.  
 SFRs that can be manipulated in 16-bit units can be described as the operand sfrp of an instruction. To specify the address of this SFR, describe an even address.  
 SFRs that can be manipulated in 1-bit units can be described as the operand of a bit manipulation instruction.
- After reset ..... Indicates the status of the register when the RESET signal has been input.

Table 7-1. Special Function Register (SFR) List (1/4)

Address <sup>Note 1</sup>	Special Function Register (SFR) Name	Symbol	R/W	Bit Units for Manipulation			After Reset	
				1 bit	8 bits	16 bits		
0FF00H	Port 0	P0	R/W	√	√	—	00H <sup>Note 2</sup>	
0FF01H	Port 1	P1	R	√	√	—		
0FF02H	Port 2	P2	R/W	√	√	—		
0FF03H	Port 3	P3		√	√	—		
0FF04H	Port 4	P4		√	√	—		
0FF05H	Port 5	P5		√	√	—		
0FF06H	Port 6	P6		√	√	—		
0FF07H	Port 7	P7		√	√	—		
0FF08H	Port 8	P8		√	√	—		
0FF09H	Port 9	P9		√	√	—		
0FF0AH	Port 10	P10		√	√	—		
0FF0CH	Port 12	P12		√	√	—		
0FF0DH	Port 13	P13		√	√	—		
0FF10H	16-bit timer counter	TM0		R	—	—		√
0FF11H								
0FF12H	Capture/compare register 00 (16-bit timer/event counter)	CR00	R/W	—	—	√		
0FF13H								
0FF14H	Capture/compare register 01 (16-bit timer/event counter)	CR01	R/W	—	—	√		
0FF15H								
0FF16H	Capture/compare control register 0	CRC0	R/W	√	√	—	00H	
0FF18H	16-bit timer mode control register	TMC0	R/W	√	√	—		
0FF1AH	16-bit timer output control register	TOC0	R/W	√	√	—		
0FF1CH	Prescaler mode register 0	PRM0	R/W	√	√	—		
0FF20H	Port mode 0 register	PM0	R/W	√	√	—	FFH	
0FF22H	Port mode 2 register	PM2	R/W	√	√	—		
0FF23H	Port mode 3 register	PM3	R/W	√	√	—		
0FF24H	Port mode 4 register	PM4	R/W	√	√	—		
0FF25H	Port mode 5 register	PM5	R/W	√	√	—		
0FF26H	Port mode 6 register	PM6	R/W	√	√	—		
0FF27H	Port mode 7 register	PM7	R/W	√	√	—		
0FF28H	Port mode 8 register	PM8	R/W	√	√	—		
0FF29H	Port mode 9 register	PM9	R/W	√	√	—		
0FF2AH	Port mode 10 register	PM10	R/W	√	√	—		
0FF2CH	Port mode 12 register	PM12	R/W	√	√	—		
0FF2DH	Port mode 13 register	PM13	R/W	√	√	—		

- Notes**
1. When the LOCATION 0H instruction is executed. Add "F000H" to this value when the LOCATION 0FH instruction is executed.
  2. Because each port is initialized to input mode after reset, "00H" is not actually read. The output latch is initialized to "0".

Table 7-1. Special Function Register (SFR) List (2/4)

Address <sup>Note</sup>	Special Function Register (SFR) Name	Symbol	R/W	Bit Units for Manipulation			After Reset
				1 bit	8 bits	16 bits	
0FF30H	Pull-up resistor option register 0	PU0	R/W	√	√	—	00H
0FF32H	Pull-up resistor option register 2	PU2		√	√	—	
0FF33H	Pull-up resistor option register 3	PU3		√	√	—	
0FF37H	Pull-up resistor option register 7	PU7		√	√	—	
0FF38H	Pull-up resistor option register 8	PU8		√	√	—	
0FF3AH	Pull-up resistor option register 10	PU10		√	√	—	
0FF3CH	Pull-up resistor option register 12	PU12		√	√	—	
0FF40H	Clock output control register	CKS		√	√	—	
0FF42H	Port function control register	PF2		√	√	—	
0FF4EH	Pull-up resistor option register	PUO		√	√	—	
0FF50H	8-bit timer counter 1	TM1	R	—	√	√	0000H
0FF51H	8-bit timer counter 2	TM2		—	√		
0FF52H	Compare register 10 (8-bit timer/event counter 1)	CR10	R/W	—	√	√	
0FF53H	Compare register 20 (8-bit timer/event counter 2)	CR20		—	√		
0FF54H	8-bit timer mode control register 1	TMC1	R/W	√	√	√	
0FF55H	8-bit timer mode control register 2	TMC2		√	√		
0FF56H	Prescaler mode register 1	PRM1	R/W	√	√	√	
0FF57H	Prescaler mode register 2	PRM2		√	√		
0FF60H	8-bit timer counter 5	TM5	R	—	√	√	
0FF61H	8-bit timer counter 6	TM6		—	√		
0FF62H	8-bit timer counter 7	TM7	R/W	—	√	√	
0FF63H	8-bit timer counter 8	TM8		—	√		
0FF64H	Compare register 50 (8-bit timer/event counter 5)	CR50	R/W	—	√	√	
0FF65H	Compare register 60 (8-bit timer/event counter 6)	CR60		—	√		
0FF66H	Compare register 70 (8-bit timer/event counter 7)	CR70	R/W	—	√	√	
0FF67H	Compare register 80 (8-bit timer/event counter 8)	CR80		—	√		
0FF68H	8-bit timer mode control register 5	TMC5	R/W	√	√	√	
0FF69H	8-bit timer mode control register 6	TMC6		√	√		
0FF6AH	8-bit timer mode control register 7	TMC7	R/W	√	√	√	
0FF6BH	8-bit timer mode control register 8	TMC8		√	√		
0FF6CH	Prescaler mode register 5	PRM5	R/W	√	√	√	
0FF6DH	Prescaler mode register 6	PRM6		√	√		
0FF6EH	Prescaler mode register 7	PRM7	R/W	√	√	√	
0FF6FH	Prescaler mode register 8	PRM8		√	√		
0FF70H	Asynchronous serial interface mode register 1	ASIM1	R	√	√	—	00H
0FF71H	Asynchronous serial interface mode register 2	ASIM2		√	√		
0FF72H	Asynchronous serial interface status register 1	ASIS1		√	√		
0FF73H	Asynchronous serial interface status register 2	ASIS2		√	√		

**Note** When the LOCATION 0H instruction is executed. Add "F0000H" to this value when the LOCATION 0FH instruction is executed.

Table 7-1. Special Function Register (SFR) List (3/4)

Address <sup>Note 1</sup>	Special Function Register (SFR) Name	Symbol	R/W	Bit Units for Manipulation			After Reset			
				1 bit	8 bits	16 bits				
0FF74H	Transmit shift register 1	TXS1	W	—	√	—	FFH			
	Receive buffer register 1	RXB1	R	—	√	—				
0FF75H	Transmit shift register 2	TXS2	W	—	√	—				
	Receive buffer register 2	RXB2	R	—	√	—				
0FF76H	Baud rate generator control register 1	BRGC1	R/W	√	√	—	00H			
0FF77H	Baud rate generator control register 2	BRGC2		√	√	—				
0FF7AH	Oscillation mode select register	CC		√	√	—				
0FF80H	A/D converter mode register	ADM		√	√	—				
0FF81H	A/D converter input select register	ADIS		√	√	—				
0FF83H	A/D conversion result register	ADCR		R	—	√		—	Undefined	
0FF84H	D/A conversion value setting register 0	DACS0	R/W	√	√	—	00H			
0FF85H	D/A conversion value setting register 1	DACS1		√	√	—				
0FF86H	D/A converter mode register 0	DAM0		√	√	—				
0FF87H	D/A converter mode register 1	DAM1		√	√	—				
0FF88H	ROM correction control register	CORC		√	√	—				
0FF89H	ROM correction address pointer H	CORAH		—	√	—				
0FF8AH	ROM correction address pointer L	CORAL		—	—	√		0000H		
0FF8BH										
0FF8CH	External bus type select register	EBTS		√	√	—		00H		
0FF8DH	External access status enable register	EXAE		√	√	—				
0FF90H	Serial operation mode register 0	CSIM0	√	√	—					
0FF91H	Serial operation mode register 1	CSIM1	√	√	—					
0FF92H	Serial operation mode register 2	CSIM2	√	√	—					
0FF94H	Serial I/O shift register 0	SIO0	—	√	—					
0FF95H	Serial I/O shift register 1	SIO1	—	√	—					
0FF96H	Serial I/O shift register 2	SIO2	—	√	—					
0FF98H	Real-time output buffer register L	RTBL	—	√	—					
0FF99H	Real-time output buffer register H	RTBH	—	√	—					
0FF9AH	Real-time output port mode register	RTPM	√	√	—					
0FF9BH	Real-time output port control register	RTPC	√	√	—					
0FF9CH	Watch timer mode control register	WTM	√	√	—					
0FFA0H	External interrupt rising edge enable register	EGP0	√	√	—					
0FFA2H	External interrupt falling edge enable register	EGN0	√	√	—					
0FFA8H	In-service priority register	ISPR	R	√	√		—			
0FFA9H	Interrupt select control register	SNMI	R/W	√	√		—	80H		
0FFAAH	Interrupt mode control register	IMC		√	√		—			
0FFACH	Interrupt mask flag register 0L	MK0L		MK0	√		√		√	FFFFH
0FFADH	Interrupt mask flag register 0H	MK0H			√		√			
0FFAEH	Interrupt mask flag register 1L	MK1L		MK1	√		√		√	
0FFAFH	Interrupt mask flag register 1H	MK1H			√		√			
0FFB0H	I <sup>2</sup> C bus control register <sup>Note 2</sup>	IICC0		√	√	—	00H			
0FFB2H	Prescaler mode register for serial clock	SRPM0		√	√	—				

**Notes** 1. When the LOCATION 0H instruction is executed. Add “F000H” to this value when the LOCATION 0FH instruction is executed.

2. μPD784218Y only

Table 7-1. Special Function Register (SFR) List (4/4)

Address <sup>Note 1</sup>	Special Function Register (SFR) Name	Symbol	R/W	Bit Units for Manipulation			After Reset	
				1 bit	8 bits	16 bits		
0FFB4H	Slave address register	SVA0	R/W	√	√	—	00H	
0FFB6H	I <sup>2</sup> C bus status register <sup>Note 2</sup>	IICS0	R	√	√	—		
0FFB8H	Serial shift register	IIC0	R/W	√	√	—		
0FFC0H	Standby control register	STBC		—	√	—		30H
0FFC2H	Watchdog timer mode register	WDM		—	√	—		00H
0FFC4H	Memory expansion mode register	MM		√	√	—		20H
0FFC7H	Programmable wait control register 1	PWC1		√	√	—		AAH
0FFCEH	Clock status register	PCS	R	√	√	—	32H	
0FFCFH	Oscillation stabilization time specification register	OSTS	R/W	√	√	—	00H	
0FFD0H to 0FFDFH	External SFR area	—		√	√	—	—	
0FFE0H	Interrupt control register (INTWDTM)	WDTIC		√	√	—	43H	
0FFE1H	Interrupt control register (INTP0)	PIC0		√	√	—		
0FFE2H	Interrupt control register (INTP1)	PIC1		√	√	—		
0FFE3H	Interrupt control register (INTP2)	PIC2		√	√	—		
0FFE4H	Interrupt control register (INTP3)	PIC3		√	√	—		
0FFE5H	Interrupt control register (INTP4)	PIC4		√	√	—		
0FFE6H	Interrupt control register (INTP5)	PIC5		√	√	—		
0FFE7H	Interrupt control register (INTP6)	PIC6		√	√	—		
0FFE8H	Interrupt control register (INTIIC0/INTCSI0)	CSIIC0		√	√	—		
0FFE9H	Interrupt control register (INTSER1)	SERIC1		√	√	—		
0FFEAH	Interrupt control register (INTSR1/INTCSI1)	SRIC1		√	√	—		
0FFEBH	Interrupt control register (INTST1)	STIC1		√	√	—		
0FFECH	Interrupt control register (INTSER2)	SERIC2		√	√	—		
0FFEDH	Interrupt control register (INTSR2/INTCSI2)	SRIC2		√	√	—		
0FFEEH	Interrupt control register (INTST2)	STIC2		√	√	—		
0FFEFH	Interrupt control register (INTTM3)	TMIC3		√	√	—		
0FFF0H	Interrupt control register (INTTM00)	TMIC00		√	√	—		
0FFF1H	Interrupt control register (INTTM01)	TMIC01		√	√	—		
0FFF2H	Interrupt control register (INTTM1)	TMIC1		√	√	—		
0FFF3H	Interrupt control register (INTTM2)	TMIC2		√	√	—		
0FFF4H	Interrupt control register (INTAD)	ADIC		√	√	—		
0FFF5H	Interrupt control register (INTTM5)	TMIC5		√	√	—		
0FFF6H	Interrupt control register (INTTM6)	TMIC6		√	√	—		
0FFF7H	Interrupt control register (INTTM7)	TMIC7		√	√	—		
0FFF8H	Interrupt control register (INTTM8)	TMIC8		√	√	—		
0FFF9H	Interrupt control register (INTWT)	WTIC		√	√	—		
0FFFAH	Interrupt control register (INTKR)	KRIC		√	√	—		

- Notes**
1. When the LOCATION 0H instruction is executed. Add "F000H" to this value when the LOCATION 0FH instruction is executed.
  2. μPD784218Y only

8. PERIPHERAL HARDWARE FUNCTION FEATURES

8.1 Ports

The ports shown in Figure 8-1 are provided to make various control operations possible. Table 8-1 shows the function of each port. Ports 0, 2 through 8, 10, and 12 can be connected to internal pull-up resistors by software when inputting.

Figure 8-1. Port Configuration

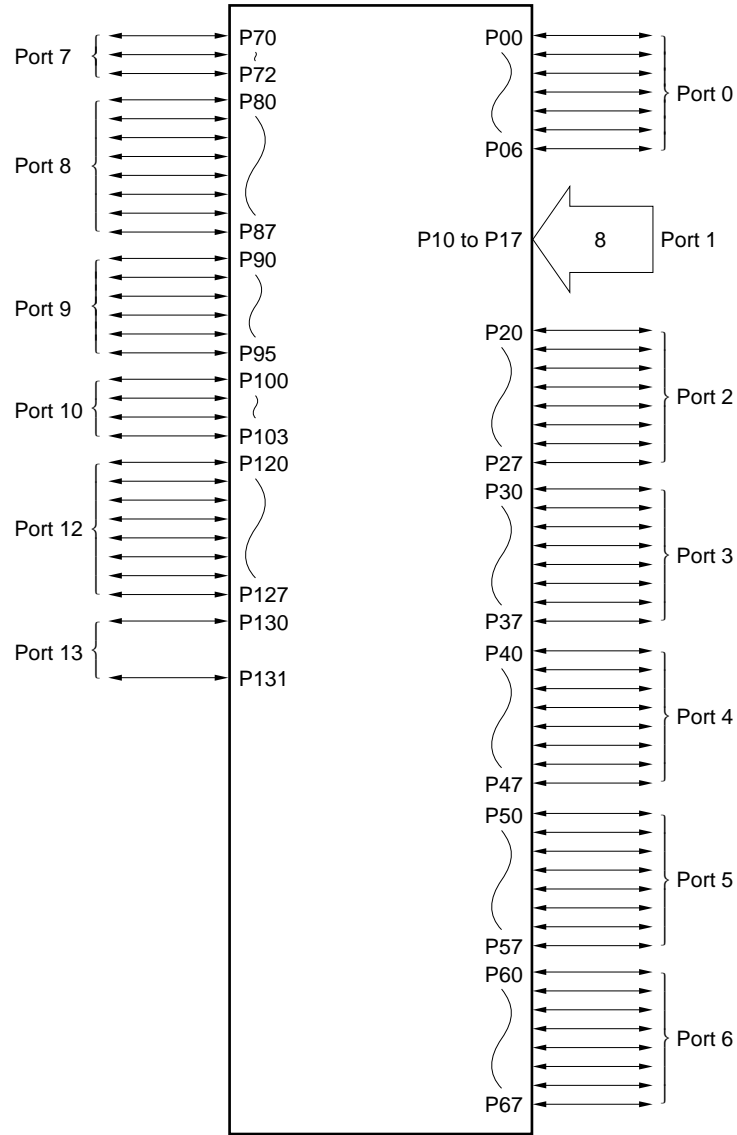

Table 8-1. Port Functions

Port Name	Pin Name	Function	Specification of Pull-up Resistor Connection by Software
Port 0	P00 to P06	• Can be set in input or output mode in 1-bit units	Can be specified in 1-bit units
Port 1	P10 to P17	• Input port	—
Port 2	P20 to P27	• Can be set in input or output mode in 1-bit units	Can be specified in 1-bit units
Port 3	P30 to P37	• Can be set in input or output mode in 1-bit units	Can be specified in 1-bit units
Port 4	P40 to P47	• Can be set in input or output mode in 1-bit units • Can directly drive LEDs	Can be specified in 1-port units
Port 5	P50 to P57	• Can be set in input or output mode in 1-bit units • Can directly drive LEDs	Can be specified in 1-port units
Port 6	P60 to P67	• Can be set in input or output mode in 1-bit units	Can be specified in 1-port units
Port 7	P70 to P72	• Can be set in input or output mode in 1-bit units	Can be specified in 1-bit units
Port 8	P80 to P87	• Can be set in input or output mode in 1-bit units	Can be specified in 1-bit units
Port 9	P90 to P95	• N-ch open-drain I/O port • Can be set in input or output mode in 1-bit units • Can directly drive LEDs	—
Port 10	P100 to P103	• Can be set in input or output mode in 1-bit units	Can be specified in 1-bit units
Port 12	P120 to P127	• Can be set in input or output mode in 1-bit units	Can be specified in 1-bit units
Port 13	P130, P131	• Can be set in input or output mode in 1-bit units	—

### 8.2 Clock Generator

An on-chip clock generator necessary for operation is provided. This clock generator has a frequency divider. If high-speed operation is not necessary, the internal operating frequency can be lowered by the frequency divider to reduce the current consumption.

★

Figure 8-2. Clock Generator Block Diagram

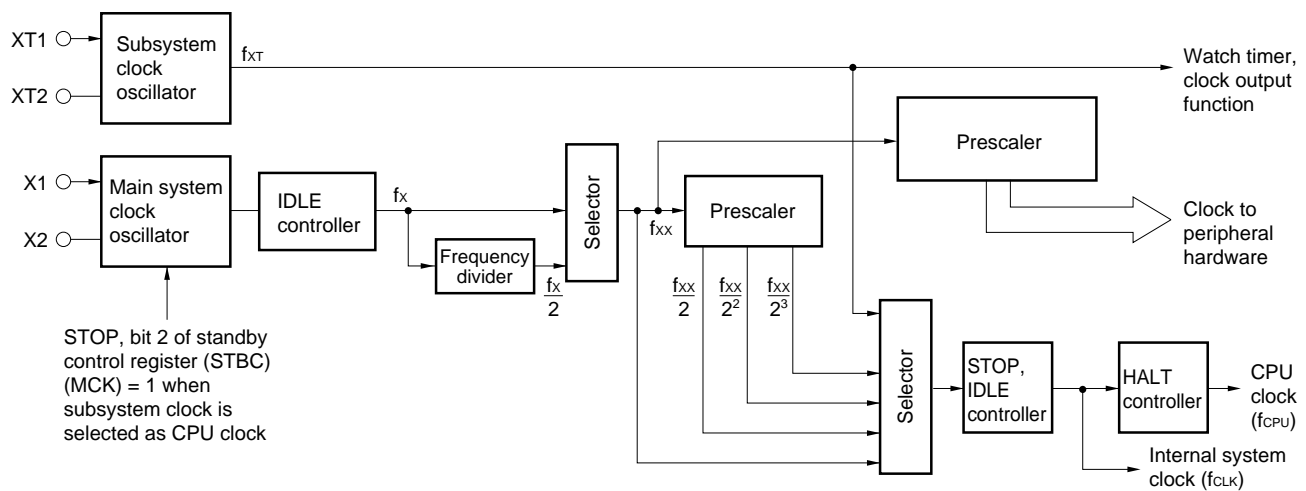



Figure 8-3. Example of Using Main System Clock Oscillator

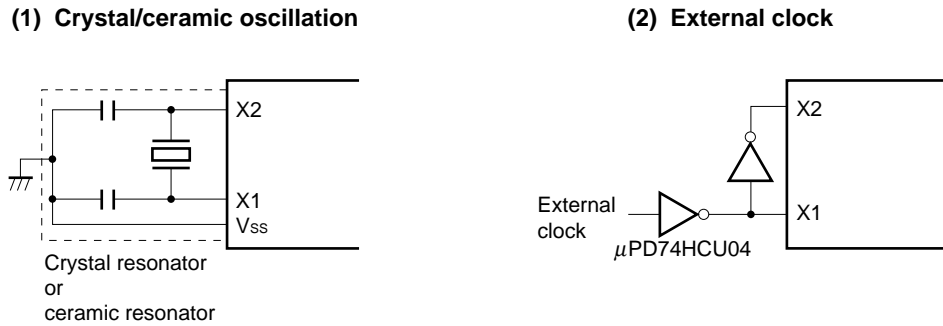
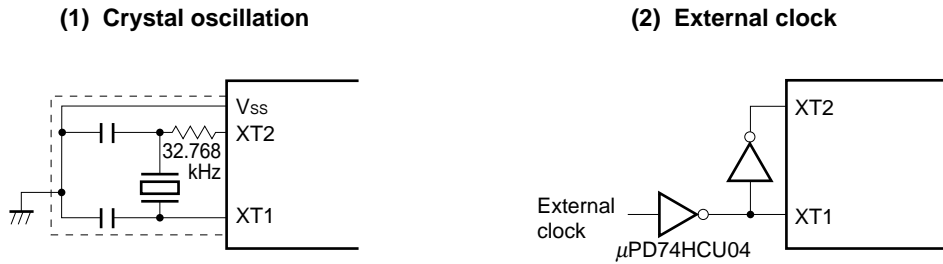

Figure 8-4. Example of Using Subsystem Clock Oscillator



**Caution** When using the main system clock and subsystem clock oscillator, wire as following in the area enclosed by the broken lines in Figures 8-3 and 8-4 to avoid an adverse effect from wiring capacitance.

- Keep the wiring length as short as possible.
- Do not cross the wiring with other signal lines.
- Do not route the wiring near a signal line through which a high fluctuating current flows.
- Always make the ground point of the oscillator capacitor the same potential as V<sub>ss</sub>. Do not ground the capacitor to a ground pattern in which a high current flows.
- Do not fetch signals from the oscillator.

Note that the subsystem clock oscillator is designed as a low-amplitude circuit for reducing current consumption.

### 8.3 Real-Time Output Port

The real-time output function is to transfer data preset in the real-time output buffer register to the output latch as soon as the timer interrupt or external interrupt has occurred in order to output the data to an external device. The pins that output the data to the external device constitute a port called a real-time output port.

Because the real-time output port can output signals without jitter, it is ideal for controlling stepper motors, etc.

Figure 8-5. Block Diagram of Real-Time Output Port

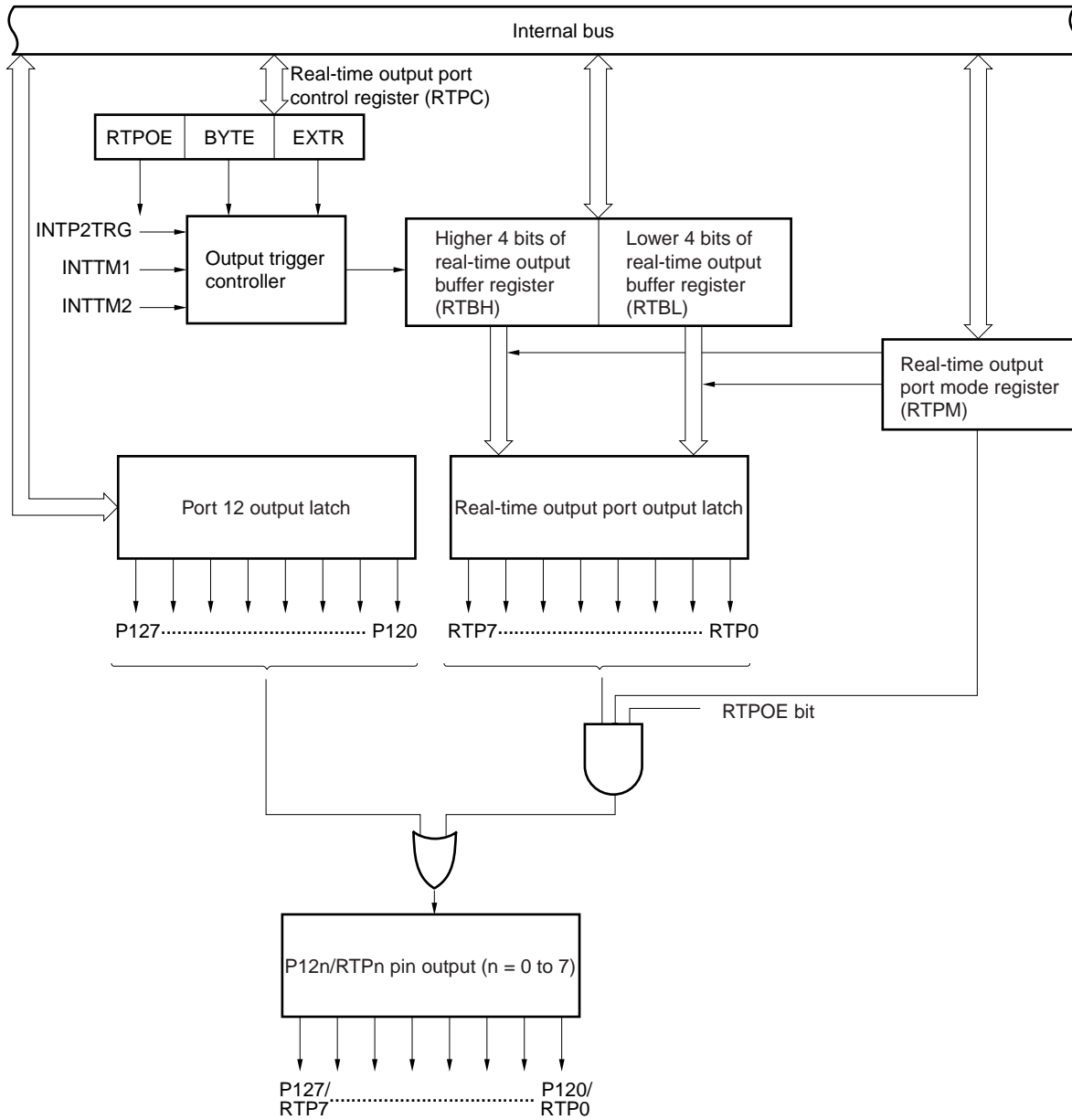

### 8.4 Timer/Event Counter

One unit of 16-bit timer/event counters and six units of 8-bit timer/event counters are provided.

Because a total of eight interrupt requests are supported, these timer/event counters can be used as eight units of timers/counters.

**Table 8-2. Operations of Timer/Event Counters**

Item		Name	16-Bit	8-Bit	8-Bit	8-Bit	8-Bit	8-Bit	8-Bit
			Timer/Event Counter	Timer/Event Counter 1	Timer/Event Counter 2	Timer/Event Counter 5	Timer/Event Counter 6	Timer/Event Counter 7	Timer/Event Counter 8
Count width	8 bits		—	√	√	√	√	√	√
	16 bits		√	√		√		√	
Operation mode	Interval timer		1 ch	1 ch	1 ch	1 ch	1 ch	1 ch	1 ch
	External event counter		√	√	√	√	√	√	√
Function	Timer output		1 ch	1 ch	1 ch	1 ch	1 ch	1 ch	1 ch
	PPG output		√	—	—	—	—	—	—
	PWM output		—	√	√	√	√	√	√
	Square wave output		√	√	√	√	√	√	√
	One-shot pulse output		√	—	—	—	—	—	—
	Pulse width measurement		2 inputs	—	—	—	—	—	—
	Number of interrupt requests		2	1	1	1	1	1	1

Figure 8-6. Block Diagram of Timer/Event Counters

16-bit timer/event counter

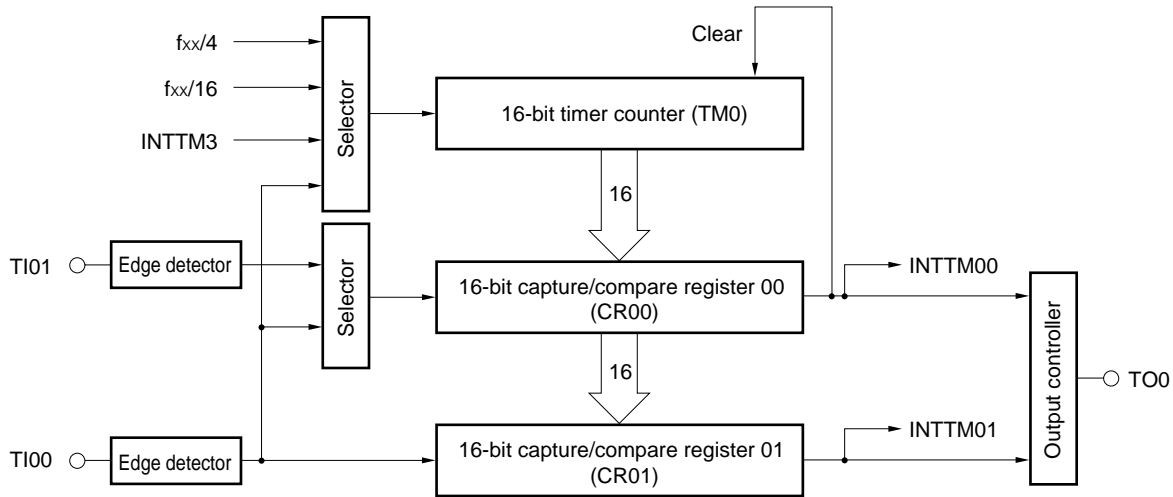

8-bit timer/event counter 1, 5, 7

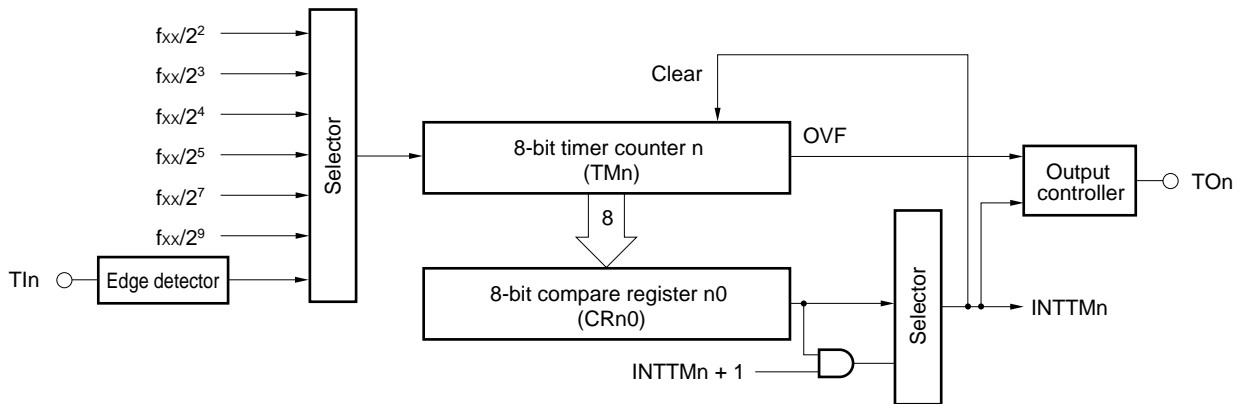

- Remarks 1.  $n = 1, 5, 7$
- 2. OVF: Overflow flag

8-bit timer/event counter 2, 6, 8

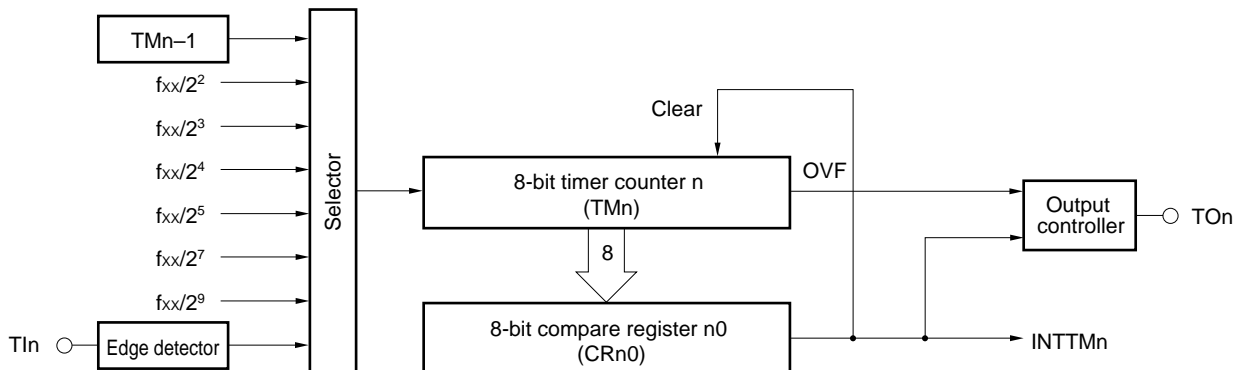

- Remarks 1.  $n = 2, 6, 8$
- 2. OVF: Overflow flag

### 8.5 A/D Converter

An A/D converter converts an analog input variable into a digital signal. This microcontroller is provided with an A/D converter with a resolution of 8 bits and 8 channels (ANI0 through ANI7).

This A/D converter is of successive approximation type and the result of conversion is stored in the 8-bit A/D conversion result register (ADCR).

The A/D converter can be started in the following two ways:

- Hardware start  
Conversion is started by trigger input (P03).
- Software start  
Conversion is started by setting the A/D converter mode register (ADM).

One analog input channel is selected from ANI0 through ANI7 for A/D conversion. When A/D conversion is started by means of hardware start, conversion is stopped after it has been completed. When conversion is started by means of software start, A/D conversion is repeatedly executed, and each time conversion has been completed, an interrupt request (INTAD) is generated.

Figure 8-7. A/D Converter Block Diagram

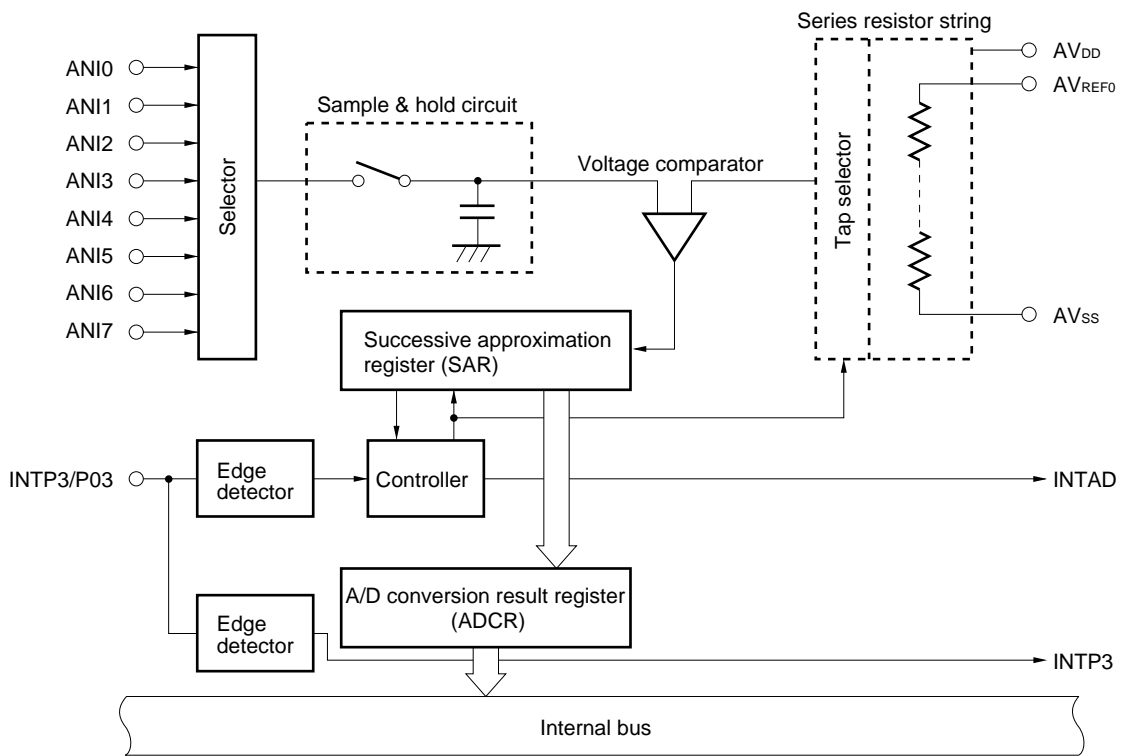



### 8.7 Serial Interfaces

Three independent serial interface channels are provided.

- Asynchronous serial interface (UART)/3-wire serial I/O (IOE) × 2
- Clocked serial interface (CSI) × 1
  - 3-wire serial I/O (IOE)
  - I<sup>2</sup>C bus interface (I<sup>2</sup>C) (μPD784218Y Subseries only)

Therefore, communication with an external system and local communication within the system can be simultaneously executed (refer to **Figure 8-9**).

**Figure 8-9. Example of Serial Interface**

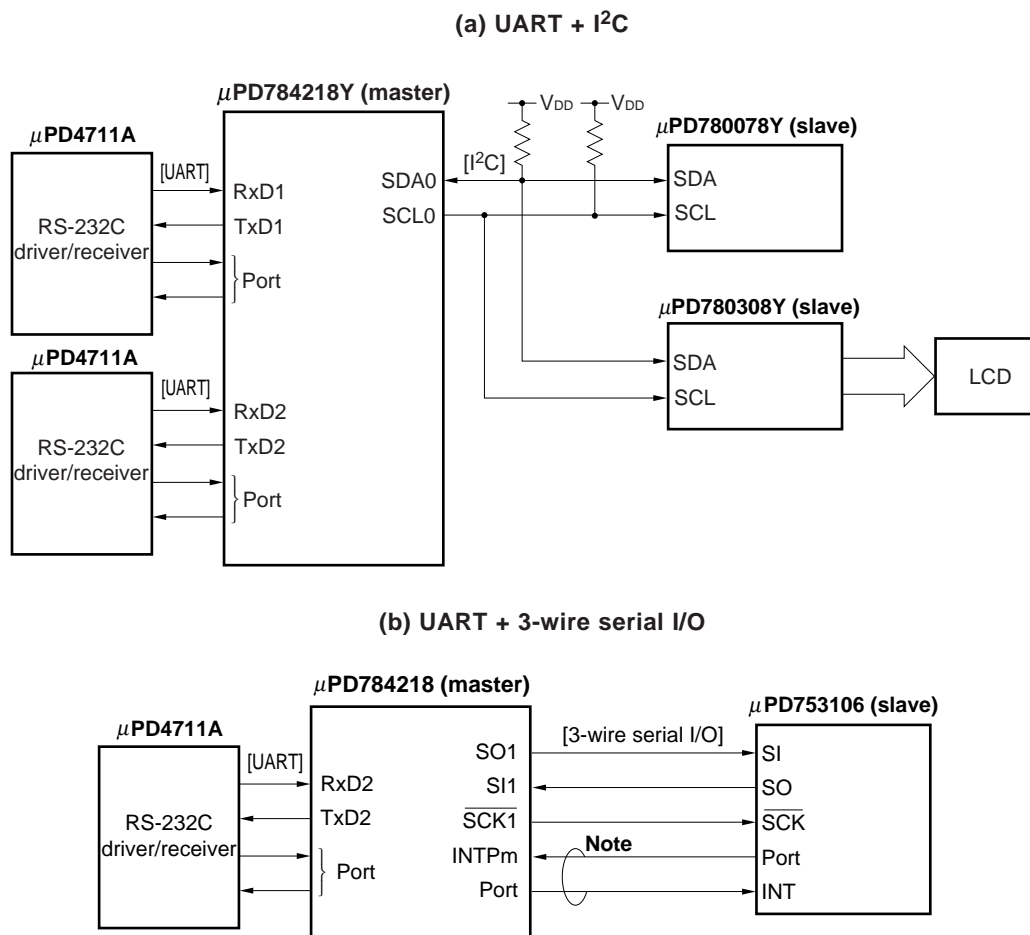

**Note** Handshake line

**8.7.1 Asynchronous serial interface/3-wire serial I/O (UART/IOE)**

Two channels of serial interfaces for which an asynchronous serial interface mode and 3-wire serial I/O mode can be selected are provided.

**(1) Asynchronous serial interface mode**

In this mode, data of 1 byte following the start bit is transmitted or received.  
 Because an on-chip baud rate generator is provided, a wide range of baud rates can be set.  
 Moreover, the clock input to the ASCK pin can be divided to define a baud rate.  
 When the baud rate generator is used, a baud rate conforming to the MIDI standard (31.25 kbps) can also be obtained.

★ **Figure 8-10. Block Diagram When in Asynchronous Serial Interface Mode**

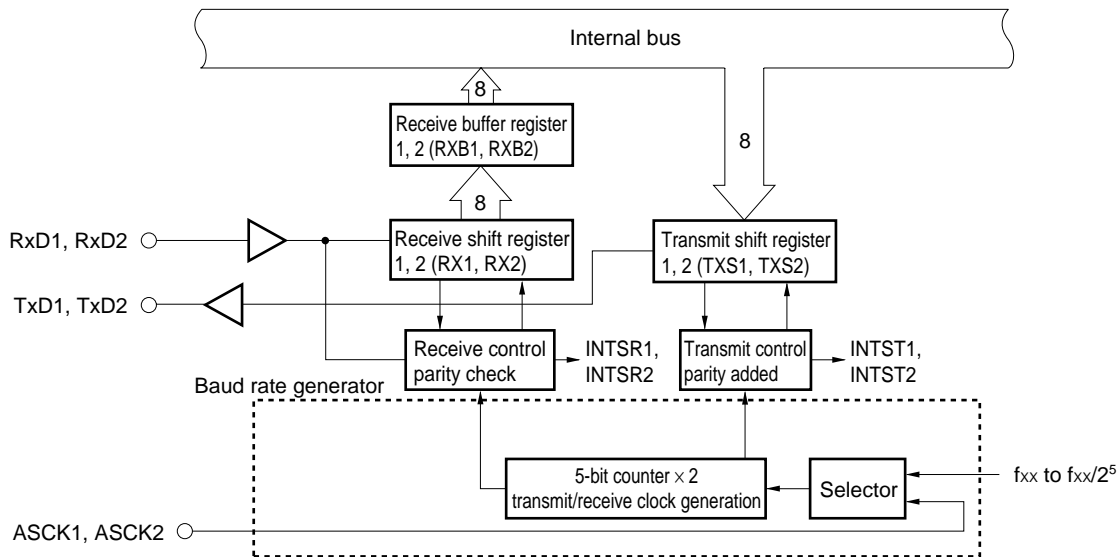



**(2) 3-wire serial I/O mode**

In this mode, the master device starts transfer by making the serial clock active and transfers 1-byte data in synchronization with this clock.

This mode is used to communicate with a device having the conventional clocked serial interface. Basically, communication is established by using three lines: serial clocks ( $\overline{SCK1}$  and  $\overline{SCK2}$ ), serial data inputs (SI1 and SI2), and serial data outputs (SO1 and SO2). To connect two or more devices, a handshake line is necessary.

★

**Figure 8-11. Block Diagram When in 3-Wire Serial I/O Mode**

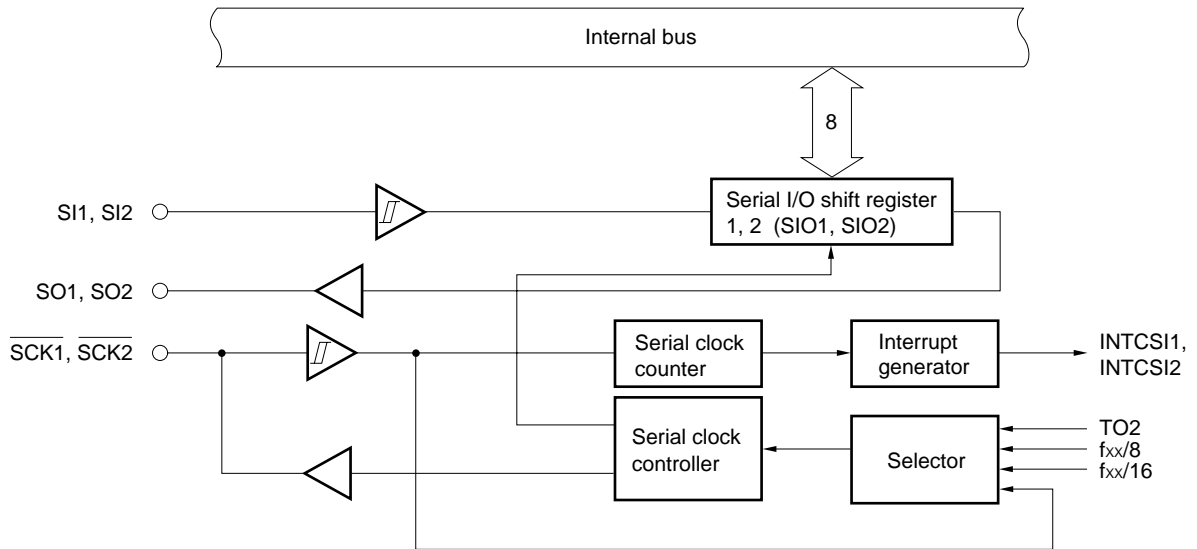

**8.7.2 Clocked serial interface (CSI)**

In this mode, the master device starts transfer by making the serial clock active and transfers 1-byte data in synchronization with this clock.

**(1) 3-wire serial I/O mode**

This mode is to communicate with devices having the conventional clocked serial interface. Basically, communication is established in this mode with three lines: one serial clock ( $\overline{SCK0}$ ) and two serial data (SI0 and SO0) lines. Generally, a handshake line is necessary to check the reception status.

**Figure 8-12. Block Diagram When in 3-Wire Serial I/O Mode**

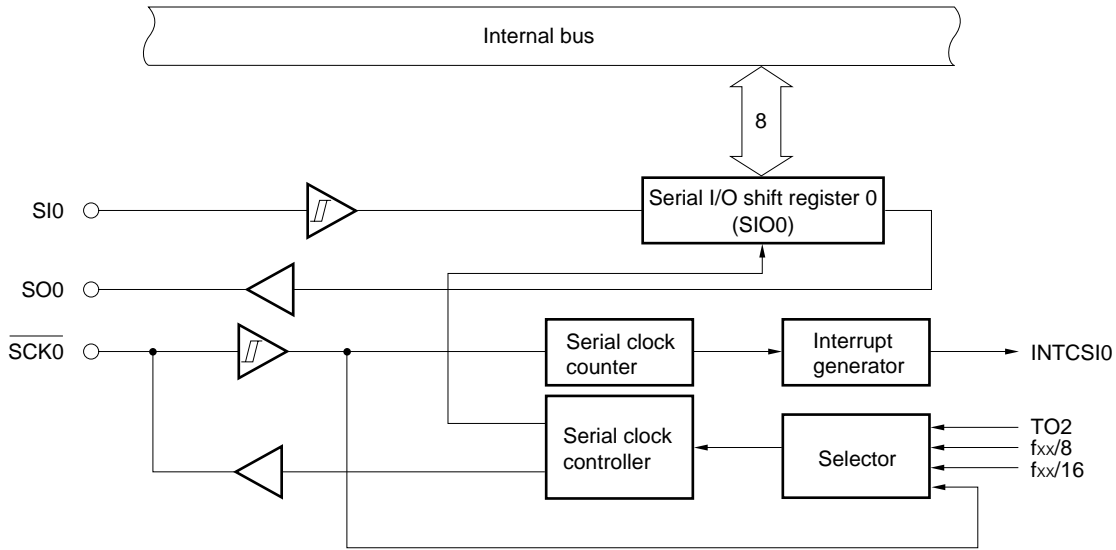

**(2) I<sup>2</sup>C bus (Inter IC) bus mode (multi-master supporting)**

This mode is for communication with devices conforming to the I<sup>2</sup>C bus format. This mode is for transferring 8-bit data between two or more devices by using two lines: a serial clock (SCL0) and a serial data bus (SDA0). During transfer, a "start condition", "data", and "stop condition" can be output onto the serial data bus. During reception, this data is automatically detected by hardware.

Figure 8-13. Block Diagram of I<sup>2</sup>C Bus Mode

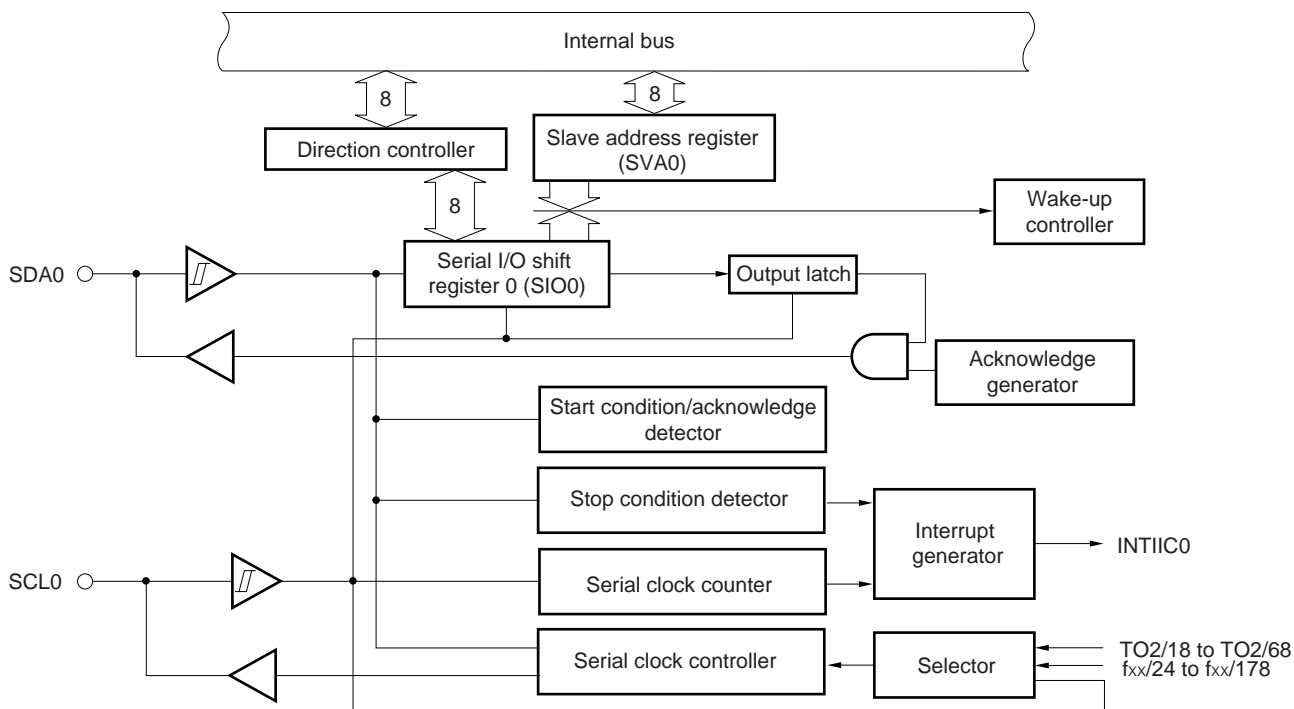

**8.8 Clock Output Function**

Clocks of the following frequencies can be output as clock output.

- 97.7 kHz/195 kHz/391 kHz/781 kHz/1.56 MHz/3.13 MHz/6.25 MHz/12.5 MHz (@ 12.5 MHz operation with main system clock)
- 32.768 kHz (@ 32.768 kHz operation with subsystem clock)

Figure 8-14. Block Diagram of Clock Output Function

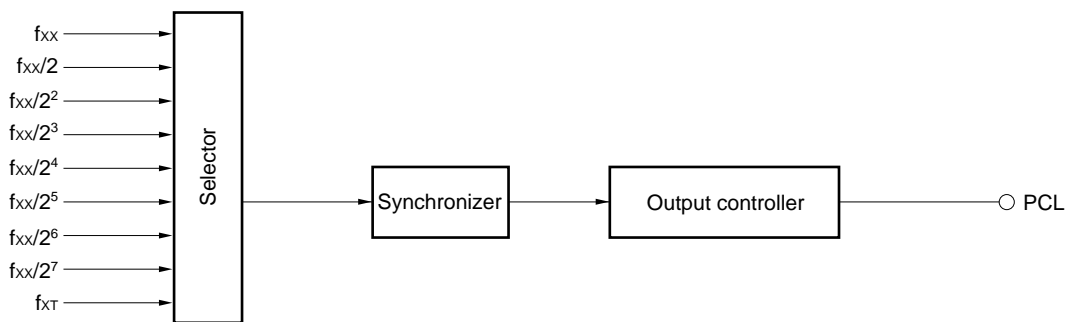

### 8.9 Buzzer Output Function

Clocks of the following frequencies can be output as buzzer output.

- 1.5 kHz/3.1 kHz/6.1 kHz/12.2 kHz (@ 12.5 MHz operation with main system clock)

Figure 8-15. Block Diagram of Buzzer Output Function

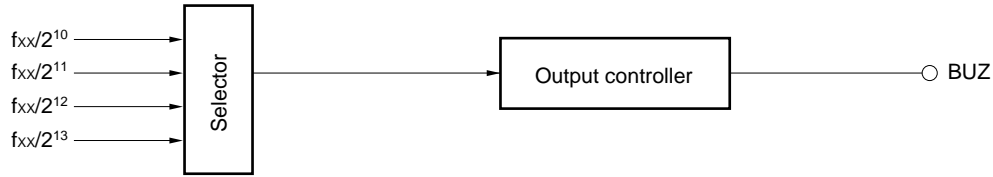

### 8.10 Edge Detection Function

The interrupt input pins (INTP0, INTP1, NMI/INTP2, INTP3 through INTP6) are used not only to input interrupt requests but also to input trigger signals to the internal hardware units. Because these pins operate at an edge of the input signal, they have a function to detect an edge. Moreover, a noise reduction function is also provided to prevent erroneous detection due to noise.

Pin Name	Detectable Edge	Noise Reduction
NMI	Either or both of rising and falling edges	By analog delay
INTP0 to INTP6		

### 8.11 Watch Timer

The watch timer has the following functions:

- Watch timer
- Interval timer

The watch timer and interval timer functions can be used at the same time.

#### (1) Watch timer

The watch timer sets the WTIF flag of the interrupt control register (WTIC) at time intervals of 0.5 seconds using the 32.768 kHz subsystem clock.

#### (2) Interval timer

The interval timer generates an interrupt request (INTTM3) at preset time intervals.

Figure 8-16. Watch Timer Block Diagram

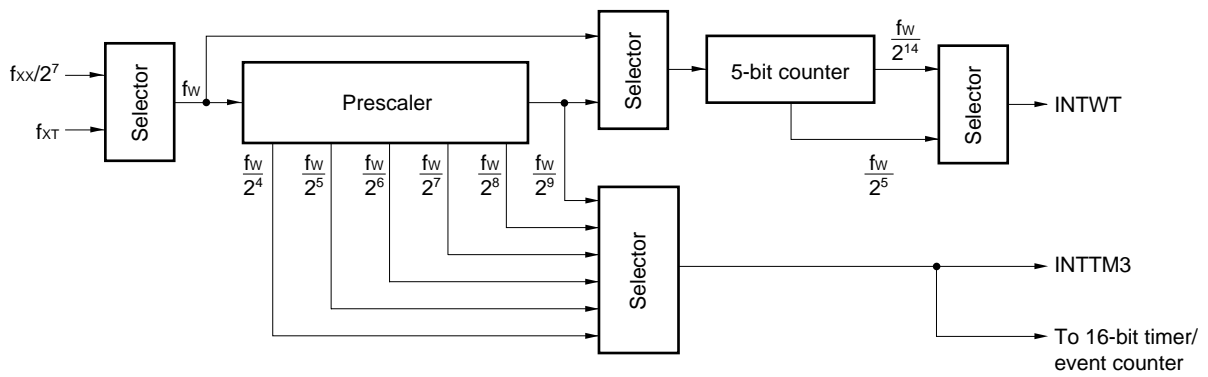

**8.12 Watchdog Timer**

A watchdog timer is provided to detect a CPU runaway. This watchdog timer generates a non-maskable or maskable interrupt unless it is cleared by software within a specified interval time. Once enabled to operate, the watchdog timer cannot be stopped by software. Whether the interrupt by the watchdog timer or the interrupt input from the NMI pin takes precedence can be specified.

Figure 8-17. Watchdog Timer Block Diagram

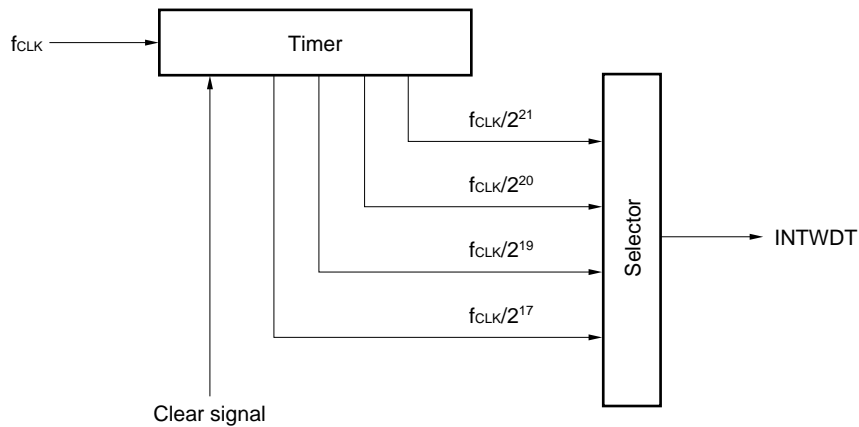

**Remark** fCLK: Internal system clock (fxx to fxx/8)

### 9. INTERRUPT FUNCTION

The three types of servicing in response to an interrupt request shown in Table 9-1 can be selected by program.

**Table 9-1. Servicing of Interrupt Request**

Servicing Mode	Servicing Means	Servicing	Contents of PC and PSW
Vectored interrupt	Software	Branches and executes servicing routine (servicing is arbitrary)	Saves to and restores from stack
Context switching		Automatically switches register bank, branches and executes servicing routine (servicing is arbitrary)	Saves to or restores from fixed area in register bank
Macro service	Firmware	Executes data transfer between memory and I/O (servicing is fixed)	Retained

#### 9.1 Interrupt Sources

Table 9-2 shows the interrupt sources available. As shown, interrupts are generated by 29 sources, execution of the BRK instruction, BRKCS instruction, or an operand error.

The priority of interrupt servicing can be set to four levels, so that nesting can be controlled during interrupt servicing, and so that which of the two or more interrupts that simultaneously occur should be serviced first can be decided. When the macro service function is used, however, nesting always proceeds (i.e., is not held pending).

The default priority is the priority (fixed) of the service that is performed if two or more interrupt requests, having the same priority, are simultaneously generated (refer to **Table 9-2**).

**Table 9-2. Interrupt Sources (1/2)**

Type	Default Priority	Source		Internal/ External	Macro Service
		Name	Trigger		
Software	—	BRK instruction	Instruction execution	—	—
		BRKCS instruction	Instruction execution		
		Operand error	If result of exclusive OR between operands byte and byte is not FFH when MOV STBC, #byte instruction, MOV WDM, #byte instruction, or LOCATION instruction is executed		
Non-maskable	—	NMI	Pin input edge detection	External	—
		INTWDT	Overflow of watchdog timer	Internal	
Maskable	0 (highest)	INTWDTM	Overflow of watchdog timer	Internal	√
	1	INTP0	Pin input edge detection	External	
	2	INTP1			
	3	INTP2			
	4	INTP3			
	5	INTP4			
	6	INTP5			
	7	INTP6			
	8	INTIIC0	End of I <sup>2</sup> C bus transfer by CS10	Internal	
		INTCSI0	End of 3-wire transfer by CS10		
9	INTSER1	Occurrence of UART reception error in ASI1			

Table 9-2. Interrupt Sources (2/2)

Type	Default Priority	Source		Internal/ External	Macro Service
		Name	Trigger		
Maskable	10	INTSR1	End of UART reception by ASI1	Internal	√
		INTCSI1	End of 3-wire transfer by CSI1		
	11	INTST1	End of UART transmission by ASI1		
	12	INTSER2	Occurrence of UART reception error in ASI2		
	13	INTSR2	End of UART reception by ASI2		
		INTCSI2	End of 3-wire transfer by CSI2		
	14	INTST2	End of UART transmission by ASI2		
	15	INTTM3	Reference time interval signal from watch timer		
	16	INTTM00	Signal indicating coincidence between 16-bit timer counter and capture/compare register (CR00)		
	17	INTTM01	Signal indicating coincidence between 16-bit timer counter and capture/compare register (CR01)		
	18	INTTM1	Occurrence of coincidence signal of 8-bit timer/event counter 1		
	19	INTTM2	Occurrence of coincidence signal of 8-bit timer/event counter 2		
	20	INTAD	End of conversion by A/D converter		
	21	INTTM5	Occurrence of coincidence signal of 8-bit timer/event counter 5		
	22	INTTM6	Occurrence of coincidence signal of 8-bit timer/event counter 6		
	23	INTTM7	Occurrence of coincidence signal of 8-bit timer/event counter 7		
	24	INTTM8	Occurrence of coincidence signal of 8-bit timer/event counter 8		
25	INTWT	Overflow of watch timer	External		
26 (lowest)	INTKR	Detection of falling edge of port 8			

Remarks 1. ASI: Asynchronous Serial Interface

CSI: Clocked Serial Interface

★

2. Two watchdog timer interrupt sources, non-maskable interrupt (INTWDT) and maskable interrupt (INTWDTM), are available and only one of those can be selected.

### 9.2 Vectored Interrupt

Execution branches to a servicing routine by using the memory contents of a vector table address corresponding to the interrupt source as the address of the branch destination.

So that the CPU performs interrupt servicing, the following operations are performed:

- On branching: Saves the status of the CPU (contents of PC and PSW) to stack
- On returning: Restores the status of the CPU (contents of PC and PSW) from stack

To return to the main routine from an interrupt service routine, the RETI instruction is used. The branch destination address is in a range of 0 to FFFFH.

**Table 9-3. Vector Table Address**

Interrupt Source	Vector Table Address	Interrupt Source	Vector Table Address
BRK instruction	003EH	INTST1	001CH
TRAP0 (operand error)	003CH	INTSER2	001EH
NMI	0002H	INSR2	0020H
INTWDT (non-maskable)	0004H	INTCSI2	
INTWDTM (maskable)	0006H	INTST2	0022H
INTP0	0008H	INTTM3	0024H
INTP1	000AH	INTTM00	0026H
INTP2	000CH	INTTM01	0028H
INTP3	000EH	INTTM1	002AH
INTP4	0010H	INTTM2	002CH
INTP5	0012H	INTAD	002EH
INTP6	0014H	INTTM5	0030H
INTIIC0	0016H	INTTM6	0032H
INTCSI0		INTTM7	0034H
INTSER0	0018H	INTTM8	0036H
INTSR1	001AH	INTWT	0038H
INTCSI1		INTKR	003AH



### 9.3 Context Switching

When an interrupt request is generated or when the BRKCS instruction is executed, a predetermined register bank is selected by hardware. Context switching is a function that branches execution to a vector address stored in advance in the register bank, and stacks the current contents of the program counter (PC) and program status word (PSW) to the register bank.

The branch address is in a range of 0 to FFFFH.

Figure 9-1. Context Switching Operation When Interrupt Request Is Generated

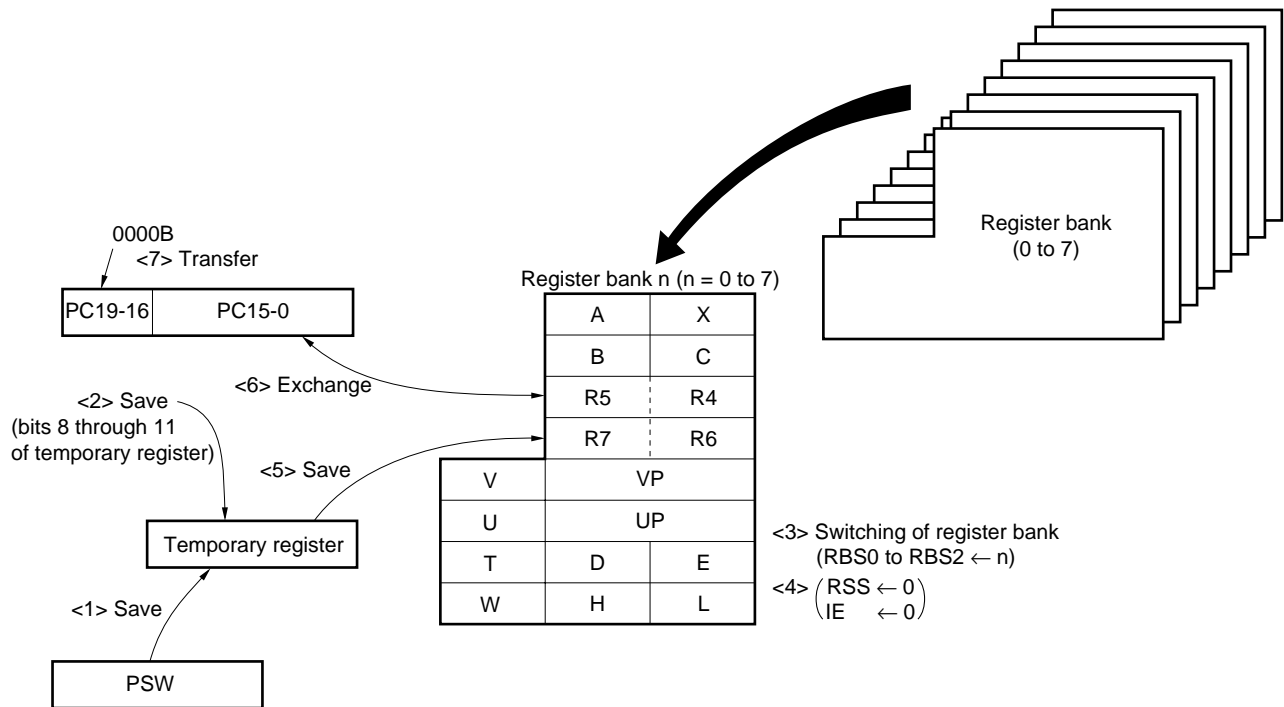

### 9.4 Macro Service

This function is to transfer data between memory and a special function register (SFR) without intervention by the CPU. A macro service controller accesses the memory and SFR in the same transfer cycle and directly transfers data without loading it.

Because this function does not save or restore the status of the CPU, or load data, data can be transferred at high speeds.

Figure 9-2. Macro Service

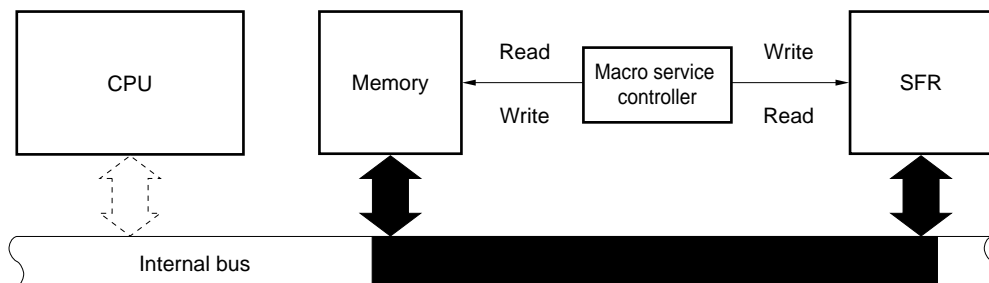

9.5 Application Example of Macro Service

(1) Serial interface transmission

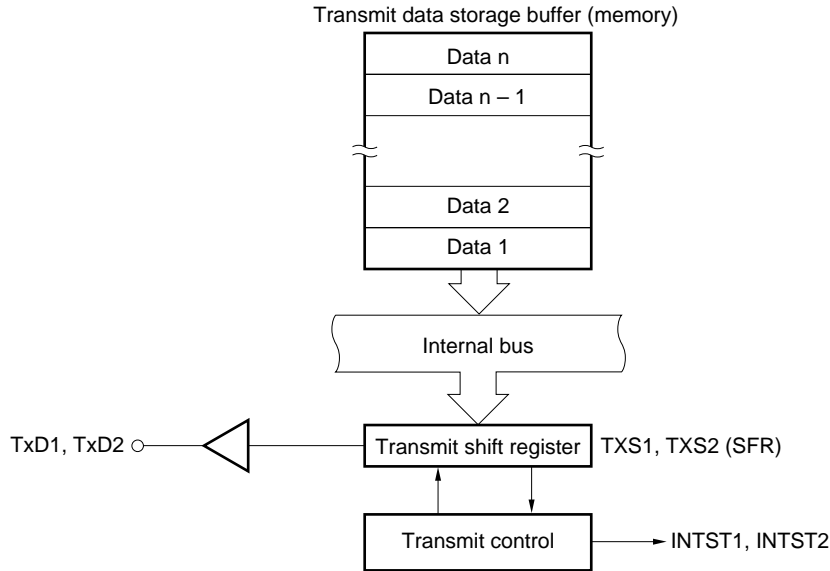

Each time macro service requests INTST1 and INTST2 are generated, the next transmit data is transferred from memory to TXS1 and TXS2. When data n (last byte) has been transferred to TXS1 and TXS2 (when the transmit data storage buffer has become empty), vectored interrupt requests INTST1 and INTST2 are generated.

(2) Serial interface reception

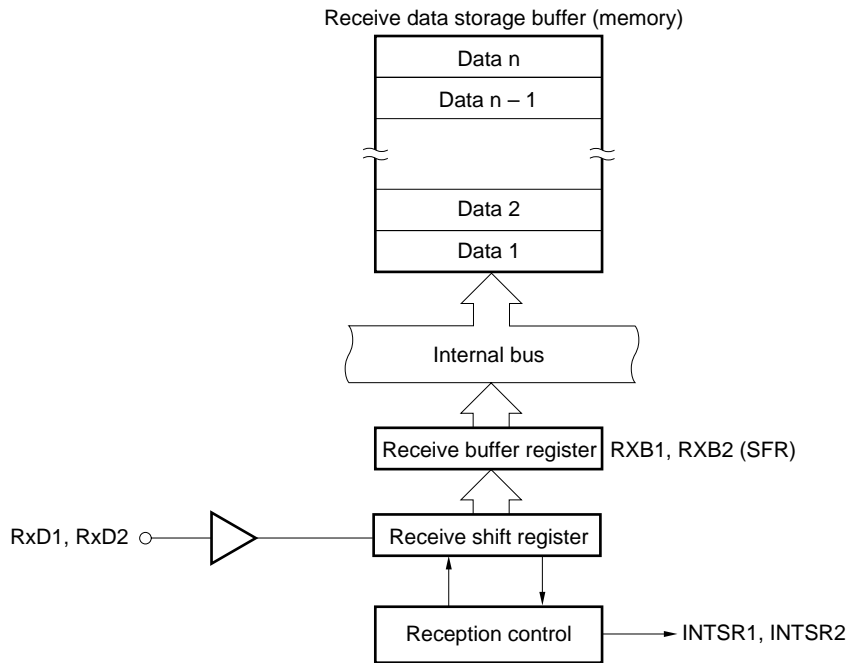

Each time macro service requests INTSR1 and INTSR2 are generated, the receive data is transferred from RXB1 and RXB2 to memory. When data n (last byte) has been transferred to memory (when the receive data storage buffer has become full), vectored interrupt requests INTSR1 and INTSR2 are generated.

10. LOCAL BUS INTERFACE

The local bus interface can connect an external memory or I/O (memory mapped I/O) and support a memory space of 1 MB (refer to Figure 10-1).

Figure 10-1. Example of Local Bus Interface

(a) Multiplexed bus mode

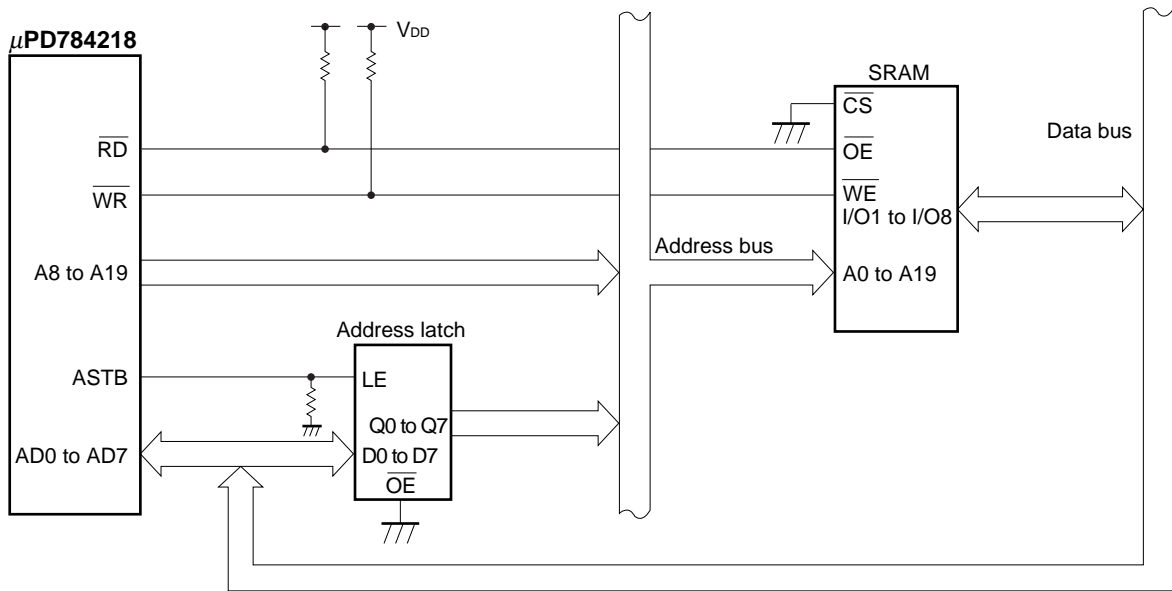

(b) Separate bus mode

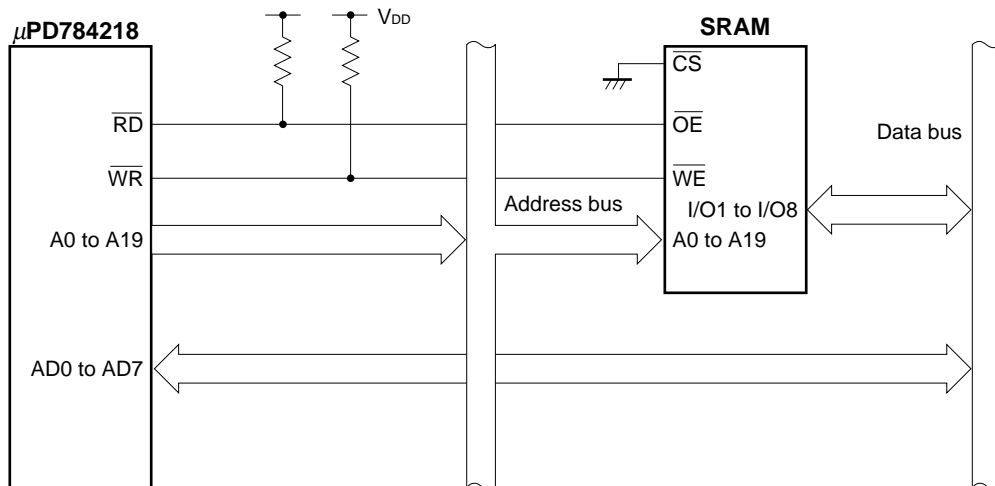

### 10.1 Memory Expansion

External program memory and data memory can be connected in two stages: 256 KB and 1 MB.

To connect the external memory, ports 4 through 6 and port 8 are used.

The external memory can be connected in the following two modes:

- Multiplexed bus mode: The external memory is connected by using a time-division address/data bus. The number of ports used when the external memory is connected can be reduced in this mode.
- Separate bus mode: The external memory is connected by using an address bus and data bus independent of each other. Because an external latch circuit is not necessary, this mode is useful for reducing the number of components and mounting area on the printed wiring board.

### 10.2 Programmable Wait

Wait state(s) can be inserted to the memory space (00000H through FFFFFH) while the  $\overline{RD}$  and  $\overline{WR}$  signals are active.

In addition, there is an address wait function that extends the active period of the ASTB signal to gain the address decode time.

### 10.3 External Access Status Function

An active-low external access status signal is output from the P37/EXA pin. This signal informs other devices that are connected with external buses of the external access status, prohibits other devices from outputting data to an external bus, and enables receive operations.

The external access status signal is output during external accessing.

## 11. STANDBY FUNCTION

This function is to reduce the power consumption of the chip, and can be used in the following modes:

- HALT mode: Stops supply of the operating clock to the CPU. This mode is used in combination with the normal operation mode for intermittent operation to reduce the average power consumption.
- IDLE mode: Stops the entire system with the oscillator continuing operation. The power consumption in this mode is close to that in the STOP mode. However, the time required to restore the normal program operation from this mode is almost the same as that from the HALT mode.
- STOP mode: Stops the main system clock and thereby stops all the internal operations of the chip. Consequently, the power consumption is minimized with only leakage current flowing.
- Low power consumption mode: The main system clock is stopped with the subsystem clock used as the system clock. The CPU can operate on the subsystem clock to reduce the current consumption.
- Low power consumption HALT mode: This is a standby function in the low power consumption mode and stops the operation clock of the CPU, to reduce the power consumption of the entire system.
- Low power consumption IDLE mode: This is a standby function in the low power consumption mode and stops the entire system except the oscillator, to reduce the power consumption of the entire system.

These modes are programmable.

The macro service can be started from the HALT mode or low power consumption HALT mode. After macro service processing is executed, the system returns to the HALT mode again.

The transition of the standby status is shown in Figure 11-1.

★

Figure 11-1. Standby Function State Transition

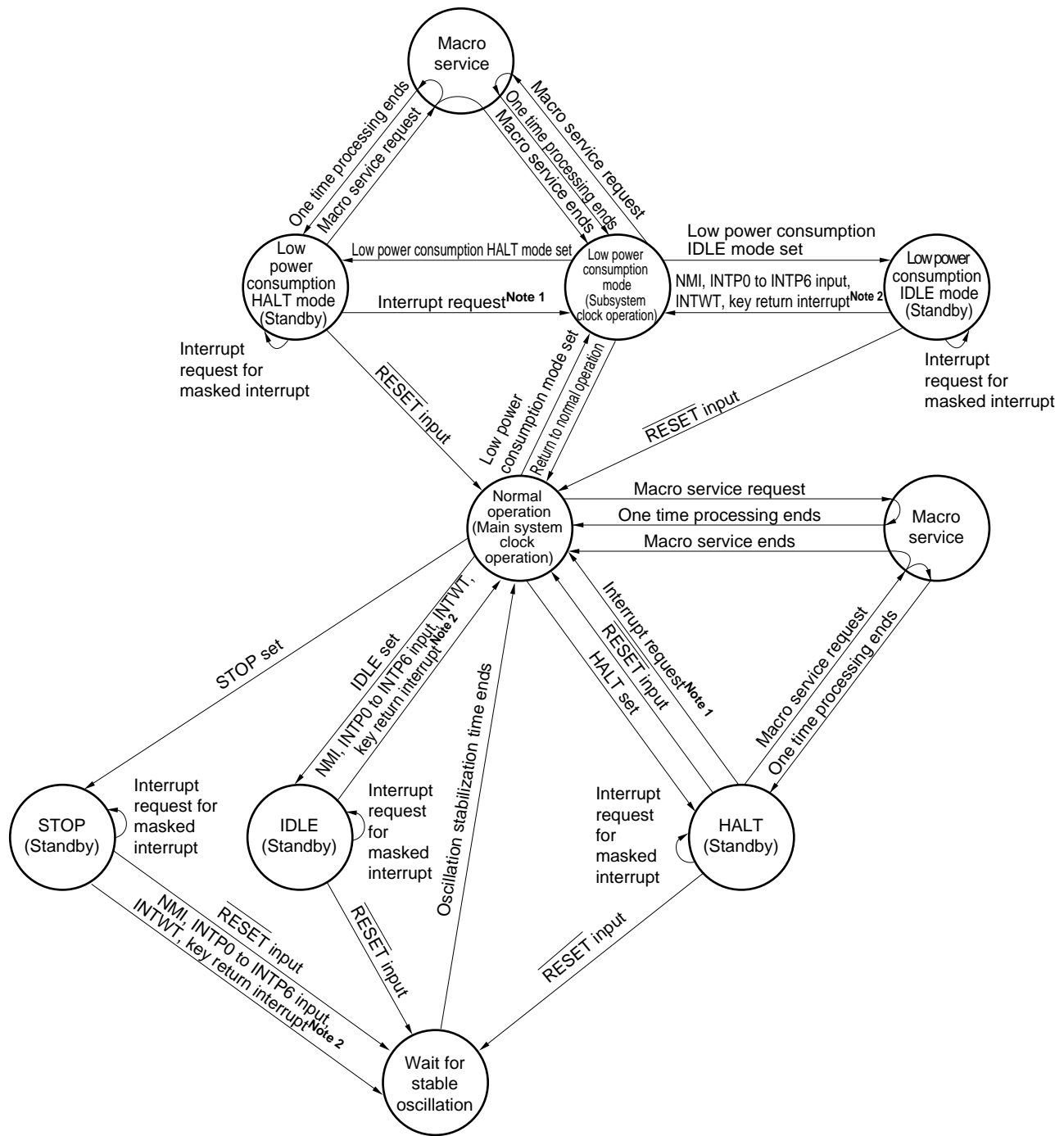

- Notes**
1. Only unmasked interrupt requests
  2. Only unmasked INTP0 to INTP6, INTWT, key return interrupt (P80 to P87)

**Remark** NMI is valid only for an external input.  
The watchdog timer cannot be used for the release of standby (HALT mode/STOP mode/IDLE mode).

### 12. RESET FUNCTION

When a low-level signal is input to the  $\overline{\text{RESET}}$  pin, the system is reset, and each hardware unit is initialized (reset). During the reset period, oscillation of the main system clock is unconditionally stopped. Consequently, the current consumption of the entire system can be reduced.

When the  $\overline{\text{RESET}}$  signal goes high, the reset status is cleared, the oscillation stabilization time (84.0 ms at 12.5 MHz operation) elapses, the contents of the reset vector table are set to the program counter (PC), execution branches to an address set to the PC, and program execution is started from that branch address. Therefore, the program can be reset and started from any address.

**Figure 12-1. Oscillation of Main System Clock During Reset Period**

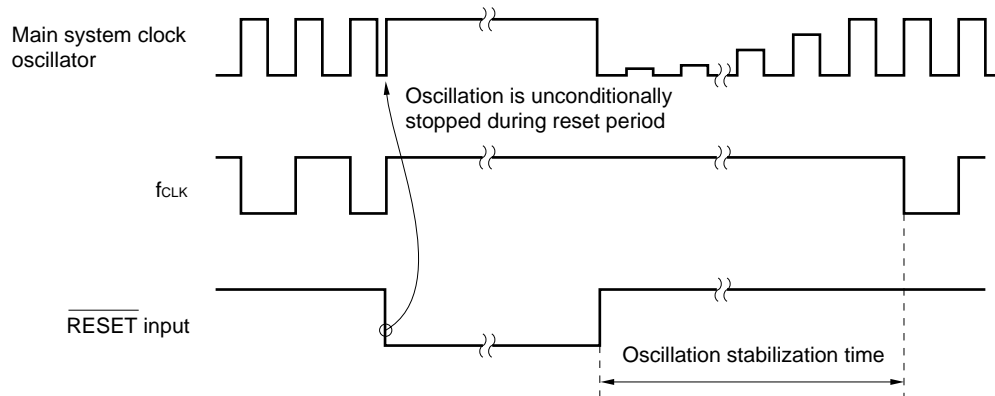

The  $\overline{\text{RESET}}$  input pin has an analog delay noise eliminator to prevent malfunctioning due to noise.

**Figure 12-2. Acknowledgement of Reset Signal**

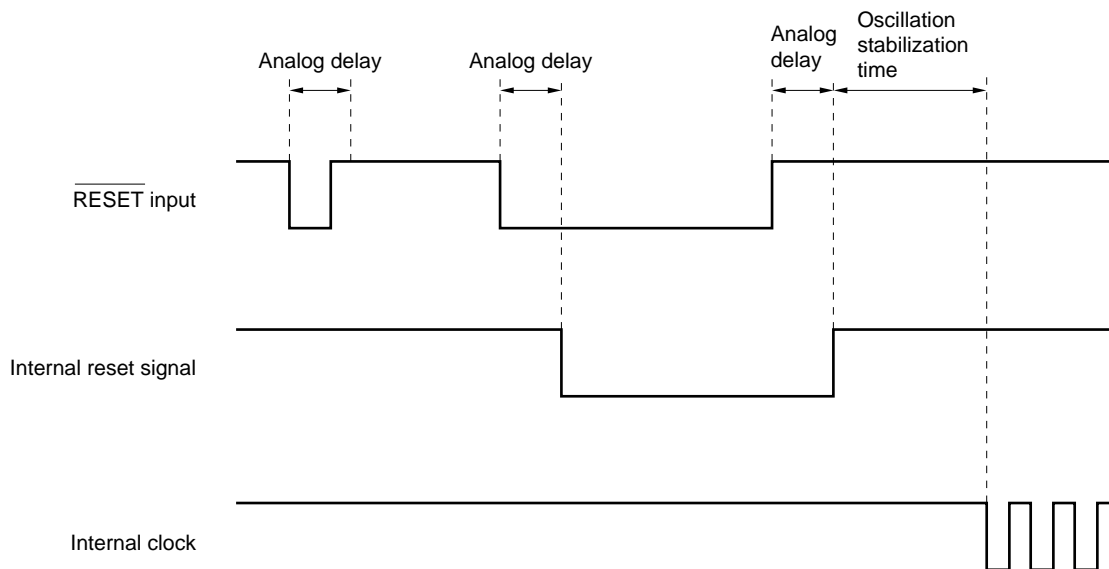

### 13. ROM CORRECTION

ROM correction is a function for avoiding execution of a part of a program in the internal ROM that needs to be corrected by executing the corrected program, which is stored in the internal RAM.

By using this function, instruction bugs found in the internal ROM can be avoided and the program flow can be changed.

Up to four combinations between source internal ROM (program) and target RAM sections are available for the ROM correction.

Figure 13-1. ROM Correction Block Diagram

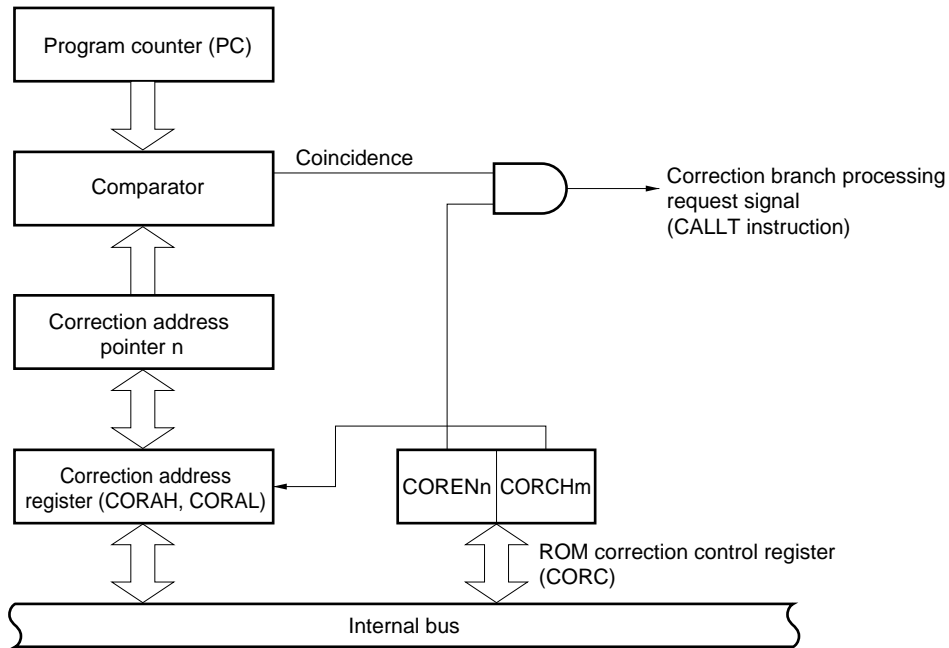

**Remark** n = 0 to 3, m = 0, 1



14. INSTRUCTION SET

- (1) 8-bit instructions (The instructions in parentheses are combinations realized by describing A as r)  
 MOV, XCH, ADD, ADDC, SUB, SUBC, AND, OR, XOR, CMP, MULU, DIVUW, INC, DEC, ROR, ROL, RORC, ROLC, SHR, SHL, ROR4, ROL4, DBNZ, PUSH, POP, MOV, XCHM, CMPME, CMPMNE, CMPMNC, CMPMC, MOVBK, XCHBK, CMPBKE, CMPBKNE, CMPBKNC, CMPBK

Table 14-1. Instruction List by 8-Bit Addressing

Second Operand First Operand	#byte	A	r r'	saddr saddr'	sfr	!addr16 !!addr24	mem [saddrp] [%saddrg]	r3 PSWL PSWH	[WHL+] [WHL-]	n	None <sup>Note 2</sup>
A	(MOV) ADD <sup>Note 1</sup>	(MOV) (XCH) (ADD) <sup>Note 1</sup>	MOV XCH (ADD) <sup>Note 1</sup>	(MOV) <sup>Note 6</sup> (XCH) <sup>Note 6</sup> (ADD) <sup>Notes 1,6</sup>	MOV (XCH) (ADD) <sup>Note 1</sup>	(MOV) (XCH) ADD <sup>Note 1</sup>	MOV XCH ADD <sup>Note 1</sup>	MOV	(MOV) (XCH) (ADD) <sup>Note 1</sup>		
r	MOV ADD <sup>Note 1</sup>	(MOV) (XCH) (ADD) <sup>Note 1</sup>	MOV XCH ADD <sup>Note 1</sup>	MOV XCH ADD <sup>Note 1</sup>	MOV XCH ADD <sup>Note 1</sup>	MOV XCH				ROR <sup>Note 3</sup>	MULU DIVUW INC DEC
saddr	MOV ADD <sup>Note 1</sup>	(MOV) <sup>Note 6</sup> (ADD) <sup>Note 1</sup>	MOV ADD <sup>Note 1</sup>	MOV XCH ADD <sup>Note 1</sup>							INC DEC DBNZ
sfr	MOV ADD <sup>Note 1</sup>	MOV (ADD) <sup>Note 1</sup>	MOV ADD <sup>Note 1</sup>								PUSH POP
!addr16 !!addr24	MOV	(MOV) ADD <sup>Note 1</sup>	MOV								
mem [saddrp] [%saddrg]		MOV ADD <sup>Note 1</sup>									
mem3											ROR4 ROL4
r3 PSWL PSWH	MOV	MOV									
B, C											DBNZ
STBC, WDM	MOV										
[TDE+] [TDE-]		(MOV) (ADD) <sup>Note 1</sup> MOV <sup>Note 4</sup>							MOVBK <sup>Note 5</sup>		

- Notes**
1. The operands of ADDC, SUB, SUBC, AND, OR, XOR, and CMP are the same as those of ADD.
  2. Either the second operand is not used, or the second operand is not an operand address.
  3. The operands of ROL, RORC, ROLC, SHR, and SHL are the same as those of ROR.
  4. The operands of XCHM, CMPME, CMPMNE, CMPMNC, and CMPMC are the same as those of MOV.
  5. The operands of XCHBK, CMPBKE, CMPBKNE, CMPBKNC, and CMPBK are the same as those of MOVBK.
  6. The code length of some instructions having saddr2 as saddr in this combination is short.

(2) 16-bit instructions (The instructions in parentheses are combinations realized by describing AX as rp)

MOVW, XCHW, ADDW, SUBW, CMPW, MULW, DIVUX, INCW, DECW, SHRW, SHLW, PUSH, POP, ADDWG, SUBWG, PUSHU, POPU, MOVTLBW, MACW, MACSW, SACW

Table 14-2. Instruction List by 16-Bit Addressing

Second Operand First Operand	#word	AX	rp rp'	saddrp saddrp'	sfrp	!addr16 !!addr24	mem [saddrp] [%saddrg]	[WHL+]	byte	n	None <sup>Note 2</sup>
AX	(MOVW) ADDW <sup>Note 1</sup>	(MOVW) (XCHW) (ADD) <sup>Note 1</sup>	(MOVW) (XCHW) (ADDW) <sup>Note 1</sup>	(MOVW) <sup>Note 3</sup> (XCHW) <sup>Note 3</sup> (ADDW) <sup>Notes 1, 3</sup>	MOVW (XCHW) (ADDW) <sup>Note 1</sup>	(MOVW) XCHW	MOVW XCHW	(MOVW) (XCHW)			
rp	MOVW ADDW <sup>Note 1</sup> (ADDW) <sup>Note 1</sup>	(MOVW) (XCHW) (ADDW) <sup>Note 1</sup>	MOVW XCHW ADDW <sup>Note 1</sup>	MOVW XCHW ADDW <sup>Note 1</sup>	MOVW XCHW ADDW <sup>Note 1</sup>	MOVW				SHRW SHLW	MULW <sup>Note 4</sup> INCW DECW
saddrp	MOVW ADDW <sup>Note 1</sup>	(MOVW) <sup>Note 3</sup> (ADDW) <sup>Note 1</sup>	MOVW ADDW <sup>Note 1</sup>	MOVW XCHW ADDW <sup>Note 1</sup>							INCW DECW
sfrp	MOVW ADDW <sup>Note 1</sup>	MOVW (ADDW) <sup>Note 1</sup>	MOVW ADDW <sup>Note 1</sup>								PUSH POP
!addr16 !!addr24	MOVW	(MOVW)	MOVW						MOVTLBW		
mem [saddrp] [%saddrg]		MOVW									
PSW											PUSH POP
SP	ADDWG SUBWG										
post											PUSH POP PUSHU POPU
[TDE+]		(MOVW)						SACW			
byte											MACW MACSW

- Notes**
1. The operands of SUBW and CMPW are the same as those of ADDW.
  2. Either the second operand is not used, or the second operand is not an operand address.
  3. The code length of some instructions having saddrp2 as saddrp in this combination is short.
  4. The operands of MULW and DIVUX are the same as those of MULW.

(3) 24-bit instructions (The instructions in parentheses are combinations realized by describing WHL as rg)

MOVG, ADDG, SUBG, INCG, DECG, PUSH, POP

Table 14-3. Instruction List by 24-Bit Addressing

Second Operand First Operand	#imm24	WHL	rg rg'	saddrg	!!addr24	mem1	[%saddrg]	SP	None Note
WHL	(MOVG) (ADDG) (SUBG)	(MOVG) (ADDG) (SUBG)	(MOVG) (ADDG) (SUBG)	(MOVG) ADDG SUBG	(MOVG)	MOVG	MOVG	MOVG	
rg	MOVG ADDG SUBG	(MOVG) (ADDG) (SUBG)	MOVG ADDG SUBG	MOVG	MOVG				INCG DECG PUSH POP
saddrg		(MOVG)	MOVG						
!!addr24		(MOVG)	MOVG						
mem1		MOVG							
[%saddrg]		MOVG							
SP	MOVG	MOVG							INCG DECG

**Note** Either the second operand is not used, or the second operand is not an operand address.

(4) Bit manipulation instructions

MOV1, AND1, OR1, XOR1, SET1, CLR1, NOT1, BT, BF, BTCLR, BFSET

Table 14-4. Instruction List by Bit Manipulation Instruction Addressing

Second Operand First Operand	CY	saddr.bit sfr.bit A.bit X.bit PSWL.bit PSWH.bit mem2.bit !addr16.bit !!addr24.bit	/saddr.bit /sfr. bit /A.bit /X.bit /PSWL.bit /PSWH.bit /mem2.bit /!addr16.bit /!!addr24.bit	None <sup>Note</sup>
CY		MOV1 AND1 OR1 XOR1	AND1 OR1	NOT1 SET1 CLR1
saddr.bit sfr.bit A.bit X.bit PSWL.bit PSWH.bit mem2.bit !addr16.bit !!addr24.bit	MOV1			NOT1 SET1 CLR1 BF BT BTCLR BFSET

**Note** Either the second operand is not used, or the second operand is not an operand address.

**(5) Call and return/branch instructions**

CALL, CALLF, CALLT, BRK, RET, RETI, RETB, RETCS, RETCSB, BRKCS, BR, BNZ, BNE, BZ, BE, BNC, BNL, BC, BL, BNV, BPO, BV, BPE, BP, BN, BLT, BGE, BLE, BGT, BNH, BH, BF, BT, BTCLR, BFSET, DBNZ

**Table 14-5. Instruction List by Call and Return/Branch Instruction Addressing**

Operand of Instruction Address	\$addr20	!addr20	!addr16	!!addr20	rp	rg	[rp]	[rg]	!addr11	[addr5]	RBn	None
Basic instruction	BC BR	CALL BR	CALL BR RETCS RETCSB	CALL BR	CALL BR	CALL BR	CALL BR	CALL BR	CALLF	CALLF	BRKCS	BRK RET RETI RETB
Compound instruction	BF BT BTCLR BFSET DBNZ											

**Note** The operands of BNZ, BNE, BZ, BE, BNC, BNL, BL, BNV, BPO, BV, BPE, BP, BN, BLT, BGE, BLE, BGT, BNH, and BH are the same as those of BC.

**(6) Other instructions**

ADJBA, ADJBS, CVTBW, LOCATION, SEL, NOT, EI, DI, SWRS

15. ELECTRICAL SPECIFICATIONS

Absolute Maximum Ratings (T<sub>A</sub> = 25°C)

Parameter	Symbol	Conditions	Ratings	Unit
Supply voltage	V <sub>DD</sub>		-0.3 to +6.5	V
	AV <sub>DD</sub>		-0.3 to V <sub>DD</sub> + 0.3	V
	AV <sub>SS</sub>		-0.3 to V <sub>SS</sub> + 0.3	V
	AV <sub>REF0</sub>	A/D converter reference voltage input	-0.3 to V <sub>DD</sub> + 0.3	V
	AV <sub>REF1</sub>	D/A converter reference voltage input	-0.3 to V <sub>DD</sub> + 0.3	V
Input voltage	V <sub>I1</sub>	Other than P90 to P95	-0.3 to V <sub>DD</sub> + 0.3	V
	V <sub>I2</sub>	P90 to P95      N-ch open drain	-0.3 to +12	V
Analog input voltage	V <sub>AN</sub>	Analog input pin	AV <sub>SS</sub> - 0.3 to AV <sub>REF0</sub> + 0.3	V
Output voltage	V <sub>O</sub>		-0.3 to V <sub>DD</sub> + 0.3	V
Output current, low	I <sub>OL</sub>	Per pin	15	mA
		Total of P2, P4 to P8	75	mA
		Total of P0, P3, P9, P10, P12, P13	75	mA
Output current, high	I <sub>OH</sub>	Per pin	-10	mA
		Total of P2, P4 to P8	-50	mA
		Total of P0, P3, P9, P10, P12, P13	-50	mA
Operating ambient temperature	T <sub>A</sub>		-40 to +85	°C
Storage temperature	T <sub>stg</sub>		-65 to +150	°C

**Caution** Product quality may suffer if the absolute maximum rating is exceeded even momentarily for any parameter. That is, the absolute maximum ratings are rated values at which the product is on the verge of suffering physical damage, and therefore the product must be used under conditions that ensure that the absolute maximum ratings are not exceeded.

**Operating Conditions**

- Operating ambient temperature (T<sub>A</sub>): -40 to +85°C
- Power supply voltage and clock cycle time: see **Figure 15-1**

**Figure 15-1. Power Supply Voltage and Clock Cycle Time**

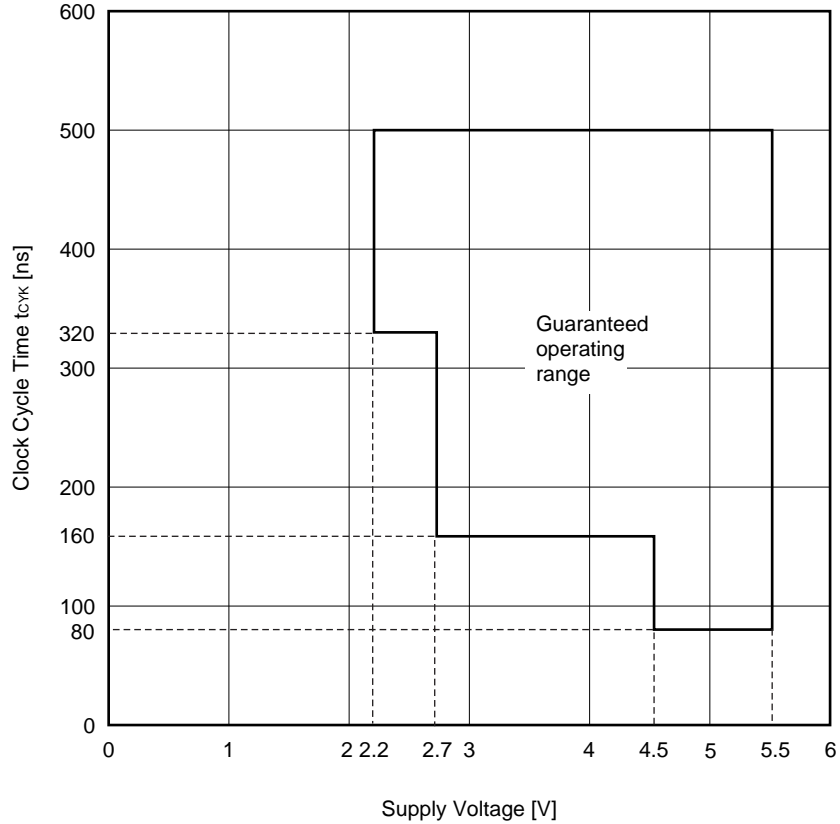

**CAPACITANCE (T<sub>A</sub> = 25°C, V<sub>DD</sub> = V<sub>SS</sub> = 0 V)**

Parameter	Symbol	Conditions	MIN.	TYP.	MAX.	Unit	
Input capacitance	C <sub>i</sub>	f = 1 MHz Unmeasured pins returned to 0 V.	Other than Port 9			15	pF
			Port 9			20	pF
Output capacitance	C <sub>o</sub>	f = 1 MHz Unmeasured pins returned to 0 V.	Other than Port 9			15	pF
			Port 9			20	pF
I/O capacitance	C <sub>io</sub>	f = 1 MHz Unmeasured pins returned to 0 V.	Other than Port 9			15	pF
			Port 9			20	pF

Main System Clock Oscillator Characteristics (T<sub>A</sub> = -40 to +85°C)

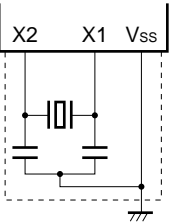
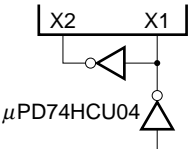
Resonator	Recommended Circuit	Parameter	Test Conditions	MIN.	TYP.	MAX.	Unit
Ceramic resonator or crystal resonator		Oscillation frequency (f <sub>x</sub> )	4.5 V ≤ V <sub>DD</sub> ≤ 5.5 V	2		12.5	MHz
			2.7 V ≤ V <sub>DD</sub> < 4.5 V	2		6.25	
			2.2 V ≤ V <sub>DD</sub> < 2.7 V	2		3	
External clock		X1 input frequency (f <sub>x</sub> )	4.5 V ≤ V <sub>DD</sub> ≤ 5.5 V	2		25	MHz
			2.7 V ≤ V <sub>DD</sub> < 4.5 V	2		12.5	
			2.2 V ≤ V <sub>DD</sub> < 2.7 V	2		6.25	
		X1 input high-/low-level width (t <sub>wXH</sub> , t <sub>wXL</sub> )		15		250	ns
		X1 input rise/fall time (t <sub>xR</sub> , t <sub>xF</sub> )	4.5 V ≤ V <sub>DD</sub> ≤ 5.5 V	0		5	ns
			2.7 V ≤ V <sub>DD</sub> < 4.5 V	0		10	
2.2 V ≤ V <sub>DD</sub> < 2.7 V	0			20			

**Cautions 1.** When using the main system clock oscillator, wire as follows in the area enclosed by the broken lines in the above figures to avoid an adverse effect from wiring capacitance.

- Keep the wiring length as short as possible.
- Do not cross the wiring with the other signal lines.
- Do not route the wiring near a signal line through which a high fluctuating current flows.
- Always make the ground point of the oscillator capacitor the same potential as V<sub>ss</sub>.
- Do not ground the capacitor to a ground pattern through which a high current flows.
- Do not fetch signals from the oscillator.

**2.** When the main system clock is stopped and the device is operating on the subsystem clock, wait until the oscillation stabilization time has been secured by the program before switching back to the main system clock.

★ **Remark** For the resonator selection and oscillator constant, customers are required to either evaluate the oscillation themselves or apply to the resonator manufacturer for evaluation.

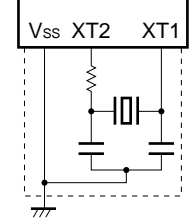
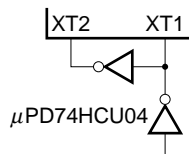

Subsystem Clock Oscillator Characteristics (T<sub>A</sub> = -40 to +85°C)

Resonator	Recommended Circuit	Parameter	Test Conditions	MIN.	TYP.	MAX.	Unit
Crystal resonator		Oscillation frequency (f <sub>XT</sub> )		32	32.768	35	kHz
		Oscillation stabilization time <sup>Note</sup>	4.5 V ≤ V <sub>DD</sub> ≤ 5.5 V		1.2	2	s
			2.2 V ≤ V <sub>DD</sub> < 4.5 V			10	
External clock		XT1 input frequency (f <sub>XT</sub> )		32		35	kHz
		XT1 input high-/low-level width (t <sub>XTH</sub> , t <sub>XTL</sub> )		5		15	μs

**Note** Time required to stabilize oscillation after the power supply voltage (V<sub>DD</sub>) is applied.

**Cautions** 1. When using the subsystem clock oscillator, wire as follows in the area enclosed by the broken lines in the above figures to avoid an adverse effect from wiring capacitance.

- Keep the wiring length as short as possible.
- Do not cross the wiring with the other signal lines.
- Do not route the wiring near a signal line through which a high fluctuating current flows.
- Always make the ground point of the oscillator capacitor the same potential as V<sub>SS</sub>.
- Do not ground the capacitor to a ground pattern through which a high current flows.
- Do not fetch signals from the oscillator.

2. When the main system clock is stopped and the device is operating on the subsystem clock, wait until the oscillation stabilization time has been secured by the program before switching back to the main system clock.

★ **Remark** For the resonator selection and oscillator constant, customers are required to either evaluate the oscillation themselves or apply to the resonator manufacturer for evaluation.

DC Characteristics (T<sub>A</sub> = -40 to +85°C, V<sub>DD</sub> = AV<sub>DD</sub> = 2.2 to 5.5 V, V<sub>SS</sub> = AV<sub>SS</sub> = 0 V) (1/2)

Parameter	Symbol	Condition	MIN.	TYP.	MAX.	Unit
Input voltage, low	V <sub>IL1</sub>	<b>Note 1</b>	0		0.3V <sub>DD</sub>	V
	V <sub>IL2</sub>	Total for P00 to P06, P20, P22, P33, P34, P70, P72, P100 to P103, RESET	0		0.2V <sub>DD</sub>	V
	V <sub>IL3</sub>	P90 to P95 (N-ch open drain)	0		0.3V <sub>DD</sub>	V
	V <sub>IL4</sub>	Total for P10 to P17, P130, P131	0		0.3V <sub>DD</sub>	V
	V <sub>IL5</sub>	Total for X1, X2, XT1, XT2	0		0.2V <sub>DD</sub>	V
	V <sub>IL6</sub>	P25, P27	0		0.3V <sub>DD</sub>	V
Input voltage, high	V <sub>IH1</sub>	<b>Note 1</b>	0.7V <sub>DD</sub>		V <sub>DD</sub>	V
	V <sub>IH2</sub>	Total for P00 to P06, P20, P22, P33, P34, P70, P72, P100 to P103, RESET	0.8V <sub>DD</sub>		V <sub>DD</sub>	V
	V <sub>IH3</sub>	P90 to P95 (N-ch open drain)	0.7V <sub>DD</sub>		12	V
	V <sub>IH4</sub>	Total for P10 to P17, P130, P131	0.7V <sub>DD</sub>		V <sub>DD</sub>	V
	V <sub>IH5</sub>	Total for X1, X2, XT1, XT2	0.8V <sub>DD</sub>		V <sub>DD</sub>	V
	V <sub>IH6</sub>	P25, P27	0.7V <sub>DD</sub>		V <sub>DD</sub>	V
Output voltage, low	V <sub>OL1</sub>	For pins other than P40 to P47, P50 to P57, P90 to P95 I <sub>OL</sub> = 1.6 mA <b>Note 2</b>	V <sub>DD</sub> = 4.5 to 5.5 V		0.4	V
		Total for P40 to P47, P50 to P57 I <sub>OL</sub> = 8 mA <b>Note 2</b>	V <sub>DD</sub> = 4.5 to 5.5 V		1.0	V
		P90 to P95 I <sub>OL</sub> = 15 mA <b>Note 2</b>	V <sub>DD</sub> = 4.5 to 5.5 V	0.8	2.0	V
	V <sub>OL2</sub>	I <sub>OL</sub> = 400 μA <b>Note 2</b>			0.5	V
Output voltage, high	V <sub>OH1</sub>	I <sub>OH</sub> = -1 mA <b>Note 2</b>	V <sub>DD</sub> = 4.5 to 5.5 V	V <sub>DD</sub> - 1.0		V
		I <sub>OL</sub> = -100 μA <b>Note 2</b>		V <sub>DD</sub> - 0.5		V
Input leakage current, low	I <sub>LIL1</sub>	V <sub>IN</sub> = 0 V	Except X1, X2, XT1, XT2		-3	μA
	I <sub>LIL2</sub>			X1, X2, XT1, XT2		-20
Input leakage current, high	I <sub>LIH1</sub>	V <sub>IN</sub> = V <sub>DD</sub>	Except X1, X2, XT1, XT2		3	μA
	I <sub>LIH2</sub>			X1, X2, XT1, XT2		20
Output leakage current, low	I <sub>LOL1</sub>	V <sub>OUT</sub> = 0 V			-3	μA
Output leakage current, high	I <sub>LOH1</sub>	V <sub>OUT</sub> = V <sub>DD</sub>			3	μA

**Notes** 1. P21, P23, P24, P26, P30 to P32, P35 to P37, P40 to P47, P50 to P57, P60 to P67, P71, P80 to P87, P120 to P127

2. Per pin

DC Characteristics (T<sub>A</sub> = -40 to +85°C, V<sub>DD</sub> = AV<sub>DD</sub> = 2.2 to 5.5 V, V<sub>SS</sub> = AV<sub>SS</sub> = 0 V) (2/2)

Parameter	Symbol	Condition	MIN.	TYP.	MAX.	Unit	
Supply current	I <sub>DD1</sub>	Operation mode	f <sub>XX</sub> = 12.5 MHz		20	40	mA
			f <sub>XX</sub> = 6 MHz, 2.7 V ≤ V <sub>DD</sub> ≤ 3.3 V		8	17	mA
			f <sub>XX</sub> = 3 MHz, 2.2 V ≤ V <sub>DD</sub> < 2.7 V		4	8	mA
	I <sub>DD2</sub>	HALT mode	f <sub>XX</sub> = 12.5 MHz		8	20	mA
			f <sub>XX</sub> = 6 MHz, 2.7 V ≤ V <sub>DD</sub> ≤ 3.3 V		3	8	mA
			f <sub>XX</sub> = 3 MHz, 2.2 V ≤ V <sub>DD</sub> < 2.7 V		1.3	3.5	mA
	I <sub>DD3</sub>	IDLE mode	f <sub>XX</sub> = 12.5 MHz		1	2.5	mA
			f <sub>XX</sub> = 6 MHz, 2.7 V ≤ V <sub>DD</sub> ≤ 3.3 V		0.5	1.3	mA
			f <sub>XX</sub> = 3 MHz, 2.2 V ≤ V <sub>DD</sub> < 2.7 V		0.3	0.9	mA
	I <sub>DD4</sub>	Operation mode <sup>Note</sup>	f <sub>XX</sub> = 32 kHz		100	200	μA
			f <sub>XX</sub> = 32 kHz, 2.7 V ≤ V <sub>DD</sub> ≤ 3.3 V		55	110	μA
			f <sub>XX</sub> = 32 kHz, 2.2 V ≤ V <sub>DD</sub> < 2.7 V		50	100	μA
	I <sub>DD5</sub>	HALT mode <sup>Note</sup>	f <sub>XX</sub> = 32 kHz		80	160	μA
			f <sub>XX</sub> = 32 kHz, 2.7 V ≤ V <sub>DD</sub> ≤ 3.3 V		40	80	μA
			f <sub>XX</sub> = 32 kHz, 2.2 V ≤ V <sub>DD</sub> < 2.7 V		35	70	μA
I <sub>DD6</sub>	IDLE mode <sup>Note</sup>	f <sub>XX</sub> = 32 kHz		75	150	μA	
		f <sub>XX</sub> = 32 kHz, 2.7 V ≤ V <sub>DD</sub> ≤ 3.3 V		35	70	μA	
		f <sub>XX</sub> = 32 kHz, 2.2 V ≤ V <sub>DD</sub> < 2.7 V		30	60	μA	
Data retention voltage	V <sub>DDDR</sub>	HALT, IDLE modes	2.2		5.5	V	
Data retention current	I <sub>DDDR</sub>	STOP mode	V <sub>DD</sub> = 2.2 V		2	10	μA
			V <sub>DD</sub> = 4.5 to 5.5 V		10	50	μA
Pull-up resistor	R <sub>L</sub>	V <sub>IN</sub> = 0 V	10	30	100	kΩ	

**Note** When main system clock is stopped

**Remark** Unless otherwise specified, the characteristics of alternate-function pins are the same as those of port pins.

AC Characteristics (T<sub>A</sub> = -40 to +85°C, V<sub>DD</sub> = AV<sub>DD</sub> = 2.2 to 5.5 V, V<sub>SS</sub> = AV<sub>SS</sub> = 0 V)

(1) Read/write operation (1/2)

Parameter	Symbol	Conditions	MIN.	TYP.	MAX.	Unit
Cycle time	t <sub>CYK</sub>	4.5 V ≤ V <sub>DD</sub> ≤ 5.5 V	80			ns
		2.7 V ≤ V <sub>DD</sub> < 4.5 V	160			ns
		2.2 V ≤ V <sub>DD</sub> < 2.7 V	320			ns
Address setup time (to ASTB↓)	t <sub>SAST</sub>	V <sub>DD</sub> = 5.0 V	(0.5 + a) T - 11			ns
		V <sub>DD</sub> = 3.0 V	(0.5 + a) T - 15			ns
Address hold time (from ASTB↓)	t <sub>HSTLA</sub>	V <sub>DD</sub> = 5.0 V	0.5T - 19			ns
		V <sub>DD</sub> = 3.0 V	0.5T - 24			ns
ASTB high-level width	t <sub>WSTH</sub>	V <sub>DD</sub> = 5.0 V	(0.5 + a) T - 17			ns
		V <sub>DD</sub> = 3.0 V	(0.5 + a) T - 40			ns
Address hold time (from $\overline{RD}\uparrow$ )	t <sub>HRA</sub>	V <sub>DD</sub> = 5.0 V	0.5T - 14			ns
		V <sub>DD</sub> = 3.0 V	0.5T - 14			ns
Delay time from address to $\overline{RD}\downarrow$	t <sub>DAR</sub>	V <sub>DD</sub> = 5.0 V	(1 + a) T - 24			ns
		V <sub>DD</sub> = 3.0 V	(1 + a) T - 24			ns
Address float time (from $\overline{RD}\downarrow$ )	t <sub>FRA</sub>		0			ns
Data input time from address	t <sub>DAID</sub>	V <sub>DD</sub> = 5.0 V			(2.5 + a + n) T - 37	ns
		V <sub>DD</sub> = 3.0 V			(2.5 + a + n) T - 52	ns
Data input time from ASTB↓	t <sub>DSTID</sub>	V <sub>DD</sub> = 5.0 V			(2 + n) T - 35	ns
		V <sub>DD</sub> = 3.0 V			(2 + n) T - 50	ns
Data input time from $\overline{RD}\downarrow$	t <sub>DRID</sub>	V <sub>DD</sub> = 5.0 V			(1.5 + n) T - 40	ns
		V <sub>DD</sub> = 3.0 V			(1.5 + n) T - 50	ns
Delay time from ASTB↓ to $\overline{RD}\downarrow$	t <sub>DSTR</sub>	V <sub>DD</sub> = 5.0 V	0.5T - 9			ns
		V <sub>DD</sub> = 3.0 V	0.5T - 9			ns
Data hold time (from $\overline{RD}\uparrow$ )	t <sub>HRID</sub>		0			ns
Address active time from $\overline{RD}\uparrow$	t <sub>DRA</sub>	V <sub>DD</sub> = 5.0 V	0.5T - 2			ns
		V <sub>DD</sub> = 3.0 V	0.5T - 12			ns
Delay time from $\overline{RD}\uparrow$ to ASTB↑	t <sub>DRST</sub>	V <sub>DD</sub> = 5.0 V	0.5T - 9			ns
		V <sub>DD</sub> = 3.0 V	0.5T - 9			ns
$\overline{RD}$ low-level width	t <sub>WRL</sub>	V <sub>DD</sub> = 5.0 V	(1.5 + n) T - 25			ns
		V <sub>DD</sub> = 3.0 V	(1.5 + n) T - 30			ns
Delay time from address to $\overline{WR}\downarrow$	t <sub>DAW</sub>	V <sub>DD</sub> = 5.0 V	(1 + a) T - 24			ns
		V <sub>DD</sub> = 3.0 V	(1 + a) T - 24			ns
Address hold time (from $\overline{WR}\uparrow$ )	t <sub>HWA</sub>	V <sub>DD</sub> = 5.0 V	0.5T - 14			ns
		V <sub>DD</sub> = 3.0 V	0.5T - 14			ns
Delay time from ASTB↓ to data output	t <sub>DSTOD</sub>	V <sub>DD</sub> = 5.0 V			0.5T + 15	ns
		V <sub>DD</sub> = 3.0 V			0.5T + 20	ns

**Remark** T: t<sub>CYK</sub> = 1/f<sub>XX</sub> (f<sub>XX</sub>: main system clock frequency)

a: 1 (during address wait), otherwise 0

n: Number of waits (n ≥ 0)

AC Characteristics

(1) Read/write operation (2/2)

Parameter	Symbol	Conditions	MIN.	TYP.	MAX.	Unit
Data output delay time $\overline{WR}\downarrow$	t <sub>DWOD</sub>			10	62	ns
Delay time from $ASTB\downarrow$ to $\overline{WR}\downarrow$	t <sub>DSTW</sub>	V <sub>DD</sub> = 5.0 V	0.5T - 9			ns
		V <sub>DD</sub> = 3.0 V	0.5T - 9			ns
Data setup time (to $\overline{WR}\uparrow$ )	t <sub>SODWR</sub>	V <sub>DD</sub> = 5.0 V	(1.5 + n) T - 20			ns
		V <sub>DD</sub> = 3.0 V	(1.5 + n) T - 25			ns
Data hold time (from $\overline{WR}\uparrow$ )	t <sub>HWOD</sub>	V <sub>DD</sub> = 5.0 V	0.5T - 14			ns
		V <sub>DD</sub> = 3.0 V	0.5T - 14			ns
$ASTB\uparrow$ delay time (from $\overline{WR}\uparrow$ )	t <sub>DWST</sub>	V <sub>DD</sub> = 5.0 V	0.5T - 9			ns
		V <sub>DD</sub> = 3.0 V	0.5T - 9			ns
$\overline{WR}$ low-level width	t <sub>WWL</sub>	V <sub>DD</sub> = 5.0 V	(1.5 + n) T - 25			ns
		V <sub>DD</sub> = 3.0 V	(1.5 + n) T - 30			ns

**Remark** T: t<sub>CYK</sub> = 1/f<sub>XX</sub> (f<sub>XX</sub>: main system clock frequency)

a: 1 (during address wait), otherwise 0

n: Number of waits (n ≥ 0)

AC Characteristics

(2) External wait timing

Parameter	Symbol	Conditions	MIN.	TYP.	MAX.	Unit
Input time from address to $\overline{\text{WAIT}}\downarrow$	$t_{\text{DAWT}}$	$V_{\text{DD}} = 5.0 \text{ V}$			$(2 + a) T - 40$	ns
		$V_{\text{DD}} = 3.0 \text{ V}$			$(2 + a) T - 60$	ns
Input time from $\text{ASTB}\downarrow$ to $\overline{\text{WAIT}}\downarrow$	$t_{\text{DSTWT}}$	$V_{\text{DD}} = 5.0 \text{ V}$			$1.5T - 40$	ns
		$V_{\text{DD}} = 3.0 \text{ V}$			$1.5T - 60$	ns
Hold time from $\text{ASTB}\downarrow$ to $\overline{\text{WAIT}}$	$t_{\text{HSTWT}}$	$V_{\text{DD}} = 5.0 \text{ V}$	$(0.5 + n) T + 5$			ns
		$V_{\text{DD}} = 3.0 \text{ V}$	$(0.5 + n) T + 10$			ns
Delay time from $\text{ASTB}\downarrow$ to $\overline{\text{WAIT}}\uparrow$	$t_{\text{DSTWTH}}$	$V_{\text{DD}} = 5.0 \text{ V}$			$(1.5 + n) T - 40$	ns
		$V_{\text{DD}} = 3.0 \text{ V}$			$(1.5 + n) T - 60$	ns
Input time from $\overline{\text{RD}}\downarrow$ to $\overline{\text{WAIT}}\downarrow$	$t_{\text{DRWTL}}$	$V_{\text{DD}} = 5.0 \text{ V}$			$T - 40$	ns
		$V_{\text{DD}} = 3.0 \text{ V}$			$T - 60$	ns
Hold time from $\overline{\text{RD}}\downarrow$ to $\overline{\text{WAIT}}\downarrow$	$t_{\text{HRWT}}$	$V_{\text{DD}} = 5.0 \text{ V}$	$nT + 5$			ns
		$V_{\text{DD}} = 3.0 \text{ V}$	$nT + 10$			ns
Delay time from $\overline{\text{RD}}\downarrow$ to $\overline{\text{WAIT}}\uparrow$	$t_{\text{DRWTH}}$	$V_{\text{DD}} = 5.0 \text{ V}$			$(1 + n) T - 40$	ns
		$V_{\text{DD}} = 3.0 \text{ V}$			$(1 + n) T - 60$	ns
Input time from $\overline{\text{WAIT}}\uparrow$ to data	$t_{\text{DWTID}}$	$V_{\text{DD}} = 5.0 \text{ V}$			$0.5T - 5$	ns
		$V_{\text{DD}} = 3.0 \text{ V}$			$0.5T - 10$	ns
Delay time from $\overline{\text{WAIT}}\uparrow$ to $\overline{\text{RD}}\uparrow$	$t_{\text{DWTR}}$	$V_{\text{DD}} = 5.0 \text{ V}$	$0.5T$			ns
		$V_{\text{DD}} = 3.0 \text{ V}$	$0.5T$			ns
Delay time from $\overline{\text{WAIT}}\uparrow$ to $\overline{\text{WR}}\uparrow$	$t_{\text{DWTW}}$	$V_{\text{DD}} = 5.0 \text{ V}$	$0.5T$			ns
		$V_{\text{DD}} = 3.0 \text{ V}$	$0.5T$			ns
Input time from $\overline{\text{WR}}\downarrow$ to $\overline{\text{WAIT}}\downarrow$	$t_{\text{DWWTL}}$	$V_{\text{DD}} = 5.0 \text{ V}$			$T - 40$	ns
		$V_{\text{DD}} = 3.0 \text{ V}$			$T - 60$	ns
Hold time from $\overline{\text{WR}}\downarrow$ to $\overline{\text{WAIT}}$	$t_{\text{HWWT}}$	$V_{\text{DD}} = 5.0 \text{ V}$	$nT + 5$			ns
		$V_{\text{DD}} = 3.0 \text{ V}$	$nT + 10$			ns
Delay time from $\overline{\text{WR}}\downarrow$ to $\overline{\text{WAIT}}\uparrow$	$t_{\text{DWWTH}}$	$V_{\text{DD}} = 5.0 \text{ V}$			$(1 + n) T - 40$	ns
		$V_{\text{DD}} = 3.0 \text{ V}$			$(1 + n) T - 60$	ns

**Remark** T:  $t_{\text{CYK}} = 1/f_{\text{XX}}$  ( $f_{\text{XX}}$ : main system clock frequency)

a: 1 (during address wait), otherwise 0

n: Number of waits ( $n \geq 0$ )

Serial Operation ( $T_A = -40$  to  $+85^\circ\text{C}$ ,  $V_{DD} = AV_{DD} = 2.2$  to  $5.5$  V,  $V_{SS} = AV_{SS} = 0$  V)

(a) 3-wire serial I/O mode ( $\overline{\text{SCK}}$ : internal clock output)

Parameter	Symbol	Conditions	MIN.	TYP.	MAX.	Unit
$\overline{\text{SCK}}$ cycle time	$t_{\text{KCY1}}$	$2.7 \text{ V} \leq V_{DD} \leq 5.5 \text{ V}$	800			ns
			3,200			ns
$\overline{\text{SCK}}$ high-/low-level width	$t_{\text{KH1}}$	$2.7 \text{ V} \leq V_{DD} \leq 5.5 \text{ V}$	350			ns
	$t_{\text{KL1}}$		1,500			ns
SI setup time (to $\overline{\text{SCK}}\uparrow$ )	$t_{\text{SIK1}}$	$2.7 \text{ V} \leq V_{DD} \leq 5.5 \text{ V}$	10			ns
			30			ns
SI hold time (from $\overline{\text{SCK}}\uparrow$ )	$t_{\text{KSI1}}$		40			ns
SO output delay time (from $\overline{\text{SCK}}\downarrow$ )	$t_{\text{KSO1}}$				30	ns

(b) 3-wire serial I/O mode ( $\overline{\text{SCK}}$ : external clock input)

Parameter	Symbol	Conditions	MIN.	TYP.	MAX.	Unit
$\overline{\text{SCK}}$ cycle time	$t_{\text{KCY2}}$	$2.7 \text{ V} \leq V_{DD} \leq 5.5 \text{ V}$	800			ns
			3,200			ns
$\overline{\text{SCK}}$ high-/low-level width	$t_{\text{KH2}}$	$2.7 \text{ V} \leq V_{DD} \leq 5.5 \text{ V}$	400			ns
	$t_{\text{KL2}}$		1,600			ns
SI setup time (to $\overline{\text{SCK}}\uparrow$ )	$t_{\text{SIK2}}$	$2.7 \text{ V} \leq V_{DD} \leq 5.5 \text{ V}$	10			ns
			30			ns
SI hold time (from $\overline{\text{SCK}}\uparrow$ )	$t_{\text{KSI2}}$		40			ns
SO output delay time (from $\overline{\text{SCK}}\downarrow$ )	$t_{\text{KSO2}}$				30	ns

(c) UART mode

Parameter	Symbol	Conditions	MIN.	TYP.	MAX.	Unit
ASCK cycle time	$t_{\text{KCY3}}$	$4.5 \text{ V} \leq V_{DD} \leq 5.5 \text{ V}$	417			ns
		$2.7 \text{ V} \leq V_{DD} < 4.5 \text{ V}$	833			ns
			1,667			ns
ASCK high-/low-level width	$t_{\text{KH3}}$	$4.5 \text{ V} \leq V_{DD} \leq 5.5 \text{ V}$	208			ns
	$t_{\text{KL3}}$	$2.7 \text{ V} \leq V_{DD} < 4.5 \text{ V}$	416			ns
			833			ns

(d) I<sup>2</sup>C bus mode (μPD784218Y only)

Parameter		Symbol	Standard Mode		High-Speed Mode		Unit
			MIN.	MAX.	MIN.	MAX.	
SCL0 clock frequency		f <sub>CLK</sub>	0	100	0	400	kHz
Bus free time (between stop and start conditions)		t <sub>BUF</sub>	4.7	—	1.3	—	μs
Hold time <sup>Note 1</sup>		t <sub>HD : STA</sub>	4.0	—	0.6	—	μs
Low-level width of SCL0 clock		t <sub>LOW</sub>	4.7	—	1.3	—	μs
High-level width of SCL0 clock		t <sub>HIGH</sub>	4.0	—	0.6	—	μs
Setup time of start/restart conditions		t <sub>SU : STA</sub>	4.7	—	0.6	—	μs
Data hold time	When using CBUS-compatible master	t <sub>HD : DAT</sub>	5.0	—	—	—	μs
	When using I <sup>2</sup> C bus		0 <sup>Note 2</sup>	—	0 <sup>Note 2</sup>	0.9 <sup>Note 3</sup>	μs
Data setup time		t <sub>SU : DAT</sub>	250	—	100 <sup>Note 4</sup>	—	ns
Rise time of SDA0 and SCL0 signals		t <sub>r</sub>	—	1,000	20 + 0.1Cb <sup>Note 5</sup>	300	ns
Fall time of SDA0 and SCL0 signals		t <sub>f</sub>	—	300	20 + 0.1Cb <sup>Note 5</sup>	300	ns
Setup time of stop condition		t <sub>SU : STO</sub>	4.0	—	0.6	—	μs
Pulse width of spike restricted by input filter		t <sub>SF</sub>	—	—	0	50	ns
Load capacitance of each bus line		C <sub>b</sub>	—	400	—	400	pF

- Notes**
- For the start condition, the first clock pulse is generated after the hold time.
  - To fill the undefined area of the SCL0 falling edge, it is necessary for the device to provide an internal SDA0 signal (on V<sub>IHmin.</sub>) with at least 300 ns of hold time.
  - If the device does not extend the SCL0 signal low hold time (t<sub>LOW</sub>), only maximum data hold time t<sub>HD : DAT</sub> needs to be satisfied.
  - The high-speed mode I<sup>2</sup>C bus can be used in a standard mode I<sup>2</sup>C bus system. In this case, the conditions described below must be satisfied.
    - If the device does not extend the SCL0 signal low state hold time  
t<sub>SU : DAT</sub> ≥ 250 ns
    - If the device extends the SCL0 signal low state hold time  
Be sure to transmit the data bit to the SDA0 line before the SCL0 line is released  
(t<sub>Rmax.</sub> + t<sub>SU : DAT</sub> = 1,250 ns by standard mode I<sup>2</sup>C bus specification)
  - C<sub>b</sub>: total capacitance per one bus line (unit: pF)



**Other Operations (T<sub>A</sub> = -40 to +85°C, V<sub>DD</sub> = AV<sub>DD</sub> = 2.2 to 5.5 V, V<sub>SS</sub> = AV<sub>SS</sub> = 0 V)**

Parameter	Symbol	Conditions	MIN.	TYP.	MAX.	Unit
NMI high-/low-level width	t <sub>WNIL</sub>		10			μs
	t <sub>WNIH</sub>					
INTP input high-/low-level width	t <sub>WITL</sub>	INTP0 to INTP6	10			μs
	t <sub>WITL</sub>					
RESET high-/low-level width	t <sub>WRSL</sub>		10			μs
	t <sub>WRSH</sub>					

**Clock Output Operation (T<sub>A</sub> = -40 to +85°C, V<sub>DD</sub> = AV<sub>DD</sub> = 2.2 to 5.5 V, V<sub>SS</sub> = AV<sub>SS</sub> = 0 V)**

Parameter	Symbol	Conditions	MIN.	TYP.	MAX.	Unit
PCL cycle time	t <sub>CYCL</sub>	V <sub>DD</sub> = 4.5 to 5.5 V, nT	80		31,250	ns
PCL high-/low-level width	t <sub>CLL</sub>	V <sub>DD</sub> = 4.5 to 5.5 V, 0.5T - 10	30		15,615	ns
	t <sub>CLH</sub>					
PCL rise/fall time	t <sub>CLR</sub>	4.5 V ≤ V <sub>DD</sub> ≤ 5.5 V			5	ns
	t <sub>CLF</sub>	2.7 V ≤ V <sub>DD</sub> < 4.5 V			10	ns
		2.2 V ≤ V <sub>DD</sub> < 2.7 V			20	ns

**Remark** T: t<sub>CYK</sub> = 1/f<sub>XX</sub> (f<sub>XX</sub>: main system clock frequency)

n: Divided frequency ratio set by software in the CPU

- When using the main system clock: n = 1, 2, 4, 8, 16, 32, 64, 128
- When using the subsystem clock: n = 1

**A/D Converter Characteristics (T<sub>A</sub> = -40 to +85°C, V<sub>DD</sub> = AV<sub>DD</sub> = 2.2 to 5.5 V, V<sub>SS</sub> = AV<sub>SS</sub> = 0 V)**

Parameter	Symbol	Conditions	MIN.	TYP.	MAX.	Unit
Resolution			8	8	8	bit
Overall error <sup>Note</sup>		2.7 V ≤ AV <sub>REF0</sub> ≤ AV <sub>DD</sub>			±1.2	%
		2.2 V ≤ AV <sub>REF0</sub> < 2.7 V (only when AV <sub>REF0</sub> = AV <sub>DD</sub> )			±1.6	%
Conversion time	t <sub>CONV</sub>		14		144	μs
Sampling time	t <sub>SAMP</sub>		24/f <sub>XX</sub>			μs
Analog input voltage	V <sub>IAN</sub>		AV <sub>SS</sub>		AV <sub>REF0</sub>	V
Reference voltage	AV <sub>REF0</sub>		2.2		AV <sub>DD</sub>	V
Resistance between AV <sub>REF0</sub> and AV <sub>SS</sub>	R <sub>AVREF0</sub>			29.4		kΩ

**Note** Excludes quantization error (±1/2 LSB).

**Remark** f<sub>xx</sub>: Main system clock frequency

**D/A Converter Characteristics (T<sub>A</sub> = -40 to +85°C, V<sub>DD</sub> = AV<sub>DD</sub> = 2.2 to 5.5 V, V<sub>SS</sub> = AV<sub>SS</sub> = 0 V)**

Parameter	Symbol	Conditions	MIN.	TYP.	MAX.	Unit	
Resolution			8	8	8	bit	
Total error		R = 2 MΩ, 2.2 V < AV <sub>REF1</sub> ≤ 5.5 V			±1.2	%	
		R = 4 MΩ, 2.2 V < AV <sub>REF1</sub> ≤ 5.5 V			±0.8	%	
		R = 10 MΩ, 2.2 V < AV <sub>REF1</sub> ≤ 5.5 V			±0.6	%	
Settling time		Load conditions: C = 30 pF	4.5 V ≤ AV <sub>REF1</sub> ≤ 5.5 V			10	μs
			2.7 V ≤ AV <sub>REF1</sub> < 4.5 V			15	μs
			2.2 V ≤ AV <sub>REF1</sub> < 2.7 V			20	μs
★ Output resistance	R <sub>O</sub>	DACS0, 1 = 55 H		5.3		kΩ	
Reference voltage	AV <sub>REF1</sub>		2.2		V <sub>DD</sub>	V	
AV <sub>REF1</sub> current	AI <sub>REF1</sub>	For only 1 channel			2.5	mA	

**Data Retention Characteristics (T<sub>A</sub> = -40 to +85°C, V<sub>DD</sub> = AV<sub>DD</sub> = 2.2 to 5.5 V, V<sub>SS</sub> = AV<sub>SS</sub> = 0 V)**

Parameter	Symbol	Conditions	MIN.	TYP.	MAX.	Unit
Data retention voltage	V <sub>DDDR</sub>	STOP mode	2.2		5.5	V
Data retention current	I <sub>DDDR</sub>	V <sub>DDDR</sub> = +4.5 to 5.5 V		10	50	μA
		V <sub>DDDR</sub> = +2.5 V		2	10	μA
V <sub>DD</sub> rise time	t <sub>RVD</sub>		200			μs
V <sub>DD</sub> fall time	t <sub>FVD</sub>		200			μs
V <sub>DD</sub> hold time (from STOP mode setting)	t <sub>HVD</sub>		0			ms
STOP release signal input time	t <sub>DREL</sub>		0			ms
Oscillation stabilization wait time	t <sub>WAIT</sub>	Crystal resonator	30			ms
		Ceramic resonator	5			ms
Input voltage, low	V <sub>IL</sub>	RESET, P00/INTP0 to P06/INTP6	0		0.1V <sub>DDDR</sub>	V
Input voltage, high	V <sub>IH</sub>		0.9V <sub>DDDR</sub>		V <sub>DDDR</sub>	V

**AC Timing Measurement Points**

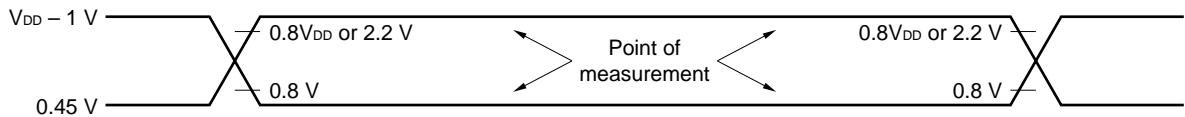





Serial Operation

(1) 3-wire serial I/O mode

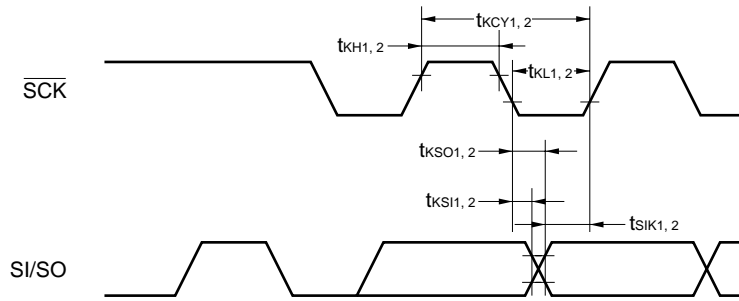

(2) UART mode

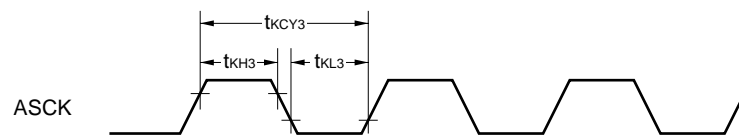

(3) I<sup>2</sup>C bus mode ( $\mu$ PD784218Y Subseries only)

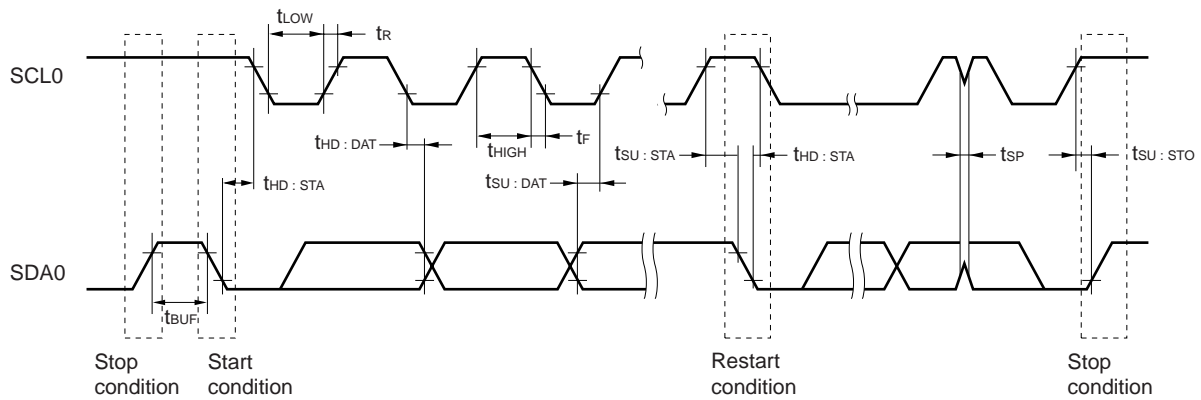

**Clock Output Timing**

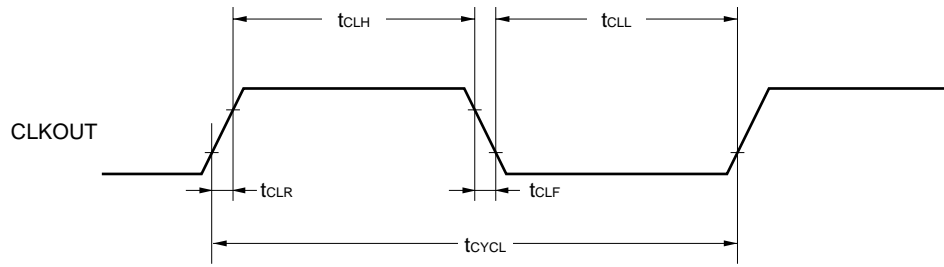

**Interrupt Input Timing**

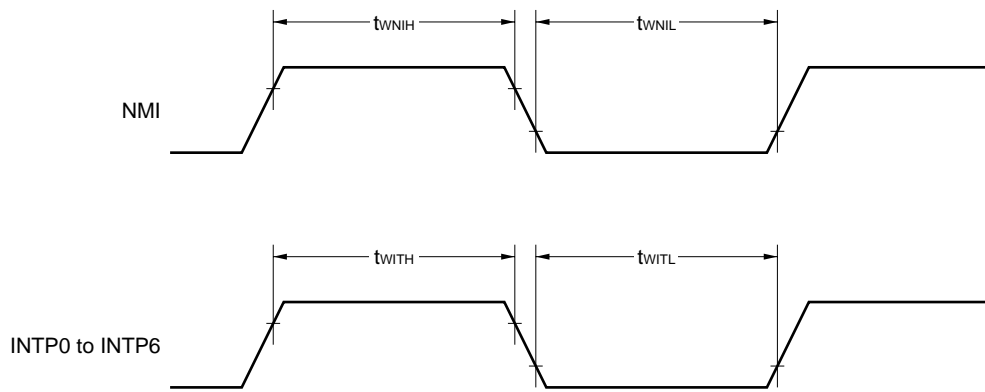

**Reset Input Timing**

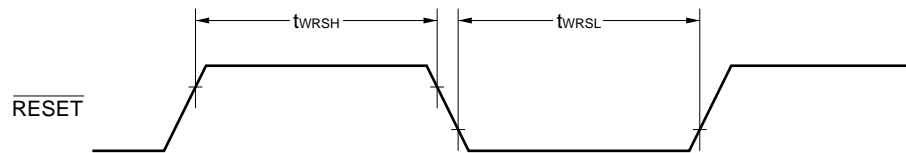

**Clock Timing**

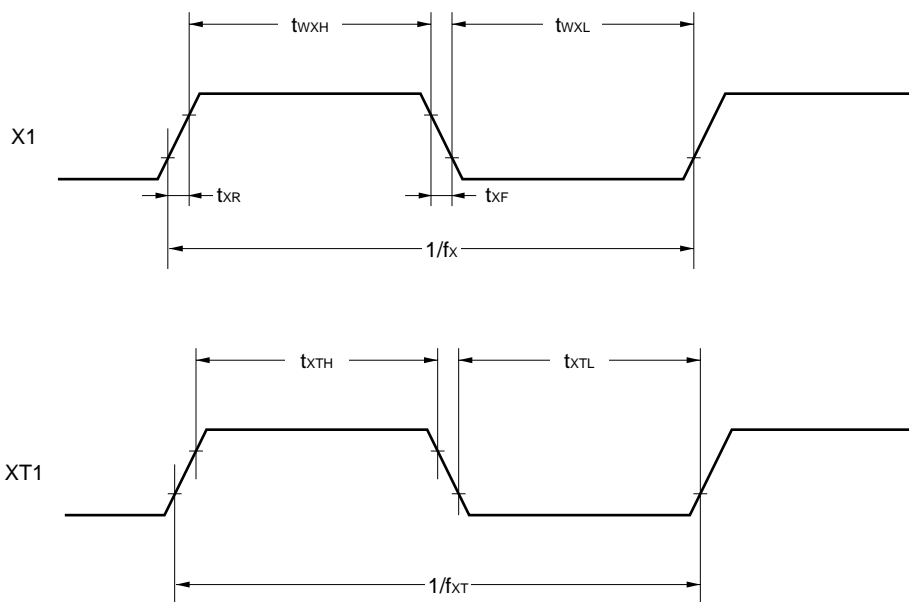

**Data Retention Characteristics**

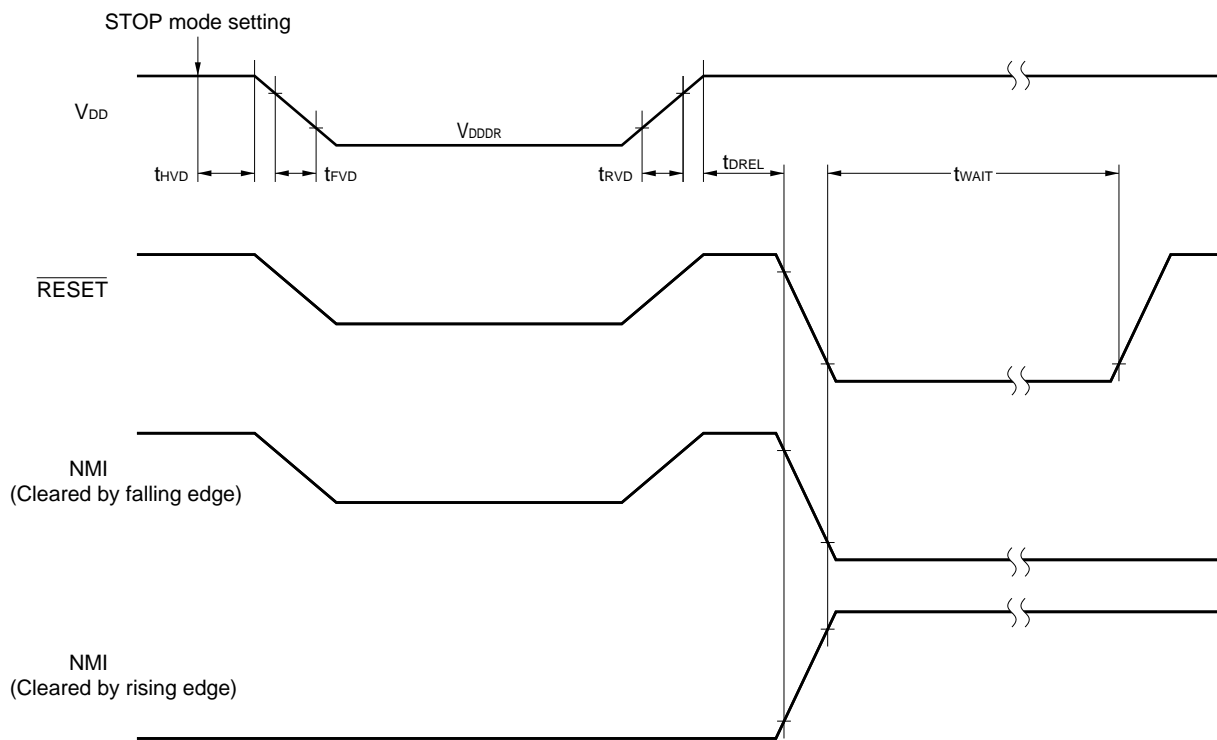



★ 16. PACKAGE DRAWINGS

100-PIN PLASTIC LQFP (FINE PITCH) (14x14)

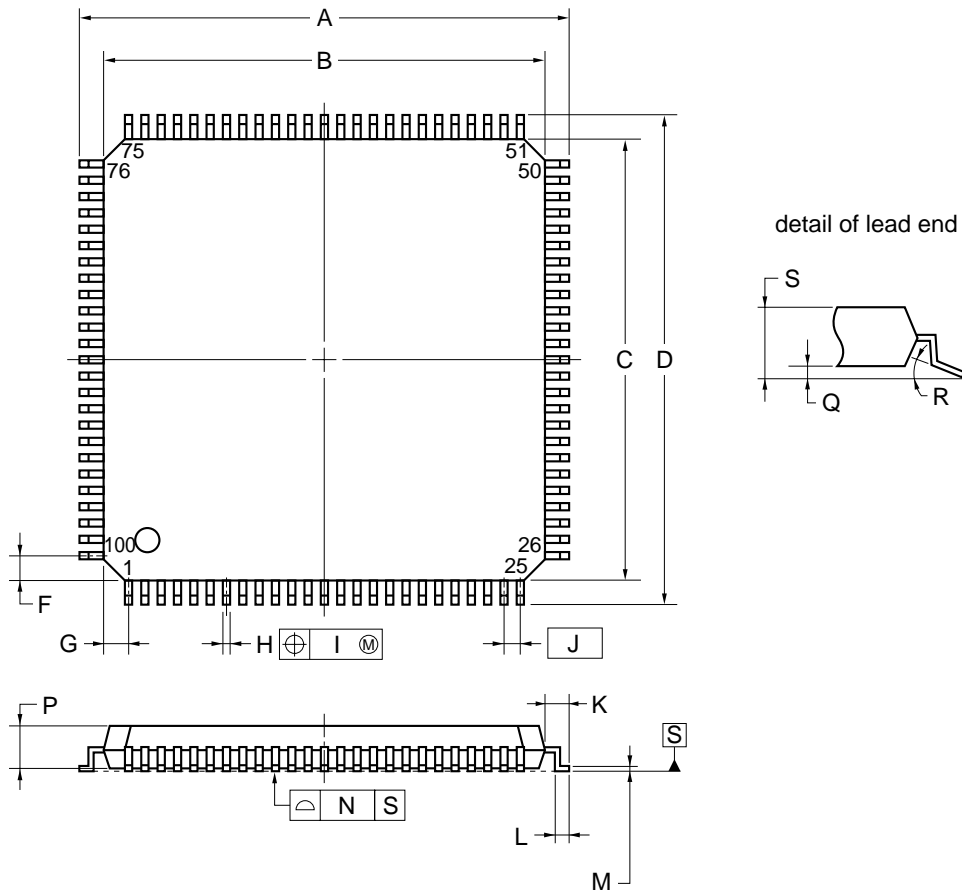

NOTE

Each lead centerline is located within 0.08 mm of its true position (T.P.) at maximum material condition.

ITEM	MILLIMETERS
A	16.00±0.20
B	14.00±0.20
C	14.00±0.20
D	16.00±0.20
F	1.00
G	1.00
H	0.22 <sup>+0.05</sup> <sub>-0.04</sub>
I	0.08
J	0.50 (T.P.)
K	1.00±0.20
L	0.50±0.20
M	0.17 <sup>+0.03</sup> <sub>-0.07</sub>
N	0.08
P	1.40±0.05
Q	0.10±0.05
R	3° <sup>+7°</sup> <sub>-3°</sub>
S	1.60 MAX.

S100GC-50-8EU-1

**Remark** The external dimensions and material of the ES version are the same as those of the mass-produced version.

100-PIN PLASTIC QFP (14x20)

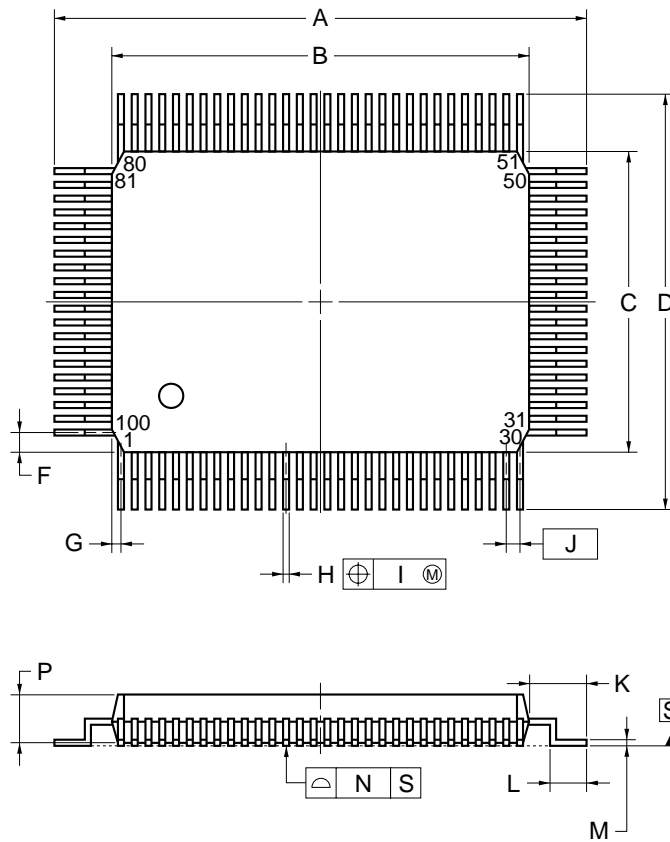

detail of lead end

NOTE

Each lead centerline is located within 0.15 mm of its true position (T.P.) at maximum material condition.

ITEM	MILLIMETERS
A	23.6±0.4
B	20.0±0.2
C	14.0±0.2
D	17.6±0.4
F	0.8
G	0.6
H	0.30±0.10
I	0.15
J	0.65 (T.P.)
K	1.8±0.2
L	0.8±0.2
M	0.15 <sup>+0.10</sup> <sub>-0.05</sub>
N	0.10
P	2.7±0.1
Q	0.1±0.1
R	5°±5°
S	3.0 MAX.

P100GF-65-3BA1-4

**Remark** The external dimensions and material of the ES version are the same as those of the mass-produced version.

★ 17. RECOMMENDED SOLDERING CONDITIONS

The μPD784218 should be soldered and mounted under the following recommended conditions. For the details of the recommended soldering conditions, refer to the document **Semiconductor Device Mounting Technology Manual (C10535E)**.

For soldering methods and conditions other than those recommended below, contact your NEC sales representative.

**Caution** Soldering conditions for the μPD784218YGC-xxx-8EU and μPD784218YGF-xxx-3BA are undetermined because these products are under development.

Table 17-1. Soldering Conditions for Surface Mount Type

(1) μPD784218GC-xxx-8EU: 100-pin plastic LQFP (Fine pitch) (14 × 14 mm)

Soldering Method	Soldering Conditions	Recommended Condition Symbol
Infrared reflow	Package peak temperature: 235°C, Time: 30 seconds max. (at 210°C or higher), Count: Two times or less, Exposure limit: 7 days <sup>Note</sup> (after that, prebake at 125°C for 10 hours)	IR35-107-2
VPS	Package peak temperature: 215°C, Time: 40 seconds max. (at 200°C or higher), Count: Two times or less, Exposure limit: 7 days <sup>Note</sup> (after that, prebake at 125°C for 10 hours)	VP-15-107-2
Partial heating	Pin temperature: 300°C max., Time: 3 seconds max. (per pin row)	—

**Note** After opening the dry pack, store it at 25°C or less and 65% RH or less for the allowable storage period.

**Caution** Do not use different soldering methods together (except for partial heating).

(2) μPD784218GF-xxx-3BA: 100-pin plastic QFP (14 × 20 mm)

Soldering Method	Soldering Conditions	Recommended Condition Symbol
Infrared reflow	Package peak temperature: 235°C, Time: 30 seconds max. (at 210°C or higher), Count: Two times or less	IR35-00-2
VPS	Package peak temperature: 215°C, Time: 40 seconds max. (at 200°C or higher), Count: Two times or less	VP15-00-2
Wave soldering	Solder bath temperature: 260°C max., Time: 10 seconds max., Count: Once, Preheating temperature: 120°C max. (package surface temperature)	WS60-00-1
Partial heating	Pin temperature: 300°C max., Time: 3 seconds max. (per pin row)	—

**Caution** Do not use different soldering methods together (except for partial heating).

## APPENDIX A DEVELOPMENT TOOLS

The following development tools are available for system development using the  $\mu$ PD784218. Also refer to (5) **Cautions on Using Development Tools.**

### (1) Language Processing Software

RA78K4	Assembler package common to 78K/IV Series
CC78K4	C compiler package common to 78K/IV Series
DF784218	Device file common to $\mu$ PD784218, 784218Y Subseries
CC78K4-L	C compiler library source file common to 78K/IV Series

### (2) Flash Memory Writing Tools

Flashpro II (Part No.: FL-PR2), Flashpro III (Part No.: FL-PR3, PG-FP3)	Dedicated flash programmer for microcontroller incorporating flash memory
FA-100GF	Adapter for writing 100-pin plastic QFP (GF-3BA type) flash memory.
FA-100GC	Adapter for writing 100-pin plastic LQFP (GC-8EU type) flash memory.

### (3) Debugging Tools

- **When IE-78K4-NS in-circuit emulator is used**

IE-78K4-NS	In-circuit emulator common to 78K/IV Series
IE-70000-MC-PS-B	Power supply unit for IE-78K4-NS
IE-70000-98-IF-C	Interface adapter used when PC-9800 series PC (except notebook type) is used as host machine (C bus supported)
IE-70000-CD-IF-A	PC card and cable when notebook PC is used as host machine (PCMCIA socket supported)
IE-70000-PC-IF-C	Interface adapter when using IBM PC/AT™ or compatible as host machine (ISA bus supported)
IE-70000-PCI-IF	Interface adapter when using PC that incorporates PCI bus as host machine
IE-784225-NS-EM1	Emulation board to emulate $\mu$ PD784218, 784218Y Subseries
NP-100GF	Emulation probe for 100-pin plastic QFP (GF-3BA type)
NP-100GC	Emulation probe for 100-pin plastic LQFP (GC-8EU type)
EV-9200GF-100	Socket to be mounted on a target system board made for 100-pin plastic QFP (GF-3BA type)
TGC-100SDW	Conversion adapter to connect the NP-100GC and a target system board on which a 100-pin plastic LQFP (GC-8EU type) can be mounted
ID78K4-NS	Integrated debugger for IE-78K4-NS
SM78K4	System simulator common to 78K/IV Series
DF784218	Device file common to $\mu$ PD784218, 784218Y Subseries

- **When IE-784000-R in-circuit emulator is used**

IE-784000-R	In-circuit emulator common to 78K/IV Series
IE-70000-98-IF-C	Interface adapter used when PC-9800 series PC (except notebook type) is used as host machine (C bus supported)
IE-70000-PC-IF-C	Interface adapter when using IBM PC/AT or compatible as host machine (ISA bus supported)
IE-70000-PCI-IF	Interface adapter when using PC that incorporates PCI bus as host machine
IE-78000-R-SV3	Interface adapter and cable used when EWS is used as host machine
IE-784225-NS-EM1 IE-784218-R-EM1	Emulation board to emulate μPD784218, 784218Y Subseries
IE-784000-R-EM	Emulation board common to 78K/IV Series
IE-78K4-R-EX3	Emulation probe conversion board necessary when using IE-784225-NS-EM1 on IE-784000-R. Not necessary when IE-784216-R-EM1 is used.
EP-78064GF-R	Emulation probe for 100-pin plastic QFP (GF-3BA type)
EP-78064GC-R	Emulation probe for 100-pin plastic LQFP (GC-8EU type)
EV-9200GF-100	Socket to be mounted on a target system board made for 100-pin plastic QFP (GF-3BA type)
TGC-100SDW	Conversion adapter to connect the NP-100GC and a target system board on which a 100-pin plastic LQFP (GC-8EU type) can be mounted
ID78K4	Integrated debugger for IE-784000-R
SM78K4	System simulator common to 78K/IV Series
DF784218	Device file common to μPD784218, 784218Y Subseries

**(4) Real-time OS**

RX78K/IV	Real-time OS for 78K/IV Series
MX78K4	OS for 78K/IV Series

**(5) Cautions on Using Development Tools**

- The ID78K4-NS, ID78K4, and SM78K4 are used in combination with the DF784218.
- The CC78K4 and RX78K/IV are used in combination with the RA78K4 and DF784218.
- The FL-PR2, FL-PR3, FA-100GF, FA-100GC, NP-100GF, and NP-100GC are products made by Naito Densei Machida Mfg. Co., Ltd. (TEL: +81-44-822-3813).
- The TGC-100SDW is a product made by TOKYO ELETECH CORPORATION.
- For further information, contact Daimaru Kogyo, Ltd.  
Tokyo Electronic Division (TEL: +81-3-3820-7112)  
Osaka Electronic Division (TEL: +81-6-6244-6672)
- For third-party development tools, see the **78K/IV Series Selection Guide (U13355E)**.
- The host machine and OS suitable for each software are as follows:

Host Machine [OS]  Software	PC	EWS
	PC-9800 series [Windows] IBM PC/AT and compatibles [Japanese/English Windows]	HP9000 series 700™ [HP-UX™] SPARCstation™ [SunOS™, Solaris™] NEWS™ (RISC) [NEWS-OS™]
RA78K4	√/Note	√
CC78K4	√/Note	√
ID78K4-NS	√	—
ID78K4	√	√
SM78K4	√	—
RX78K/IV	√/Note	√
MX78K4	√/Note	√

**Note** DOS-based software

**APPENDIX B RELATED DOCUMENTS**

**Documents Related to Devices**

Document Name	Document No.	
	Japanese	English
μPD784218, 784218Y Data Sheet	U12304J	This document
μPD78F4218, 78F4218Y Preliminary Product Information	U12440J	U12440E
μPD784218, 784218Y Subseries User's Manual Hardware	U12970J	U12970E
78K/IV Series User's Manual Instructions	U10905J	U10905E
78K/IV Series Instruction Table	U10594J	-
78K/IV Series Instruction Set	U10595J	-
78K/IV Series Application Note Software Fundamentals	U10095J	U10095E

**Documents Related to Development Tools (User's Manuals)**

Document Name		Document No.	
		Japanese	English
RA78K4 Assembler Package	Language	U11162J	U11162E
	Operation	U11334J	U11334E
RA78K Structured Assembler Preprocessor		U11743J	U11743E
CC78K4 C Compiler	Language	U11571J	U11571E
	Operation	U11572J	U11572E
IE-78K4-NS		U13356J	U13356E
IE-784000-R		U12903J	U12903E
IE-784218-R-EM1		U12155J	U12155E
IE-784225-NS-EM1		U13742J	U13742E
EP-78064		EEU-934	EEU-1469
SM78K4 System Simulator Windows Based	Reference	U10093J	U10093E
SM78K Series System Simulator	External Part User Open Interface Specifications	U10092J	U10092E
ID78K4-NS Integrated Debugger PC Based	Reference	U12796J	U12796E
ID78K4 Integrated Debugger Windows Based	Reference	U10440J	U10440E
ID78K4 Integrated Debugger HP-UX, SunOS, NEWS-OS Based	Reference	U11960J	U11960E

**Caution** The related documents listed above are subject to change without notice. Be sure to use the latest version of each document for designing.

**Documents Related to Embedded Software (User's Manuals)**

Document Name		Document No.	
		Japanese	English
78K/IV Series Real-Time OS	Fundamentals	U10603J	U10603E
	Installation	U10604J	U10604E
	Debugger	U10364J	-
78K/IV Series OS MK78K4	Fundamentals	U11779J	-

**Other Related Documents**

Document Name		Document No.	
		Japanese	English
SEMICONDUCTORS SELECTION GUIDE Products & Packages (CD-ROM)		X13769X	
Semiconductor Device Mounting Technology Manual		C10535J	C10535E
Quality Grades on NEC Semiconductor Devices		C11531J	C11531E
NEC Semiconductor Device Reliability/Quality Control System		C10983J	C10983E
Guide to Prevent Damage for Semiconductor Devices by Electrostatic Discharge (ESD)		C11892J	C11892E
Guide to Microcontroller-Related Products by Third Parties		U11416J	-

**Caution** The related documents listed above are subject to change without notice. Be sure to use the latest version of each document for designing.



[MEMO]

**NOTES FOR CMOS DEVICES****① PRECAUTION AGAINST ESD FOR SEMICONDUCTORS**

Note:

Strong electric field, when exposed to a MOS device, can cause destruction of the gate oxide and ultimately degrade the device operation. Steps must be taken to stop generation of static electricity as much as possible, and quickly dissipate it once, when it has occurred. Environmental control must be adequate. When it is dry, humidifier should be used. It is recommended to avoid using insulators that easily build static electricity. Semiconductor devices must be stored and transported in an anti-static container, static shielding bag or conductive material. All test and measurement tools including work bench and floor should be grounded. The operator should be grounded using wrist strap. Semiconductor devices must not be touched with bare hands. Similar precautions need to be taken for PW boards with semiconductor devices on it.

**② HANDLING OF UNUSED INPUT PINS FOR CMOS**

Note:

No connection for CMOS device inputs can be cause of malfunction. If no connection is provided to the input pins, it is possible that an internal input level may be generated due to noise, etc., hence causing malfunction. CMOS devices behave differently than Bipolar or NMOS devices. Input levels of CMOS devices must be fixed high or low by using a pull-up or pull-down circuitry. Each unused pin should be connected to  $V_{DD}$  or GND with a resistor, if it is considered to have a possibility of being an output pin. All handling related to the unused pins must be judged device by device and related specifications governing the devices.

**③ STATUS BEFORE INITIALIZATION OF MOS DEVICES**

Note:

Power-on does not necessarily define initial status of MOS device. Production process of MOS does not define the initial operation status of the device. Immediately after the power source is turned ON, the devices with reset function have not yet been initialized. Hence, power-on does not guarantee out-pin levels, I/O settings or contents of registers. Device is not initialized until the reset signal is received. Reset operation must be executed immediately after power-on for devices having reset function.

Purchase of NEC I<sup>2</sup>C components conveys a license under the Philips I<sup>2</sup>C Patent Rights to use these components in an I<sup>2</sup>C system, provided that the system conforms to the I<sup>2</sup>C Standard Specification as defined by Philips.

**IEBus is a trademark of NEC Corporation.**

**Windows is a registered trademark or a trademark of Microsoft Corporation in the United States and/or other countries.**

**PC/AT is a trademark of International Business Machines Corporation.**

**HP9000 series 700 and HP-UX are trademarks of Hewlett-Packard Company.**

**SPARCstation is a trademark of SPARC International, Inc.**

**Solaris and SunOS are trademarks of Sun Microsystems, Inc.**

**NEWS and NEWS-OS are trademarks of Sony Corporation.**

## Regional Information

Some information contained in this document may vary from country to country. Before using any NEC product in your application, please contact the NEC office in your country to obtain a list of authorized representatives and distributors. They will verify:

- Device availability
- Ordering information
- Product release schedule
- Availability of related technical literature
- Development environment specifications (for example, specifications for third-party tools and components, host computers, power plugs, AC supply voltages, and so forth)
- Network requirements

In addition, trademarks, registered trademarks, export restrictions, and other legal issues may also vary from country to country.

### NEC Electronics Inc. (U.S.)

Santa Clara, California  
Tel: 408-588-6000  
800-366-9782  
Fax: 408-588-6130  
800-729-9288

### NEC Electronics (Germany) GmbH

Duesseldorf, Germany  
Tel: 0211-65 03 02  
Fax: 0211-65 03 490

### NEC Electronics (UK) Ltd.

Milton Keynes, UK  
Tel: 01908-691-133  
Fax: 01908-670-290

### NEC Electronics Italiana s.r.l.

Milano, Italy  
Tel: 02-66 75 41  
Fax: 02-66 75 42 99

### NEC Electronics (Germany) GmbH

Benelux Office  
Eindhoven, The Netherlands  
Tel: 040-2445845  
Fax: 040-2444580

### NEC Electronics (France) S.A.

Velizy-Villacoublay, France  
Tel: 01-30-67 58 00  
Fax: 01-30-67 58 99

### NEC Electronics (France) S.A.

Spain Office  
Madrid, Spain  
Tel: 91-504-2787  
Fax: 91-504-2860

### NEC Electronics (Germany) GmbH

Scandinavia Office  
Taeby, Sweden  
Tel: 08-63 80 820  
Fax: 08-63 80 388

### NEC Electronics Hong Kong Ltd.

Hong Kong  
Tel: 2886-9318  
Fax: 2886-9022/9044

### NEC Electronics Hong Kong Ltd.

Seoul Branch  
Seoul, Korea  
Tel: 02-528-0303  
Fax: 02-528-4411

### NEC Electronics Singapore Pte. Ltd.

United Square, Singapore 1130  
Tel: 65-253-8311  
Fax: 65-250-3583

### NEC Electronics Taiwan Ltd.

Taipei, Taiwan  
Tel: 02-2719-2377  
Fax: 02-2719-5951

### NEC do Brasil S.A.

Electron Devices Division  
Rodovia Presidente Dutra, Km 214  
07210-902-Guarulhos-SP Brasil  
Tel: 55-11-6465-6810  
Fax: 55-11-6465-6829

J99.1

The related documents indicated in this publication may include preliminary versions. However, preliminary versions are not marked as such.

The export of this product from Japan is regulated by the Japanese government. To export this product may be prohibited without governmental license, the need for which must be judged by the customer. The export or re-export of this product from a country other than Japan may also be prohibited without a license from that country. Please call an NEC sales representative.

- **The information in this document is subject to change without notice. Before using this document, please confirm that this is the latest version.**
  - No part of this document may be copied or reproduced in any form or by any means without the prior written consent of NEC Corporation. NEC Corporation assumes no responsibility for any errors which may appear in this document.
  - NEC Corporation does not assume any liability for infringement of patents, copyrights or other intellectual property rights of third parties by or arising from use of a device described herein or any other liability arising from use of such device. No license, either express, implied or otherwise, is granted under any patents, copyrights or other intellectual property rights of NEC Corporation or others.
  - Descriptions of circuits, software, and other related information in this document are provided for illustrative purposes in semiconductor product operation and application examples. The incorporation of these circuits, software, and information in the design of the customer's equipment shall be done under the full responsibility of the customer. NEC Corporation assumes no responsibility for any losses incurred by the customer or third parties arising from the use of these circuits, software, and information.
  - While NEC Corporation has been making continuous effort to enhance the reliability of its semiconductor devices, the possibility of defects cannot be eliminated entirely. To minimize risks of damage or injury to persons or property arising from a defect in an NEC semiconductor device, customers must incorporate sufficient safety measures in its design, such as redundancy, fire-containment, and anti-failure features.
  - NEC devices are classified into the following three quality grades:  
"Standard", "Special", and "Specific". The Specific quality grade applies only to devices developed based on a customer designated "quality assurance program" for a specific application. The recommended applications of a device depend on its quality grade, as indicated below. Customers must check the quality grade of each device before using it in a particular application.
    - Standard: Computers, office equipment, communications equipment, test and measurement equipment, audio and visual equipment, home electronic appliances, machine tools, personal electronic equipment and industrial robots
    - Special: Transportation equipment (automobiles, trains, ships, etc.), traffic control systems, anti-disaster systems, anti-crime systems, safety equipment and medical equipment (not specifically designed for life support)
    - Specific: Aircraft, aerospace equipment, submersible repeaters, nuclear reactor control systems, life support systems or medical equipment for life support, etc.
- The quality grade of NEC devices is "Standard" unless otherwise specified in NEC's Data Sheets or Data Books. If customers intend to use NEC devices for applications other than those specified for Standard quality grade, they should contact an NEC sales representative in advance.