

SGM3005

Ultra Low ON-Resistance, Low Voltage, Dual, SPDT Analog Switch

GENERAL DESCRIPTION

The SGM3005 is a dual, low ON-resistance, low voltage, bidirectional, single-pole/double-throw (SPDT) CMOS analog switches designed to operate from a single +1.8V to +5.5V supply. Targeted applications include battery powered equipment that benefit from low R_{ON} (0.5Ω) and fast switching speeds ($t_{ON} = 16\text{ ns}$, $t_{OFF} = 15\text{ ns}$).

The on resistance profile is very flat over the full analog signal range. This ensures excellent linearity and low distortion when switching audio signals.

The SGM3005 is a committed dual single-pole/double-throw (SPDT) that consist of two normally open (NO) and two normally close (NC) switches. This configuration can be used as a dual 2-to-1 multiplexer.

SGM3005 is available in a MSOP-10 and DFN-10 packages.

APPLICATIONS

Battery powered, Handheld, and Portable Equipments
Cellular/mobile Phones
Laptops, Notebooks, Palmtops
Communication Systems
Sample-and-Hold Circuits
Audio Signal Routing
Audio and Video Switching
Portable Test and Measurement
Medical Equipment

FEATURES

- Low Voltage Operation : 1.8 V to 5.5 V
- Low On-Resistance: 0.5Ω (TYP)
- Low On-Resistance Flatness
- -3 dB Bandwidth: 30 MHz
- Fast Switching Time
 - t_{ON} 16 ns
 - t_{OFF} 15 ns
- Rail-to-Rail Operation
- Typical Power Consumption ($<0.01\ \mu\text{W}$)
- TTL/CMOS Compatible
- Microsize Package

PIN CONFIGURATIONS (TOP VIEW)

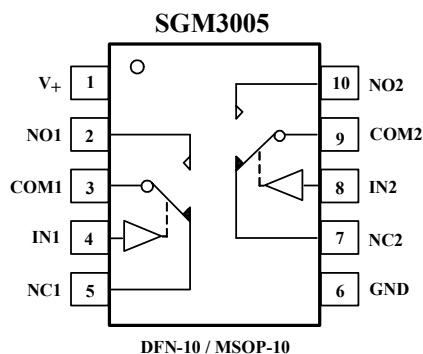

FUNCTION TABLE

LOGIC	NC1, NC2	NO1, NO2
0	ON	OFF
1	OFF	ON



ORDERING INFORMATION

MODEL	PIN-PACKAGE	SPECIFIED TEMPERATURE RANGE	ORDERING NUMBER	PACKAGE MARKING	PACKAGE OPTION
SGM3005	MSOP-10	- 40°C to +125°C	SGM3005XMS/TR	SGM3005XMS	Tape and Reel, 3000
	DFN-10	- 40°C to +125°C	SGM3005XD	3005D	Tape and Reel, 3000

ABSOLUTE MAXIMUM RATINGS

V₊ to GND.....- 0.3V to +6V
 Analog, Digital voltage range(1)..... - 0.3V to V₊ + 0.3V
 Continuous Current NO, NC, or COM..... ± 300mA
 Peak Current NO, NC, or COM..... ± 500mA
 Operating Temperature Range.....- 40°C to +125°C

Junction Temperature.....+150°C
 Storage Temperature.....- 65°C to +150°C
 Lead Temperature (soldering, 10s).....+300°C
 ESD.....2000V

Stresses beyond those listed under “Absolute Maximum Ratings” may cause permanent damage to the device. These are stress ratings only, and functional operation of the device at these or any other conditions beyond those indicated in the operational sections of the specifications is not implied. Exposure to absolute maximum rating conditions for extended periods may affect device reliability.

(1) Signals on NC, NO, or COM or IN exceeding V₊ will be clamped by internal diodes. Limit forward diode current to maximum current ratings.

PIN DESCRIPTION

NAME	PIN	FUNCTION
V ₊	1	Power supply
GND	6	ground
IN1, IN2	4,8	Digital control pin to connect the COM terminal to the NO or NC terminals
COM1, COM2	3,9	Common terminal
NO1, NO2	2,10	Normally-open terminal
NC1, NC2	5,7	Normally-closed terminal

Note: NO, NC and COM terminal may be an input or output.

ELECTRICAL CHARACTERISTICS

(V₊ = +5 V ± 10%, GND = 0 V, T_A = - 40°C to +125°C, unless otherwise noted. Typical values are at T_A = + 25°C.)

PARAMETER	SYMBOL	CONDITIONS	SGM3005			
			+25°C	- 40°C to +125°C	UNITS	MIN/MAX
ANALOG SWITCH						
Analog Signal Range	V _{NO} , V _{NC} , V _{COM}			0	V	MIN
				V ₊	V	MAX
On-Resistance	R _{ON}	0 ≤ V _{NO} or V _{NC} ≤ V ₊ , I _{COM} = -10 mA, Test Circuit 1	0.5		Ω	TYP
			0.9	1.1	Ω	MAX
On-Resistance Match Between Channels	ΔR _{ON}	0 ≤ V _{NO} or V _{NC} ≤ V ₊ , I _{COM} = -10 mA, Test Circuit 1	0.05		Ω	TYP
			0.09	0.12	Ω	MAX
On-Resistance Flatness	R _{FLAT(ON)}	0 ≤ V _{NO} or V _{NC} ≤ V ₊ , I _{COM} = -10 mA, Test Circuit 1	0.25		Ω	TYP
			0.3	0.4	Ω	MAX
LEAKAGE CURRENTS						
Source OFF Leakage current	I _{NC(OFF)} , I _{NO(OFF)}	V _{NO} or V _{NC} = 4.5V/1V, V _{COM} = 1V/4.5V, V ₊ = +5.5V, Test Circuit 2	±4		nA	TYP
			±10	±1000	nA	MAX
Channel ON Leakage current	I _{NC(ON)} , I _{NO(ON)} , I _{COM(ON)}	V _{NO} or V _{NC} = V _{COM} = 1V or 4.5V, V ₊ = +5.5V, Test Circuit 3	±4		nA	TYP
			±10	±1000	nA	MAX
DIGITAL INPUTS						
Input High Voltage	V _{INH}			2.4	V	MIN
Input Low Voltage	V _{INL}			0.8	V	MAX
Input Current	I _{INL} or I _{INH}	V _{IN} = V _{INH} or V _{INL}	±0.01		μA	TYP
			±0.1	±1	μA	MAX
DYNAMIC CHARACTERISTICS						
Turn-On Time	t _{ON}	V _{NO} or V _{NC} = 3V, R _L = 300Ω, C _L = 35pF, Test Circuit 4	16		ns	TYP
Turn-Off Time	t _{OFF}	V _{NO} or V _{NC} = 3V, R _L = 300Ω, C _L = 35pF, Test Circuit 4	15		ns	TYP
Charge Injection,	Q	C _L = 1.0nF, V _G = 0V, R _G = 0, Test Circuit 5	1		pC	TYP
Break-Before-Make Time Delay	t _D	V _{NO1} or V _{NC1} = V _{NO2} or V _{NC2} = 3V, R _L = 300Ω, C _L = 35pF, Test Circuit 6	10		ns	TYP
Off Isolation	O _{ISO}	R _L = 50Ω, C _L = 5pF, Test Circuit 7	f = 100KHz	-75	dB	TYP
			f = 10KHz	-85	dB	TYP
Channel-to-Channel Crosstalk	X _{TALK}	R _L = 50Ω, C _L = 5pF, Test Circuit 8	f = 100KHz	-90	dB	TYP
			f = 10KHz	-105	dB	TYP
Total Harmonic Distortion	THD	f = 20Hz to 20KHz, V _{COM} = 3.5V _{P-P} , R _L = 600Ω, C _L = 50pF	0.065		%	TYP
Bandwidth -3 dB	BW	R _L = 50Ω, C _L = 5pF, Test Circuit 9	30		MHz	TYP
Source OFF Capacitance	C _{NC(OFF)} , C _{NO(OFF)}		82		pF	TYP
Channel ON Capacitance	C _{NC(ON)} , C _{NO(ON)} , C _{COM(ON)}		380		pF	TYP
POWER REQUIREMENTS						
Power Supply Current	I ₊	V ₊ = +5.5V, V _{IN} = 0V or 5V	0.001		μA	TYP
				1	μA	MAX

Specifications subject to change without notice.

ELECTRICAL CHARACTERISTICS

(V₊ = +3 V ± 10%, GND = 0 V, T_A = - 40°C to +125°C, unless otherwise noted. Typical values are at T_A = + 25°C.)

PARAMETER	SYMBOL	CONDITIONS	SGM3005			
			+25°C	- 40°C to +125°C	UNITS	MIN/MAX
ANALOG SWITCH						
Analog Signal Range	V _{NO} , V _{NC} , V _{COM}			0 V ₊	V V	MIN MAX
On-Resistance	R _{ON}	0 ≤ V _{NO} or V _{NC} ≤ V ₊ , I _{COM} = -10 mA, Test Circuit 1	0.6		Ω	TYP
			1.0	1.3	Ω	MAX
On-Resistance Match Between Channels	ΔR _{ON}	0 ≤ V _{NO} or V _{NC} ≤ V ₊ , I _{COM} = -10 mA, Test Circuit 1	0.05		Ω	TYP
			0.1	0.13	Ω	MAX
On-Resistance Flatness	R _{FLAT(ON)}	0 ≤ V _{NO} or V _{NC} ≤ V ₊ , I _{COM} = -10 mA, Test Circuit 1	0.25		Ω	TYP
			0.3	0.4	Ω	MAX
LEAKAGE CURRENTS						
Source OFF Leakage current	I _{NC(OFF)} , I _{NO(OFF)}	V _{NO} or V _{NC} = 3V/1V, V _{COM} = 1V/3V, V ₊ = +3.3V, Test Circuit 2	±5		nA	TYP
			±11	±1000	nA	MAX
Channel ON Leakage current	I _{NC(ON)} , I _{NO(ON)} , I _{COM(ON)}	V _{NO} or V _{NC} = V _{COM} = 1V or 3V, V ₊ = +3.3V, Test Circuit 3	±5		nA	TYP
			±11	±1000	nA	MAX
DIGITAL INPUTS						
Input High Voltage	V _{INH}			2.0	V	MIN
Input Low Voltage	V _{INL}			0.4	V	MAX
Input Current	I _{INL} or I _{INH}	V _{IN} = V _{INH} or V _{INL}	±0.01		μA	TYP
			±0.1	±1	μA	MAX
DYNAMIC CHARACTERISTICS						
Turn-On Time	t _{ON}	V _{NO} or V _{NC} = 2V, R _L = 300Ω, C _L = 35pF, Test Circuit 4	17		ns	TYP
Turn-Off Time	t _{OFF}	V _{NO} or V _{NC} = 2V, R _L = 300Ω, C _L = 35pF, Test Circuit 4	16		ns	TYP
Charge Injection,	Q	C _L = 1.0nF, V _G = 0V, R _G = 0, Test Circuit 5	3		pC	TYP
Break-Before-Make Time Delay	t _d	V _{NO1} or V _{NC1} = V _{NO2} or V _{NC2} = 2V, R _L = 300Ω, C _L = 35pF, Test Circuit 6	11		ns	TYP
Off Isolation	O _{ISO}	R _L = 50Ω, C _L = 5pF, Test Circuit 7	f = 100KHz	-75	dB	TYP
			f = 10KHz	-85	dB	TYP
Channel-to-Channel Crosstalk	X _{TALK}	R _L = 50Ω, C _L = 5pF, Test Circuit 8	f = 100KHz	-90	dB	TYP
			f = 10KHz	-105	dB	TYP
Total Harmonic Distortion	THD	f = 20Hz to 20KHz, V _{COM} = 2V _{P-P} , R _L = 600Ω, C _L = 50pF	0.06		%	TYP
Bandwidth -3 dB	BW	R _L = 50Ω, C _L = 5pF, Test Circuit 9	30		MHz	TYP
Source OFF Capacitance	C _{NC(OFF)} , C _{NO(OFF)}		82		pF	TYP
Channel ON Capacitance	C _{NC(ON)} , C _{NO(ON)} , C _{COM(ON)}		380		pF	TYP
POWER REQUIREMENTS						
Power Supply Current	I ₊	V ₊ = +3.3V, V _{IN} = 0V or 3V	0.001		μA	TYP
				1	μA	MAX

Specifications subject to change without notice.

TYPICAL PERFORMANCE CHARACTERISTICS

On Resistance vs. Supply Voltage vs. Switch Voltage

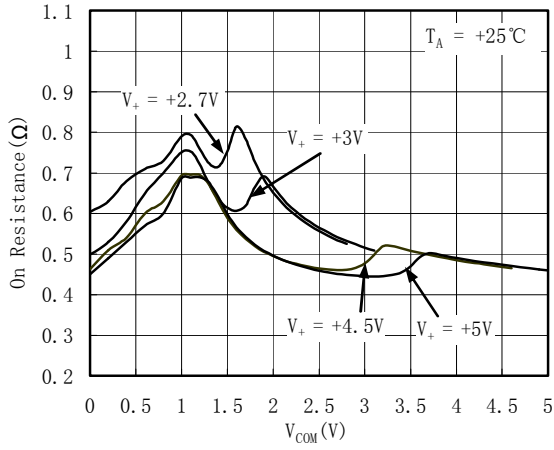

On Response vs. Frequency

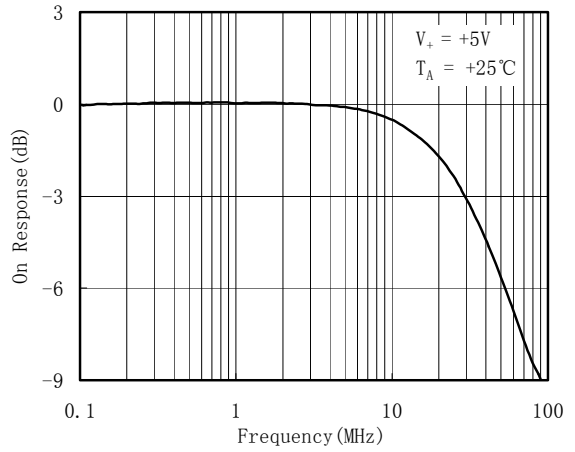

On Resistance vs. Switch Voltage

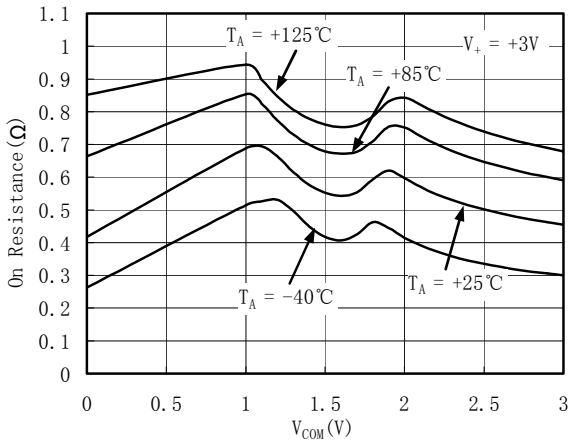

On Resistance vs. Switch Voltage

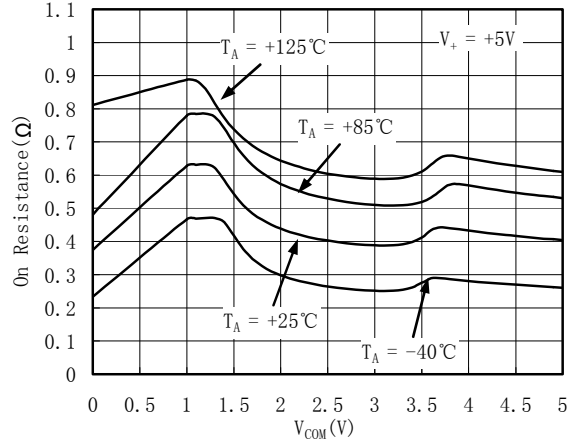

Crosstalk vs. Frequency

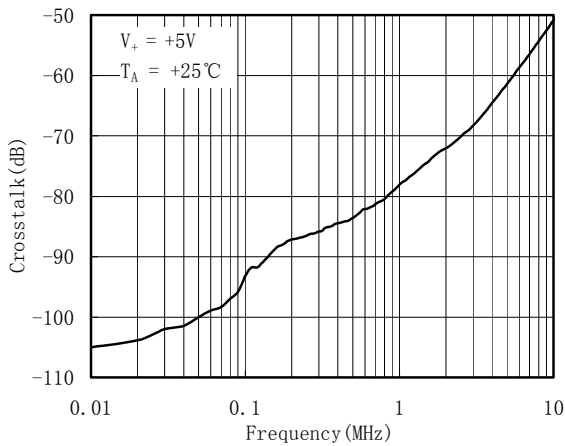

Off Isolation vs. Frequency

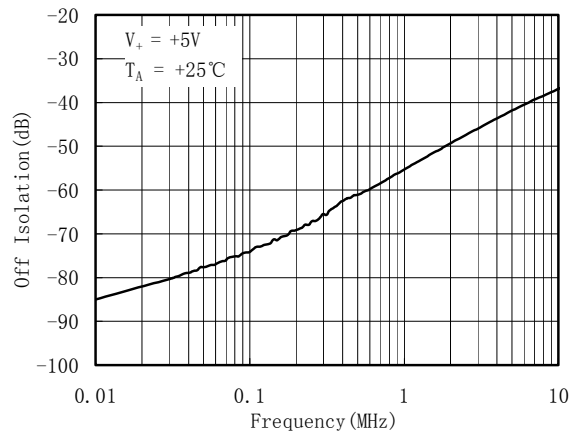

TEST CIRCUITS

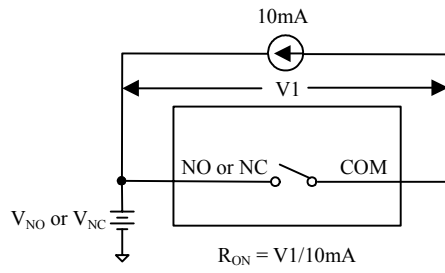

Test Circuit 1. On Resistance

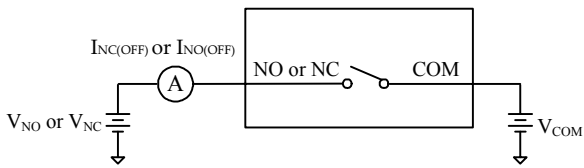

Test Circuit 2: Off Leakage

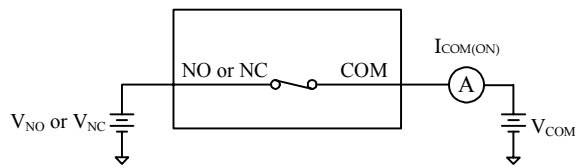

Test Circuit 3: On Leakage

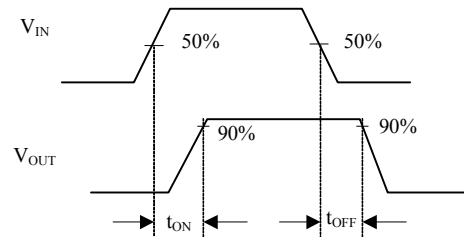
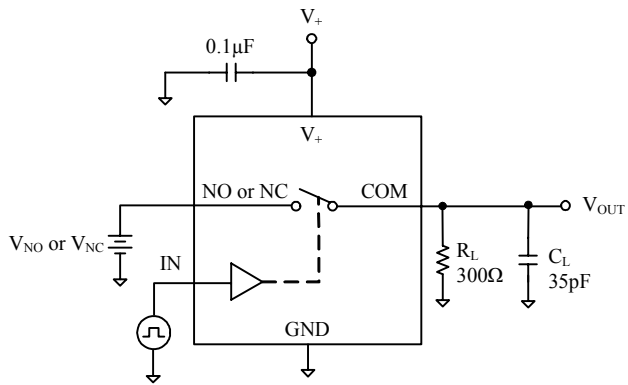

Test Circuit 4: Switching Times

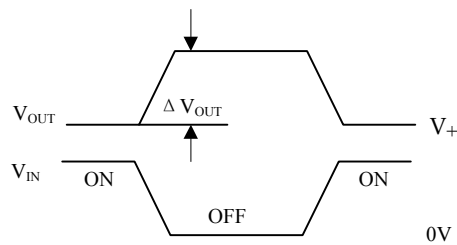
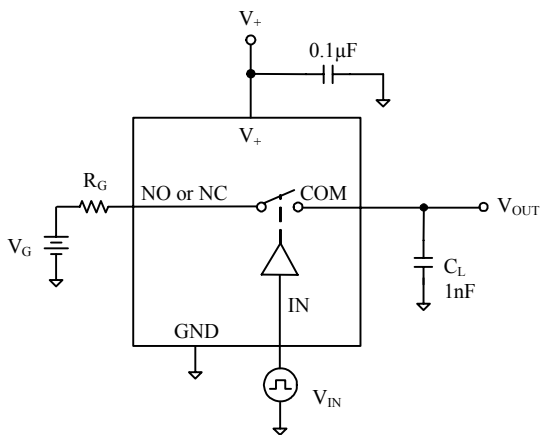

Test Circuit 5: Charge Injection

TEST CIRCUITS(Cont.)

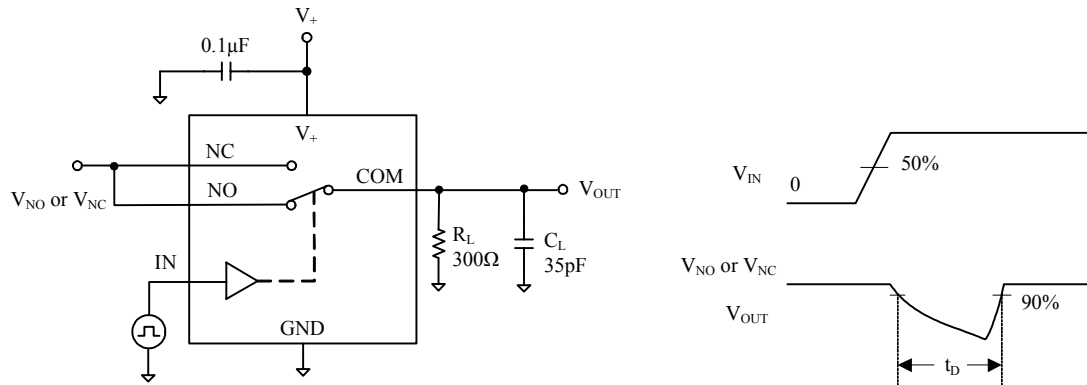

Test Circuit 6. Break-Before-Make Time Delay, t_d

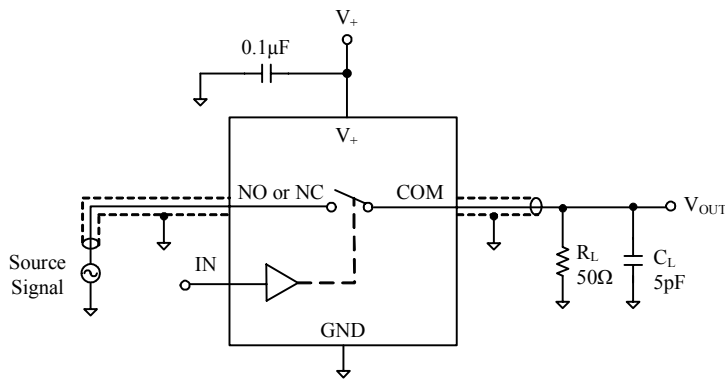

Test Circuit 7. Off Isolation

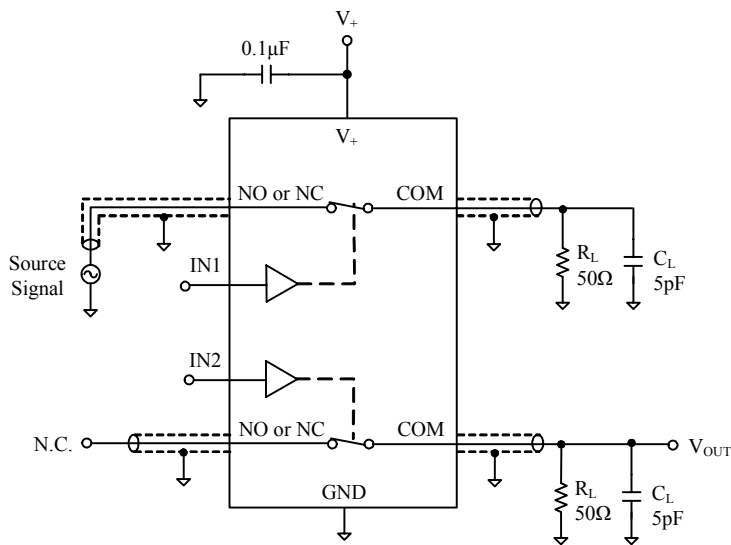

$$\text{Channel To Channel Crosstalk} = -20 \times \log \frac{V_{NO \text{ or } V_{NC}}}{V_{OUT}}$$

Test Circuit 8. Channel-to-Channel Crosstalk

TEST CIRCUITS(Cont.)

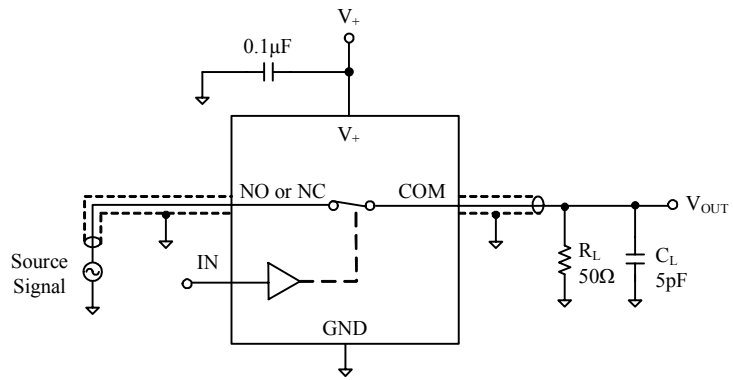

Test Circuit 9. Bandwidth

PACKAGE OUTLINE DIMENSIONS

MSOP-10

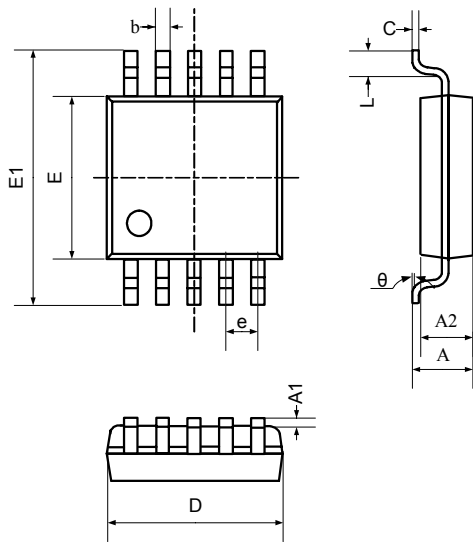

Symbol	Dimensions In Millimeters		Dimensions In Inches	
	Min	Max	Min	Max
A	0.800	1.200	0.031	0.047
A1	0.000	0.200	0.000	0.008
A2	0.760	0.970	0.030	0.038
b	0.30 TYP		0.012 TYP	
c	0.152 TYP		0.006 TYP	
D	2.900	3.100	0.114	0.122
e	0.50 TYP		0.020 TYP	
E	2.900	3.100	0.114	0.122
E1	4.700	5.100	0.185	0.201
L	0.410	0.650	0.016	0.026
theta	0°	6°	0°	6°

PACKAGE OUTLINE DIMENSIONS

DFN-10

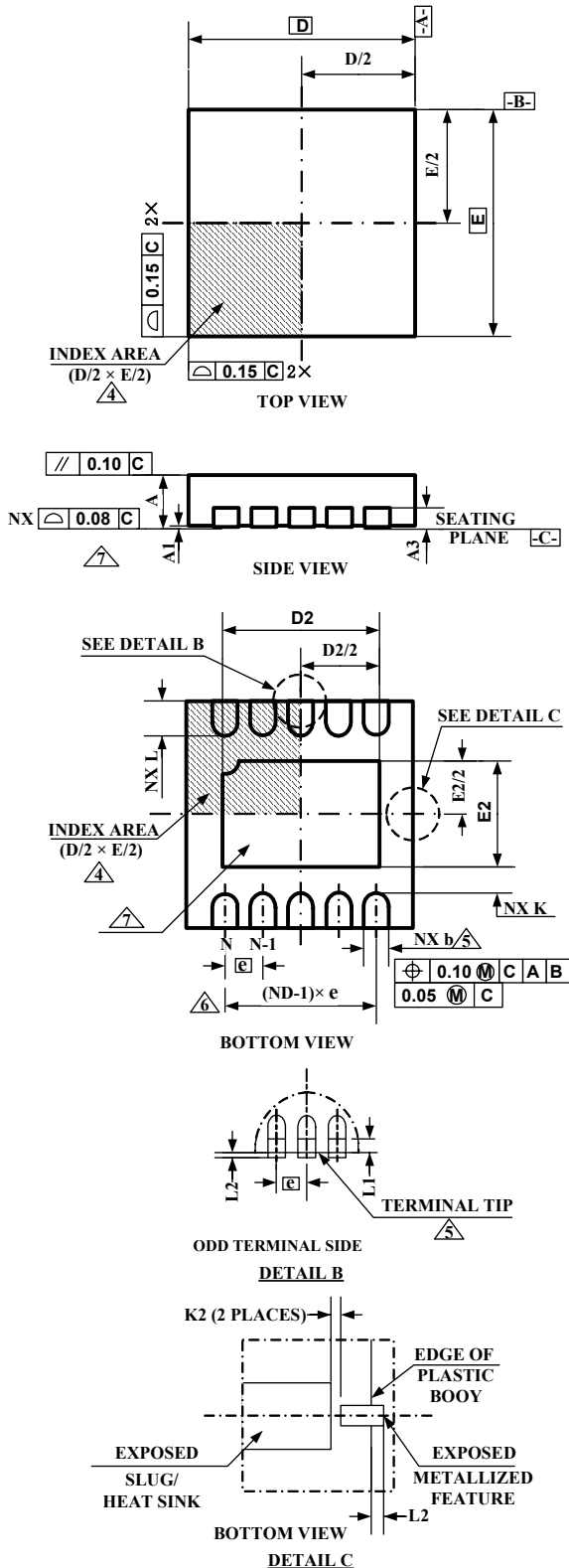

Symbol	Dimensions In Millimeters		
	Min	NOM	Max
A	0.70	0.75	0.80
A1	0.00	0.02	0.05
A3	0.20 REF		
b	0.18	0.25	0.30
D	3.00 BSC		
D2	2.23	2.38	2.48
E	3.00 BSC		
E2	1.49	1.64	1.74
e	0.50 BSC		
K	0.20		
K2	0.17		
L	0.30	0.40	0.50
L1			0.15
L2			0.13
N	10		
ND	5		

NOTES:

1. Dimensioning and tolerancing conform to ASME Y14.5M-1994.
2. All dimensions are in millimeters, angle is in degrees ($^{\circ}$).
3. N is the total number of terminals.
4. The terminal #1 identifier and terminal numbering convention shall conform to JESD 95-1 SPP-012. Details of terminal #1 identifier are optional, but must be located within the zone indicated. The terminal #1 identifier may be either a mold, embedded metal or mark feature.
5. Dimension b applies to metallized terminal and is measured between 0.15MM and 0.30MM from terminal tip.
6. ND refers to the maximum number of terminals on D side.
7. Unilateral coplanarity zone applies to the exposed heat sink slug as well as the terminals.