

FEATURES

- **High Current Transfer Ratios**
 - at 5 mA: 50–600%
 - at 1 mA: 60% typical (>13)
- **Low CTR Degradation**
- **Good CTR Linearity Depending on Forward Current**
- **Isolation Test Voltage, 5300 VACRMS**
- **High Collector-Emitter Voltage, VCEO=70 V**
- **Low Saturation Voltage**
- **Fast Switching Times**
- **Field-Effect Stable by TRIOS (TRansparent IO n Shield)**
- **Temperature Stable**
- **Low Coupling Capacitance**
- **End-Stackable, .100"(2.54 mm) Spacing**
- **High Common-Mode Interference Immunity (Unconnected Base)**
- **Underwriters Lab File #52744**
- **VDE 0884 Available with Option 1**
- **SMD Option – See SFH6106/16/56 Data Sheet**

DESCRIPTION

The SFH615AA/AGB/AGR features a high current transfer ratio, low coupling capacitance and high isolation voltage. These couplers have a GaAs infrared emitting diode emitter, which is optically coupled to a silicon planar phototransistor detector, and is incorporated in a plastic DIP-4 package.

The coupling devices are designed for signal transmission between two electrically separated circuits.

The couplers are end-stackable with 2.54 mm spacing.

Creepage and clearance distances of >8 mm are achieved with option 6. This version complies with IEC 950 (DIN VDE 0805) for reinforced insulation up to an operation voltage of 400 V_{RMS} or DC.

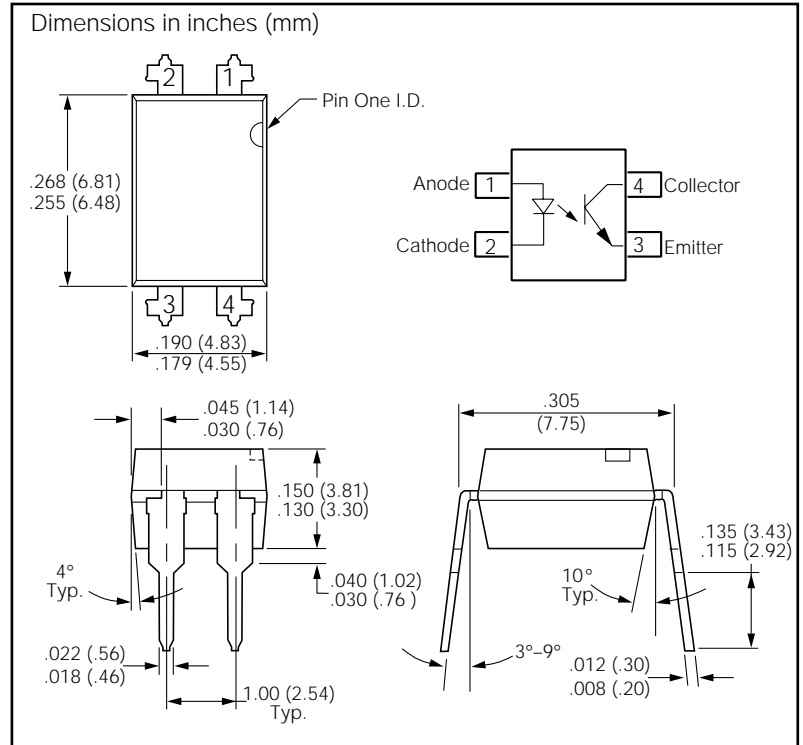

Maximum Ratings

Emitter

Reverse Voltage	6 V
DC Forward Current	60 mA
Surge Forward Current ($t_p \leq 10 \mu s$)	2.5 A
Total Power Dissipation	100 mW

Detector

Collector-Emitter Voltage	70 V
Emitter-Collector Voltage	7 V
Collector Current	50 mA
Collector Current ($t_p \leq 1 ms$)	100 mA
Total Power Dissipation	150 mW

Package

Isolation Test Voltage between Emitter and Detector, refer to Climate DIN 40046, part 2, Nov. 74	5300 VAC _{RMS}
Creepage	≥7 mm
Clearance	≥7 mm
Insulation Thickness between Emitter and Detector	≥0.4 mm
Comparative Tracking Index per DIN IEC 112/VDE0 303, part 1	≥175
Isolation Resistance	
$V_{IO}=500 V, T_A=25^\circ C$	≥10 ¹² Ω
$V_{IO}=500 V, T_A=100^\circ C$	≥10 ¹¹ Ω
Storage Temperature Range	-55 to +150°C
Ambient Temperature Range	-55 to +100°C
Junction Temperature	100°C
Soldering Temperature (max. 10 s. Dip Soldering Distance to Seating Plane ≥1.5 mm)	260°C

Characteristics ($T_A=25^\circ\text{C}$)

Description	Symbol		Unit	Condition
Emitter (IR GaAs)				
Forward Voltage	V_F	1.25 (≤ 1.65)	V	$I_F=60\text{ mA}$
Reverse Current	I_R	0.01 (≤ 10)	μA	$V_R=6\text{ V}$
Capacitance	C_0	13	pF	$V_R=0\text{ V}$, $f=1\text{ MHz}$
Thermal Resistance	R_{thJA}	750	K/W	
Detector (Si Phototransistor)				
Capacitance	C_{CE}	5.2	pF	$V_{CE}=5\text{ V}$, $f=1\text{ MHz}$
Thermal Resistance	R_{thJA}	500	K/W	
Package				
Collector-Emitter Saturation Voltage	V_{CESAT}	0.25 (≤ 0.4)	V	$I_F=10\text{ mA}$, $I_C=2.5\text{ mA}$
Coupling Capacitance	C_C	0.4	pF	

Current Transfer Ratio (I_C/I_F at $V_{CE}=5\text{ V}$) and Collector-Emitter Leakage Current

Description	AA	AGB	AGR	
I_C/I_F ($I_F=5\text{ mA}$)	50–600	100–600	100–300	%
Collector-Emitter Leakage Current, I_{CEO} $V_{CE}=10\text{ V}$	10 (≤ 100)	10 (≤ 100)	10 (≤ 100)	nA

Switching Operation (with saturation)

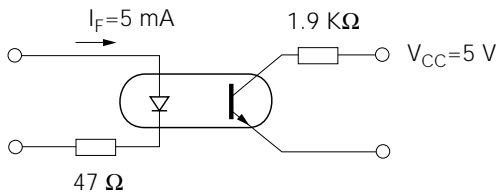

		$I_F=5\text{ mA}$	
Turn-on Time	t_{ON}	2.0	μs
Turn-off Time	t_{OFF}	25	μs

Figure 1. Current transfer ratio (typ.) vs. temperature
 $I_F=10\text{ mA}$, $V_{CE}=0.5\text{ V}$

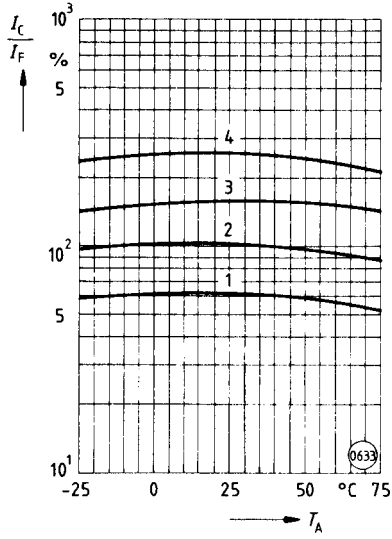

Figure 4. Transistor capacitance (typ.) vs. collector-emitter voltage
 $T_A=25^{\circ}\text{C}$, $f=1\text{ MHz}$

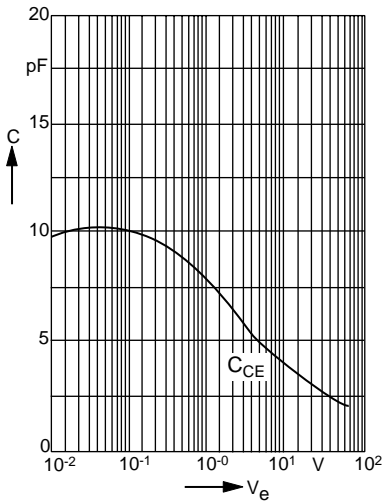

Figure 7. Permissible diode forward current vs. ambient temp.

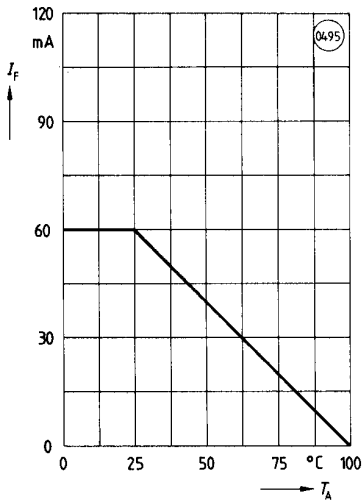

Figure 2. Output characteristics (typ.)
Collector current vs. collector-emitter voltage
 $T_A=25^{\circ}\text{C}$

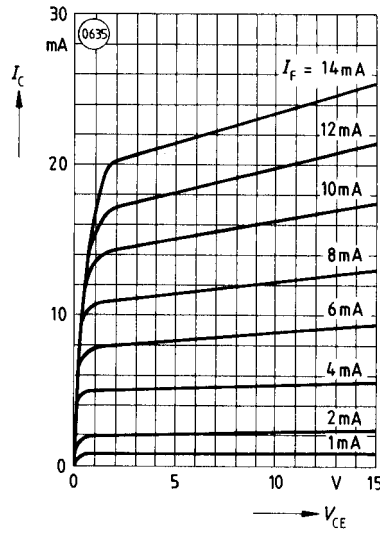

Figure 5. Permissible pulse handling capability. Fwd. current vs. pulse width
 Pulse cycle $D=\text{parameter}$, $T_A=25^{\circ}\text{C}$

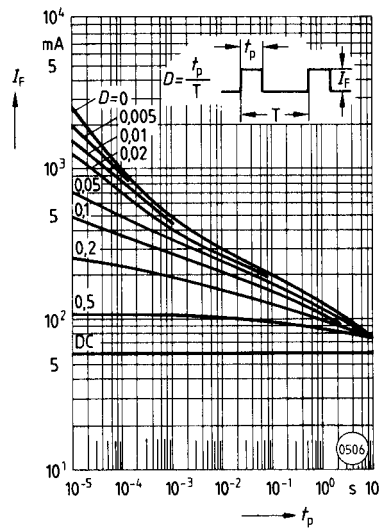

Figure 3. Diode forward voltage (typ.) vs. forward current

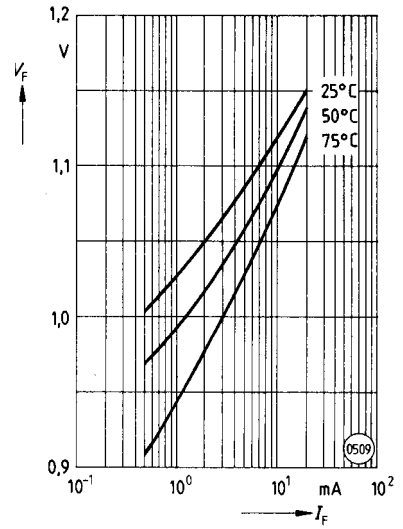

Figure 6. Permissible power dissipation vs. ambient temp.

