

CMOS 8-Bit Microcontroller
TMP88CH47N, TMP88CH47F

TMP88CH47N is high-speed and high-function 8-bit single-chip microcomputers whose built-in features include large-capacity RAM, multi-function timer/counter, and 10-bit AD converter, serial interface (UART/I²C bus). They are equipped with 3 phase brushless DC sensorless/sensor motor control, and AC motor inverter control.

Part No.	ROM	RAM	Package	OTP MCU
TMP88CH47N	16K bytes	512 bytes	P-SDIP42-600-1.78	TMP88PH47N
TMP88CH47F			P-QFP-1414-0.80D	TMP88PH47F

Features

- ◆ 8-bit single-chip microcomputer TLCS-870/X series microcomputer
- ◆ Interrupt sources: 23 (5 external, 18 Internal)
- ◆ I/O ports: 34 pins
 - Large-current output: 8 pins (typ. 20 mA), LED direct drive
- ◆ 16-bit timer/counter: 2 channels
 - Timer, event counter, programmable pulse generator (PPG) output, pulse width measurement, external trigger timer, window mode
- ◆ 8-bit Timer/Counter: 1 channel
 - Timer capture (pulse width measurement), programmable divider output (PDO) mode
- ◆ Time base timer (interrupt frequency: 1 to 16384 Hz)
- ◆ Watchdog timer
- ◆ Divider output function (frequency: 1 to 8 kHz)
- ◆ Programmable motor driver (PMD): 1 channel
 - Rotor position: minimum resolution of 250 ns for detecting rotor position
 - Motor control timer, timer capture function
 - Overload protection function
 - DC overload protection function
 - AC overload protection function (Can halt counter in 3-phase PWM output circuit)
 - Protection circuit for malfunction (urgent halt)
 - Automatic direction change, automatic position detection start
- ◆ Serial interface
 - 8-bit SIO/I²C bus
 - Universal asynchronous receiver transmitter (UART)
- ◆ 10-bit successive approximation type AD converter
 - Analog input: 8 channels
 - Conversion time: 11.5 μ s/46 μ s (at 16 MHz operation)
- ◆ Low power dissipation operation (2 modes)
 - STOP mode: Stops oscillation (battery or capacitor backup). Port output hold or high impedance selectable
 - IDLE mode: Stops CPU but continues operation of peripheral hardware. Released by interrupt (restarts CPU)
- ◆ Operating voltage: 4.5 to 5.5 V at 16 MHz operation

P-SDIP42-600-1.78

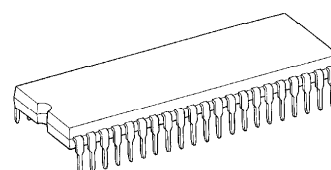
TMP88CH47N
TMP88PH47N

P-QFP44-1414-0.80D

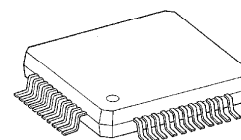
TMP88CH47F
TMP88PH47F

980910EBP2

- For a discussion of how the reliability of microcontrollers can be predicted, please refer to Section 1.3 of the chapter entitled Quality and Reliability Assurance/Handling Precautions.
- TOSHIBA is continually working to improve the quality and the reliability of its products. Nevertheless, semiconductor devices in general can malfunction or fail due to their inherent electrical sensitivity and vulnerability to physical stress. It is the responsibility of the buyer, when utilizing TOSHIBA products, to observe standards of safety, and to avoid situations in which a malfunction or failure of a TOSHIBA product could cause loss of human life, bodily injury or damage to property. In developing your designs, please ensure that TOSHIBA products are used within specified operating ranges as set forth in the most recent products specifications. Also, please keep in mind the precautions and conditions set forth in the TOSHIBA Semiconductor Reliability Handbook.
- The products described in this document are subject to the foreign exchange and foreign trade laws.
- The information contained herein is presented only as a guide for the applications of our products. No responsibility is assumed by TOSHIBA CORPORATION for any infringements of intellectual property or other rights of the third parties which may result from its use. No license is granted by implication or otherwise under any intellectual property or other rights of TOSHIBA CORPORATION or others.
- The information contained herein is subject to change without notice.



Purchase of TOSHIBA I²C components conveys a license under the Philips I²C Patent Rights to use these components in an I²C system, provided that the system conforms to the I²C Standard Specification as defined by Philips.

Pin Assignments

P-SDIP42-600-1.78

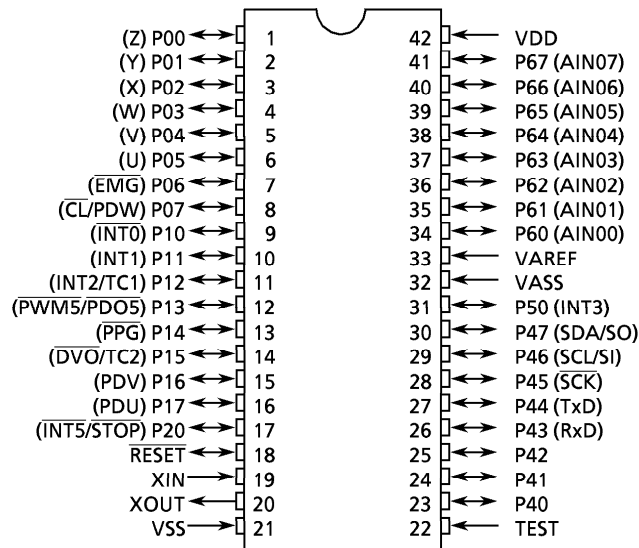

P-QFP44-1414-0.80D

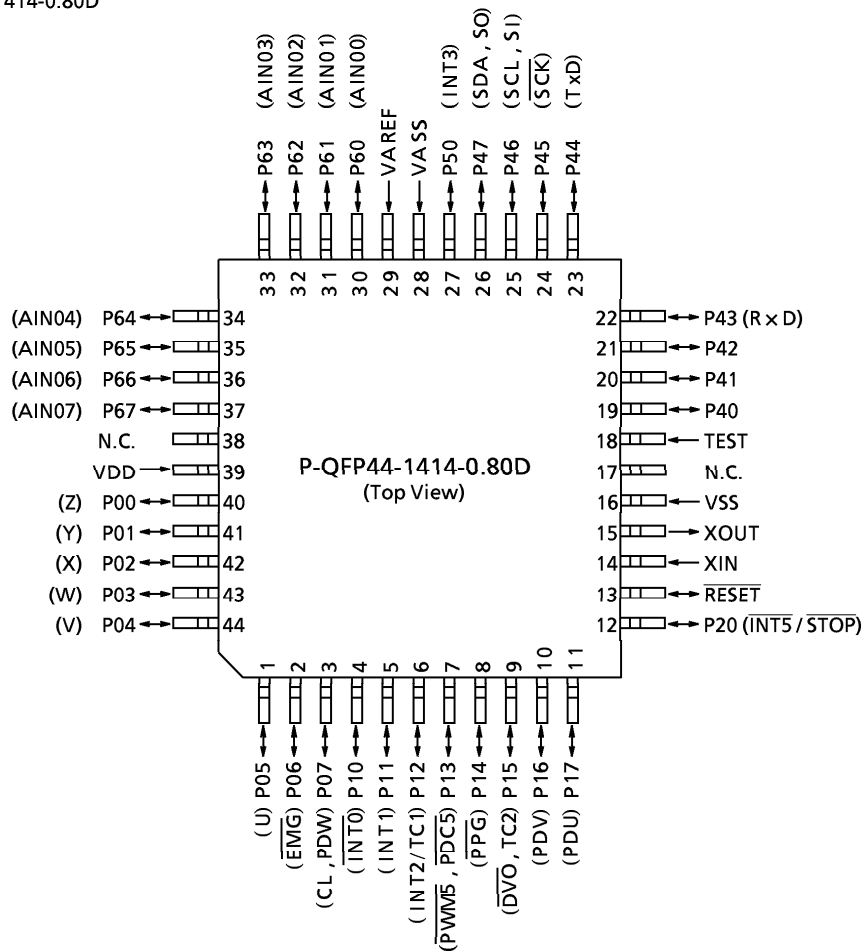

Block Diagram

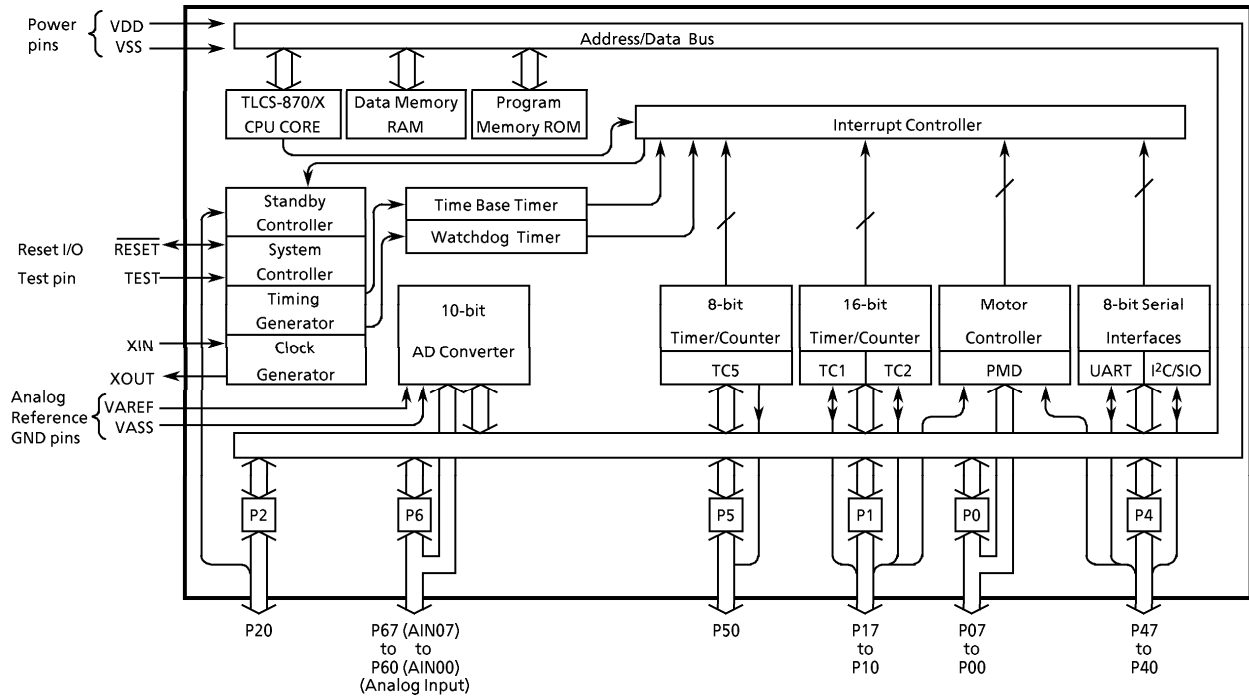

Pin Function

Pin Name	I/O	Function	
P07 (\overline{CL}/PDW)	I/O (Input)	8-bit programmable I/O port (tri state) Input or output specifiable in units of bits.	
P06 (\overline{EMG})		Overload protection input /motor control circuit W-phase position detection input	
P05 (U)		I/O (Output)	Motor control circuit malfunction detection input
P04 (V)			Motor control circuit U-/V-/W-phase output
P03 (W)			Motor control circuit X-/ Y-/Z-phase output
P02 (X)			
P01 (Y)		I/O (Output)	
P00 (Z)			
P17 (PDU)	I/O (Input)		8-bit programmable I/O port (tri state) Input or output specifiable units of bits.
P16 (PDV)			Motor control circuit U-phase position detection input
P15 ($\overline{DVO}/TC2$)	I/O (Output/Input)		When using pins for motor control circuit, timer/counter input, or external interrupt input, set them to input mode.
P14 (PPG)			Motor control circuit V-phase position detection input
P13 ($\overline{PWM5}/\overline{PDO5}$)			Divider output or Timer/Counter 2 input
P12 ($\overline{INT2}/TC1$)	I/O (Input)	When using pins for PPG output, divider output, or PWM output/PDO output, set them to output mode.	
P11 ($\overline{INT1}$)		Programmable pulse generator output	
P10 ($\overline{INT0}$)		PWM5 output/PDO5 output	
		External interrupt input 2 or Timer/Counter 1 input	
		External interrupt input 1	
		External interrupt input 0	

Pin Name	I/O	Function		
P20 ($\overline{\text{INT5/STOP}}$)	I/O (Input)	1-bit I/O port When using pins for input port, external interrupt input, or STOP mode release input, set output latches to 1.	External interrupt input 5 or STOP mode release signal input	
P47 (SDA/SO)	I/O (I/O/Output)	8-bit I/O port When using pins for motor control circuit input, UART/I ² C/SIO, set output latches to 1.	I ² C/SIO I/O	
P46 (SCL/SI)	I/O (I/O/Input)			
P45 (SCK)	I/O (I/O)			
P44 (TxD)	I/O (Input)			UART data input
P43 (RxD)	I/O (Output)			UART data output
P42	I/O			—
P41				—
P40		—		
P50 (INT3)	I/O (Input)	1-bit input/output port with latch. When using pins for input port, HPWM output, PWM output/PDO output, external interrupt input, or timer/counter input, set output latches to 1.	External interrupt 3 input	
P67 (AIN07) to P60 (AIN00)	I/O (Input)	8-bit programmable I/O port (tri state) Input or output specifiable in units of bits. When using pins for analog input, set to input mode using P6CR and ADCCR.	AD converter analog input	
XIN, XOUT	Input, Output	High-frequency oscillator connecting pins. For external clock input, input to XIN and leave XOUT open.		
$\overline{\text{RESET}}$	I/O	Reset signal input, watchdog timer output, address trap reset output, system clock reset output		
TEST	Input	Shipment test pin. Fix to "L" level.		
VDD, VSS	Power Supply	+ 5 V, 0 V (GND)		
VAREF, VASS		Analog reference voltage for AD conversion. Reference GND.		

Operation

1. CPU Core Functions

The CPU core consists of the CPU, system clock control circuit, and interrupt control circuit. This chapter describes the CPU core, program memory, data memory and the reset circuit.

1.1 Memory Address Map

The TMP88CH47 memory consists of four blocks : ROM, RAM, special function registers (SFR) and Data buffer registers (DBR). They are all mapped to a 1M-byte address space. Figure 1-1 shows the TMP88CH47 memory address map. There are 16 general-purpose registers mapped to the RAM address space.

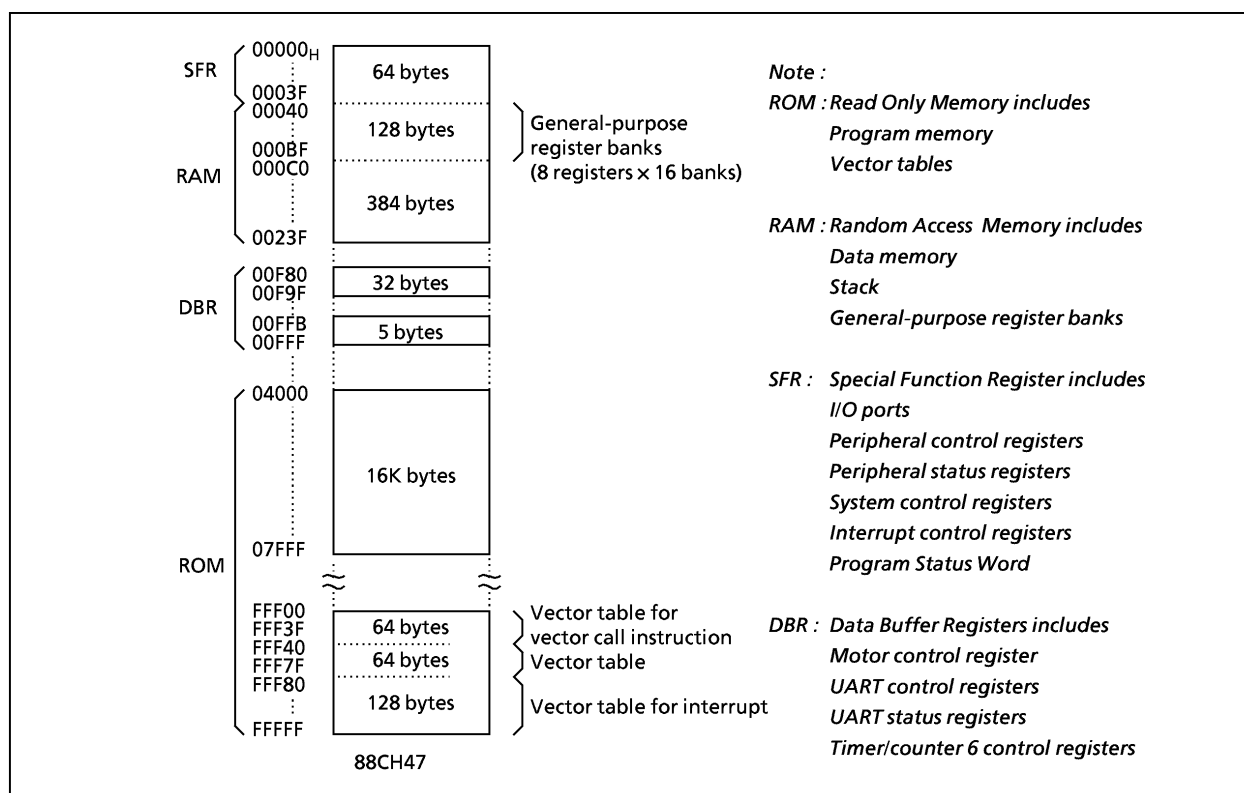

Figure 1-1. Memory Address Maps

1.2 Program Memory (ROM)

TMP88CH47 contains a 16K-byte program memory (mask ROM) at addresses from 04000 to 07FFF_H. In addition, contains a 256-byte program memory (mask ROM) at addresses from FFF00 to FFFFF_H.

Electrical Characteristics

Absolute Maximum Ratings		(V _{SS} = 0 V)		
Parameter	Symbol	Pins	Ratings	Unit
Supply Voltage	V _{DD}		- 0.3 to 6.5	V
Input Voltage	V _{IN}		- 0.3 to V _{DD} + 0.3	V
Output Voltage	V _{OUT1}	Port P21, P22, $\overline{\text{RESET}}$, Tri-state port	- 0.3 to V _{DD} + 0.3	V
	V _{OUT2}	Port P20, Sink open drain port	- 0.3 to 5.5	V
Output Current	I _{OUT1}	Ports P1, P2, P4, P5, P6	3.2	mA
	I _{OUT2}	Port P0	20	
Output Current	ΣI_{OUT1}	Ports P1, P2, P4, P5, P6	120	mA
	ΣI_{OUT2}	Port P0	60	
Power Dissipation [Topr = 70°C]	PD	TMP88CH47	600	mW
Soldering Temperature (time)	Tsld		260 (10 s)	°C
Storage Temperature	Tstg		- 55 to 125	°C
Operating Temperature	Topr		- 40 to 85	°C

Note: The absolute maximum ratings are rated values which must not be exceeded during operation, even for an instant. Any one of the ratings must not be exceeded. If any absolute maximum rating is exceeded, a device may break down or its performance may be degraded, causing it to catch fire or explode resulting in injury to the user. Thus, when designing products which include this device, ensure that no absolute maximum rating value will ever be exceeded.

Recommended Operating Conditions		(V _{SS} = 0 V, Topr = - 40 to 85°C)					
Parameter	Symbol	Pins	Conditions	Min	Max	Unit	
Supply Voltage	V _{DD}		fc =	4.5	5.5	V	
			16 MHz				NORMAL mode
							IDLE mode
Input High Voltage	V _{IH1}	Except hysteresis input	V _{DD} ≥ 4.5 V	V _{DD} × 0.70	V _{DD}	V	
	V _{IH2}	Hysteresis input					
	V _{IH3}		V _{DD} < 4.5 V	V _{DD} × 0.90			
Input Low Voltage	V _{IL1}	Except hysteresis input	V _{DD} ≥ 4.5 V	0	V _{DD} × 0.30	V	
	V _{IL2}	Hysteresis input			V _{DD} × 0.25		
	V _{IL3}		V _{DD} < 4.5 V		V _{DD} × 0.10		
Clock Frequency	fc	XIN, XOUT	V _{DD} = 4.5 to 5.5 V	8.0	16.0	MHz	

Note 1: The recommended operating conditions for a device are operating conditions under which it can be guaranteed that the device will operate as specified. If the device is used under operating conditions other than the recommended operating conditions (supply voltage, operating temperature range, specified AC/DC values etc.), malfunction may occur. Thus, when designing products which include this device, ensure that the recommended operating conditions for the device are always adhered to.

Note 2: Clock frequency fc: The condition of supply voltage range is the value in NORMAL and IDLE modes.

D.C. Characteristics

(V_{SS} = 0 V, T_{opr} = -40 to 85°C)

Parameter	Symbol	Pins	Conditions	Min	Typ.	Max	Unit
Hysteresis Voltage	V _{HS}	Hysteresis inputs		-	0.9	-	V
Input Current	I _{IN1}	TEST	V _{DD} = 5.5 V V _{IN} = 5.5 V/0 V	-	-	± 2	μA
	I _{IN2}	Sink open drain, Tri-state ports					
	I _{IN3}	RESET, STOP					
Input Resistor (*)	R _{IN}	TEST with pull-down		20	70	170	kΩ
	R _{IN}	RESET		90	220	510	
Output Leakage Current	I _{OL}	Sink open drain, Tri-state ports	V _{DD} = 5.5 V, V _{OUT} = 5.5 V/0 V	-	-	± 2	μA
Output High Voltage	V _{OH}	Tri-state ports	V _{DD} = 4.5 V, I _{OH} = -0.7 mA	4.1	-	-	V
Output Low Current	I _{OL1}	Except XOUT, Ports P0	V _{DD} = 4.5 V, V _{OL} = 0.4 V	-	1.6	-	mA
	I _{OL2}	Port P0	V _{DD} = 4.5 V, V _{OL} = 1.0 V	-	10	-	
Supply Current in NORMAL Mode			V _{DD} = 5.5 V V _{IN} = 5.3 V/0.2 V f _c = 16.0 MHz	-	20	32	mA
Supply Current in IDLE Mode				-	10	16	mA
Supply Current in STOP Mode			V _{DD} = 5.5 V V _{IN} = 5.3 V/0.2 V	-	0.5	20	μA

Note 1: Typical values show those at T_{opr} = 25°C, V_{DD} = 5 V.

Note 2: Input Current I_{IN1}, I_{IN3}: The current through resistor is not included, when the input resistor (pull-up or pull-down) is contained.

Note 3: I_{DD} except I_{REF}.

AD Conversion Characteristics

(T_{opr} = -40 to 85°C)

Parameter	Symbol	Conditions	Min	Typ.	Max			Unit
					ADCDR1	ADCDR2		
						ACK = 0	ACK = 1	
Analog Reference Voltage	V _{AREF}	V _{AREF} - V _{ASS} ≥ 3.5 V	V _{DD} - 1.0	-	V _{DD}			V
	V _{ASS}		V _{SS}	-	1.0			
Analog Input Voltage	V _{AIN}		V _{ASS}	-	V _{AREF}			V
Analog Supply Current	I _{REF}	V _{AREF} = 5.5 V, V _{ASS} = 0.0 V	-	0.5	1.0			mA
Non-Linearity Error		V _{DD} = 5.0 V, V _{SS} = 0.0 V V _{AREF} = 5.000 V V _{ASS} = 0.000 V	-	-	± 1	± 3	± 2	LSB
Zero Point Error			-	-	± 1	± 3	± 2	
Full Scale Error			-	-	± 1	± 3	± 2	
Total Error			-	-	± 2	± 6	± 4	

Note 1: ADCDR1: 8-bit AD conversion result (1LSB = ΔV_{AREF}/256)

ADCDR2: 10-bit AD conversion result (1LSB = ΔV_{AREF}/1024)

Note 2: Total error includes all errors except quantization error.

A.C. Characteristics (V_{SS} = 0 V, V_{DD} = 4.5 to 5.5 V, Topr = - 40 to 85°C)

Parameter	Symbol	Conditions	Min	Typ.	Max	Unit
Machine Cycle Time	t _{cy}	NORMAL mode	0.25	-	0.5	μs
		IDLE mode				
"H" Level Clock Pulse Width	t _{WCH}	For external clock operation (XIN input)	31.25	-	62.5	ns
"L" Level Clock Pulse Width	t _{WCL}					

Recommended Oscillating Conditions (V_{SS} = 0 V, V_{DD} = 4.5 to 5.5 V, Topr = - 40 to 85°C)

Parameter	Oscillator	Oscillation Frequency	Recommended Oscillator	Recommended Constant	
				C ₁	C ₂
High-frequency Oscillation	Ceramic Resonator	16 MHz	MURATA CSA16.00 MXZ	5pF	5pF
			MURATA CST16.00 MXW	built-in 5pF	built-in 5pF

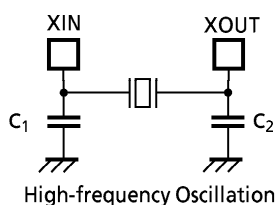

Note: An electrical shield by metal shield on the surface of IC package should be recommendable in order to prevent the device from the high electric fieldstress applied from CRT (Cathode Ray Tube) for continuous reliable operation.