

**MOTOROLA****SEMICONDUCTORS**

P.O. BOX 20912 • PHOENIX, ARIZONA 85036

MR2520L
MR2525L**OVERVOLTAGE TRANSIENT SUPPRESSORS**

... designed for applications requiring a diode with reverse avalanche characteristics for use as reverse power transient suppressors. Developed to suppress transients in the automotive system, these devices operate in the forward mode as standard rectifiers or reverse mode as power zener diodes and will protect expensive mobile transceivers, radios and tape decks from over-voltage conditions.

- High Power Capability
- Economical
- Increased Capacity by Parallel Operation

OVERVOLTAGE TRANSIENT SUPPRESSORS**2.5K-10K WATTS****MAXIMUM RATINGS**

Rating	Symbol	Value	Unit
DC Peak Repetitive Reverse Voltage Working Peak Reverse Voltage DC Blocking Voltage	V_{RRM} V_{RWM} V_R	23	Volts
Repetitive Peak Reverse Surge Current MR2520L MR2525L (Time Constant = 10 ms, Duty Cycle \leq 1.0%, $T_C = 25^\circ\text{C}$)	I_{RSM}	68 110	Amp
Operating and Storage Junction Temperature Range	T_J, T_{stg}	-65 to +175	$^\circ\text{C}$

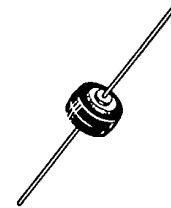
**ELECTRICAL CHARACTERISTICS**

Characteristic	Symbol	Min	Max	Unit
Reverse Current ($V_R = 20 \text{ Vdc}$, $T_C = 25^\circ\text{C}$) ($V_R = 20 \text{ Vdc}$, $T_C = 100^\circ\text{C}$)	I_R	—	50 300	$\mu\text{A dc}$
Breakdown Voltage ($I_R = 100 \text{ mA dc}$, $T_C = 25^\circ\text{C}$)	$V_{(BR)}$	24	32	Volts
Breakdown Voltage (1) MR2525L only ($I_R = 40 \text{ Amp}$, $T_C = 85^\circ\text{C}$)	$V_{(BR)}$	—	40	Volts

(1) Pulse Test: Pulse Width \leq 10 ms, Duty Cycle \leq 2.0%.**THERMAL CHARACTERISTICS**

Characteristic	Lead Length	Symbol	Max	Unit
Thermal Resistance, Junction to Lead @ Both Leads to Heat Sink, Equal Length	1/4" 3/8" 1/2"	$R_{\theta JL}$	7.5 10 13	$^\circ\text{C/W}$

(1) Pulse Test: Pulse Width \leq 10 ms, Duty Cycle \leq 2.0%.**MECHANICAL CHARACTERISTICS:**

CASE: Transfer Molded Plastic

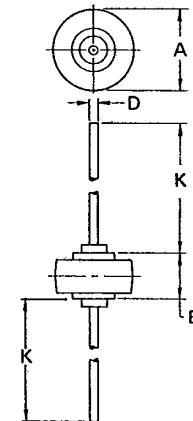
MAXIMUM LEAD TEMPERATURE FOR SOLDERING PURPOSES: 350 $^\circ\text{C}$ 3/8"
from case for 10 seconds at 5 lbs. tension**FINISH:** All external surfaces are corrosion-resistant, leads are readily solderable**POLARITY:** Indicated by diode symbol or cathode band**WEIGHT:** 2.5 Grams (approx.)

DIM	MILLIMETERS		INCHES	
	MIN	MAX	MIN	MAX
A	10.03	10.29	0.395	0.405
B	5.94	6.25	0.234	0.246
D	1.27	1.35	0.050	0.053
K	25.15	25.65	0.990	1.010

CASE 194-01
(MR2525L)

DIM	MILLIMETERS		INCHES	
	MIN	MAX	MIN	MAX
A	8.43	8.68	0.332	0.342
B	5.94	6.25	0.234	0.246
D	1.27	1.35	0.050	0.053
K	25.15	25.65	0.990	1.010

CASE 194-05
(MR2520L)

REVERSE SURGE DESIGN LIMITS

FIGURE 1 — PEAK CURRENT

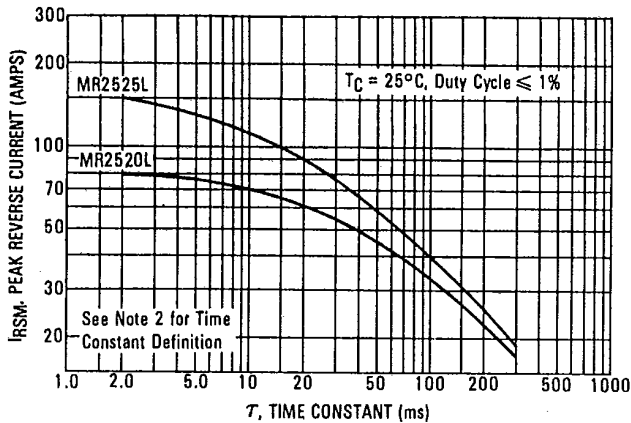

FIGURE 2 — PEAK POWER

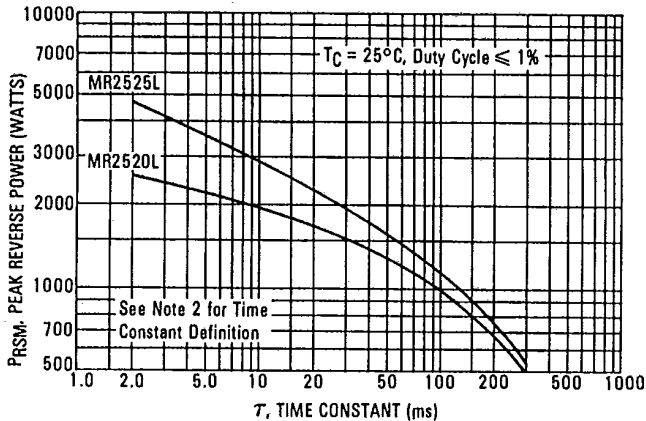
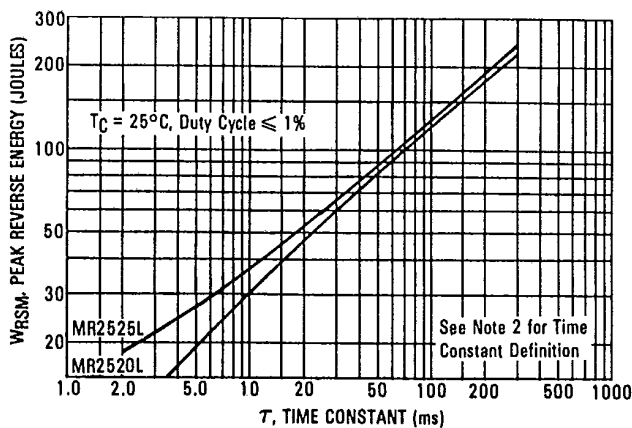

FIGURE 3 — ENERGY



NOTE 1 — TRANSIENTS IN THE AUTOMOTIVE ELECTRICAL SYSTEM

The introduction of electronics into the automobile has brought with it the interesting sidelight of characterizing the automotive electrical system for transients.

Since most electro-mechanical systems exhibit a wear-out phenomenon as electrical stresses are increased, there has been no need to separately define transients from the normal load conditions. Any transient condition was simply accounted for by increasing contact ratings, etc. The introduction of semiconductors changes the picture since they exhibit a different sensitivity to transients. Semiconductors tend to have a black and white failure characteristic when exposed to transients in that no damage is caused below a certain level and total failure results above a certain level. Unfortunately these two levels are separate and the problem is further complicated by the fact that the energy tolerance of semiconductors is normally subject to a production distribution. This leaves solid state systems open to problems which are discovered only after many units are in the field.

SUMMARY OF TRANSIENTS

Transients in the automotive electrical system have widely varying energy levels occurring over widely varying times, but most become insignificant compared to the worst transient known as "Load Dump". Load dump happens when the battery becomes disconnected while the alternator is supplying charging current, or the disconnection of some other load with no battery present. Load dump transients generally are of 200 to 500 milliseconds duration, having an exponential decay from a worst case peak voltage of 80-120 volts. A clamped load dump, it should be noted, will be of considerably shorter duration.

Although the possibility of the battery becoming disconnected while the engine is running may seem remote, it is not reasonable this occurrence should result in the total failure of the electrical system of a car.

The following table lists some of the transients the automotive electronic designer must consider and should cause him to provide some level of protection.

Power Source	Available Transients
Battery Line	1. ± 200 Volts for microseconds 2. +Load Dump
Ignition Line and Accessory Line	1. -300 Volts for milliseconds 2. ± 200 Volts for microseconds 3. +Load Dump

Note: All transients are exponential decay.

The voltages and times shown are reasonable values from many on-car measurements. Since the nonload-dump transients are of low energy, but high voltage, it is recommended they be clamped rather than blocked. It is imperative that source impedances also be known to allow proper selection of clamp devices.



STOPPING THE TRANSIENTS AT THE SOURCE

Figure 4 shows the most straight forward method of preventing large negative transients from disrupting the accessory and ignition busses. At the instant the switch is opened, the current flowing in the inductance will transfer to the diode producing about 1 volt negative on that particular buss. This condition will remain until the current in the inductance decays at a rate determined by the L/R time constant for the circuit. It can be shown that the peak currents and transient durations available in the car can easily be absorbed by a 1N4003 diode.

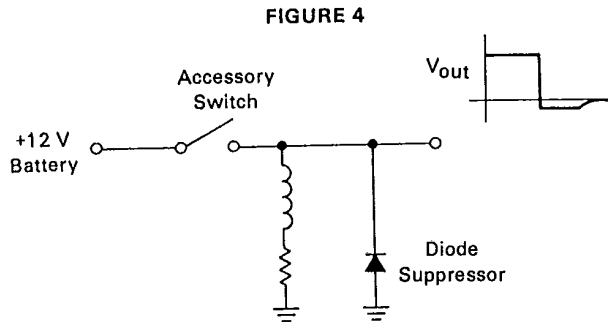
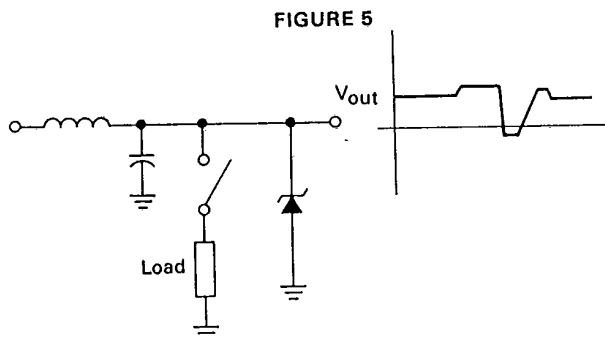
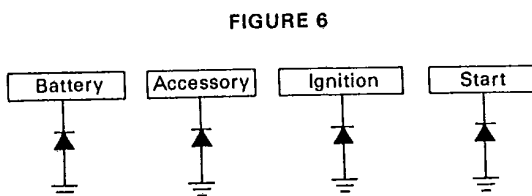

Figure 5 shows the most straight forward scheme for protecting against the series L-C type of transient. The forward biased diode action to protect the negative transient is similar to the action described for Figure 4. An avalanche device is required to clip off the positive portion.

Just applying these two techniques and calling the result a master suppressor, overlooks the result of mutual coupling. Because of this effect, it becomes apparent that



protecting against positive inductive transients at one spot is useless. Using the technique shown in Figure 5 to protect the various lines, would not be money well spent, since the same level of protection would still be required at each module anyway, due to mutual coupling. The best central suppressor for negative transients, then, is shown in Figure 6.



To complete the job, protection is needed against load dump. The easiest method is to simply clamp the output of the alternator with an avalanche device, as shown in Figure 7. The completed suppressor would then appear as in Figure 8. It could easily be more cost effective to incorporate the load dump suppressor into the alternator itself. The end effect would be identical to Figure 7,

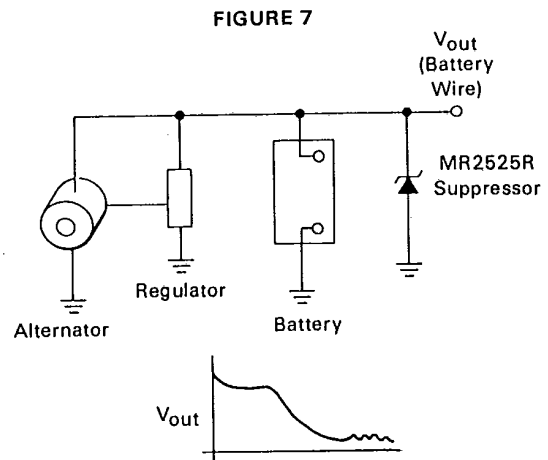

however, the implementation would require placing 3 avalanche devices in place of the present 3 diodes in the ground side of the diode bridge in the alternator.

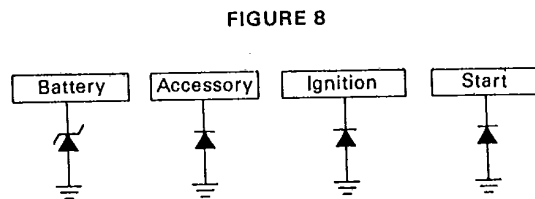

REVERSE BATTERY

Installing a battery with the terminals reversed today causes total failure of the charging system. Usually a fuse link fails, however, some cars suffer alternator failure. This condition is caused by a large current in-rush through the diode bridge which is forward biased during reverse battery condition. The master suppressor proposed in Figure 8 will suffer the same fate. While a suppressor can easily be devised, which will not drain current during -12V condition, it is apparent that this defeats the purpose of the suppressor. In order to make this concept feasible, a circuit breaker must be inserted in series with the main battery lead.

PARALLEL OPERATION

Higher surge current capabilities can be obtained by paralleling the basic suppressor cells. Contact Motorola Semiconductor Products Division through the nearest sales office or authorized distributor for more information on number of cells required and package configurations available.



FIGURE 9 — STEADY STATE THERMAL RESISTANCE

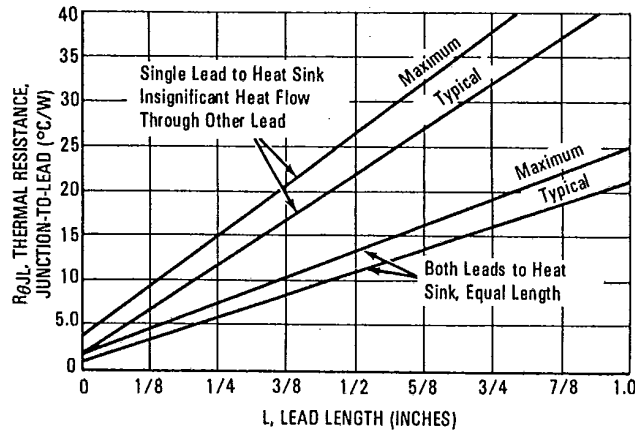
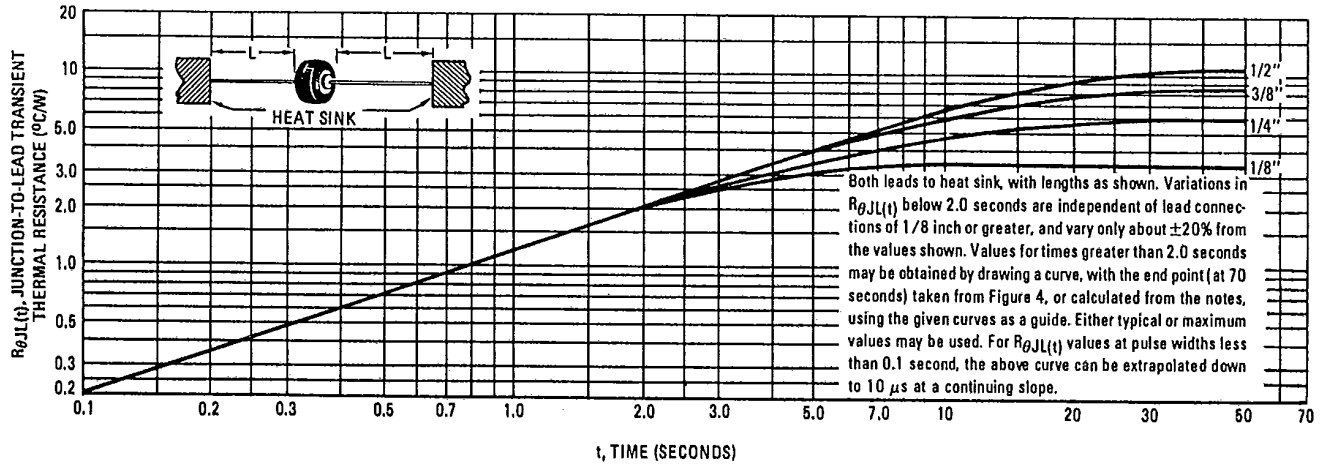
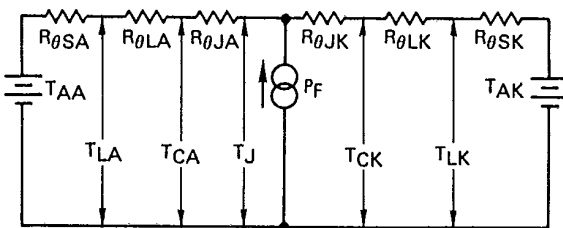

FIGURE 10 — TYPICAL TRANSIENT THERMAL RESPONSE



THERMAL CIRCUIT MODEL
(For Heat Conduction Through The Leads)



Use of the above model permits junction to lead thermal resistance for any mounting configuration to be found. Lowest values occur when one side of the rectifier is brought as close as possible to the heat sink as shown below. Terms in the model signify:

- T_A = Ambient Temperature
- $R_{\theta S}$ = Thermal Resistance, Heat Sink to Ambient
- T_L = Lead Temperature
- $R_{\theta L}$ = Thermal Resistance, Lead to Heat Sink
- T_C = Case Temperature
- $R_{\theta J}$ = Thermal Resistance, Junction to Case
- T_J = Junction Temperature
- P_D = Power Dissipation (Subscripts A and K refer to anode and cathode sides respectively.)

Values for thermal resistance components are:
 $R_{\theta L} = 40^\circ\text{C/W/IN}$. Typically and 44°C/W/IN Maximum
 $R_{\theta J} = 2^\circ\text{C/W}$ Typically and 4°C/W Maximum

Since $R_{\theta J}$ is so low, measurements of the case temperature, T_C will be approximately equal to junction temperature in practical lead mounted applications. When used as a 60 Hz rectifier, the slow thermal response holds $T_{J(PK)}$ close to $T_{J(AVG)}$. Therefore maximum lead temperature may be found from:
 $T_L = 175^\circ\text{C} - R_{\theta JL} P_D$.

The recommended method of mounting to a PC board is shown on the sketch, where $R_{\theta JA}$ is approximately 25°C/W for a $1\text{-}1/2'' \times 1\text{-}1/2''$ copper surface area. Values of 40°C/W are typical for mounting to terminal strips or PC boards when available surface area is small.

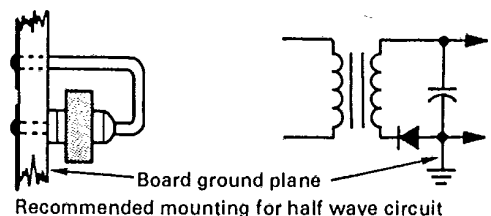

NOTE 2 — METHOD FOR CALCULATING ENERGY DISSIPATED IN A SURGE SUPPRESSOR DURING CAPACITIVE DISCHARGE TESTS

One of the major parameters of interest in the rating of a diode surge suppressor is the energy dissipated in the device during an exponentially decaying transient pulse. Surge suppressor diodes are usually characterized using a capacitive discharge test, as shown in Figures 11 and 12. Calculation of the energy, peak power and the R-C time constant of the capacitive discharge power pulse is described in the material that follows and correlates with both of the circuits.

EMPIRICAL PARAMETER DETERMINATION

Figure 13 shows the instantaneous current and voltage applied to the DUT as obtained with a dual trace memory oscilloscope during pulse testing using the circuit of Figure 11. Points on the instantaneous power curve can be found by multiplying the instantaneous current by the instantaneous voltage at various points in time.

From equation (1): $p(t) = P_m e^{-t/\tau}$ (4)

FIGURE 11 — AUTOMOTIVE LOAD DUMP TEST CIRCUIT

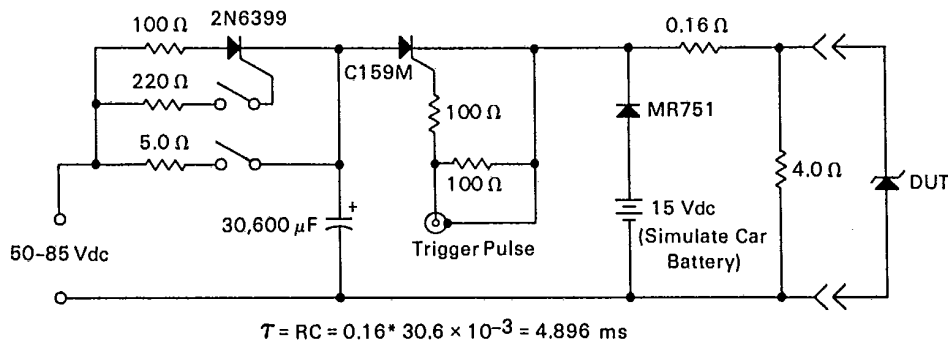
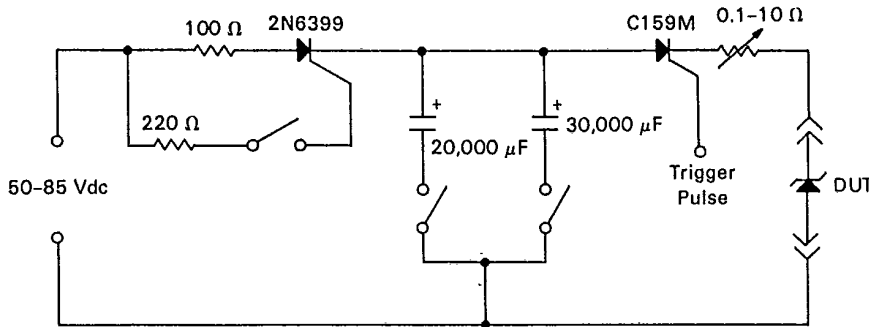

FIGURE 12 — CAPACITIVE DISCHARGE TEST CIRCUIT



THEORETICAL ENERGY CALCULATION

Assuming that the instantaneous power dissipated in the DUT (Diode Under Test) can be represented as an exponential decay represented by

$p(t) = P_m e^{-t/\tau}$ (1)

where P_m is the peak power at $t = 0$ and τ is the R-C time constant of the test circuit, then the energy dissipated in the DUT can be calculated as:

$W = \int_0^{\infty} P_m e^{-t/\tau} dt$ (2)

$\therefore W = \tau P_m$ (3)

Empirical determination of P_m and τ will allow calculation of the energy in the pulse using expression (3) above.

FIGURE 13 — REPRESENTATION OF CURRENT AND VOLTAGE APPLIED TO TEST DIODE

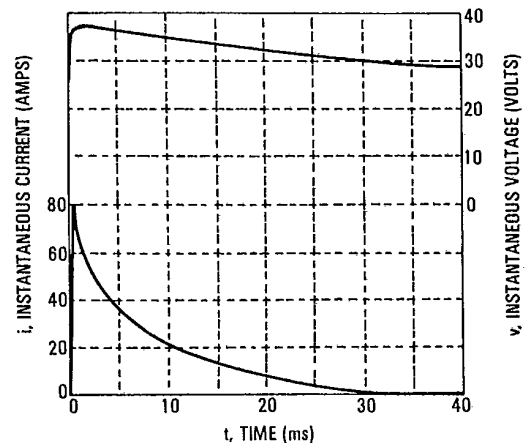

$$\text{thus, } \ln p(t) = \ln P_m - \frac{t}{\tau} \quad (5)$$

Calculation of $p(t)$ and $\ln p(t)$ using data points off Figure 3 tabulates as follows:

t (ms)	v(t) (Volts)	i(t) (Amps)	p(t) (Watts)	ln p(t)
0.5	36.0	80.0	2880	7.965
1.5	37.5	54.0	2025	7.613
2.5	37.0	50.0	1850	7.523
3.5	36.5	42.0	1533	7.335
4.5	36.0	38.0	1368	7.221
9.5	34.5	22.0	759	6.632
19.5	32.0	8.0	256	5.545
29.5	30.0	2.0	60	4.094

Expression (5) is the equation form for a straight line

$$y = mx + b \quad (6)$$

Where m is the slope and b is the intercept

For expression (5) $\frac{-1}{\tau}$ is the slope and $\ln P_m$ is the intercept

$$\text{thus, } \tau = \frac{-1}{m} \quad (7)$$

$$P_m = \ln^{-1}(b) \quad (8)$$

Accurately fitting a straight line to the $\ln p(t)$ vs. t data points allows determination of P_m and τ for use in equation (3).

REGRESSION APPROACH

The method of least squares can be used to determine the slope and intercept of the line which best fits the data points $\ln p(t)$ vs. t calculated above. Least squares regression routines are available on most time sharing computer systems as well as on many scientific calculators.

A least squares regression for the above data points shows the intercept and slope to be 7.8588 and -0.12429 respectively, and from (6) and (7).

$$P_m = \ln^{-1}(b) = \ln^{-1}(7.8588) = 2588.4 \text{ Watts}$$

$$\tau = \frac{-1}{m} = \frac{-1}{-0.12429} = 8.046 \text{ ms}$$

Finally, the energy dissipated in the DUT is:

$$W = \tau P_m = 20.825 \text{ Joules}$$

The multiple correlation coefficient of the regression for this example was 0.994 indicating a 99.4% accuracy of the fit to the theoretical equation (1). In general, accuracies above 97% can be obtained.

SUMMARY:

The energy dissipated in a diode in a capacitive discharge test can be calculated from data obtained from a dual trace memory oscilloscope using the following procedure:

1. Record the current and voltage pulses simultaneously on a dual trace memory oscilloscope using appropriate scales to utilize the entire scope to display the decay.
2. Pick off approximately five voltage and current data points across the decay (do not use $t = 0$ as a data point since the voltage across the DUT is initially very low, the current is at its peak and the energy dissipated is negligible).
3. Multiply these instantaneous current and voltage values and take the natural logarithm of the product.
4. Perform a least squares regression of $\ln p(t)$ vs. t to determine the slope and intercept of the "best fitting" straight line. The R^2 (correlation coefficient) should be above 90% for good accuracy.
5. Calculate τ and P_m using equations (7) and (8).
6. Calculate the energy using equation (3).

COMMENTS:

Using this method, the time constant derived will be slightly larger than the R-C product of the capacitor and resistor used in the circuit. This occurs due to the series resistance of the DUT and the Thyristor in the firing circuit. The peak energy calculated from this method will be less than what is indicated by the current and voltage traces at $t = 0$. This difference is of little consequence, however, because of the short duration during which it exists. In the example used, the current and voltage at $t = 0$ are 100 A and 30 Volts. These conditions exist for 0.5 ms or less and thus the energy dissipated is less than 1.5 Joules or 7% of the calculated energy. This 7% difference is a typical value.

Perhaps more accuracy could be obtained by adding 7% to the calculated energy, however, without the 7% "adder" this method can be used as a comparison of different transient suppressors.

Motorola reserves the right to make changes without further notice to any products herein to improve reliability, function or design. Motorola does not assume any liability arising out of the application or use of any product or circuit described herein; neither does it convey any license under its patent rights nor the rights of others. Motorola and  are registered trademarks of Motorola, Inc. Motorola, Inc. is an Equal Employment Opportunity/Affirmative Action Employer.



MOTOROLA Semiconductor Products Inc.

BOX 20912 • PHOENIX, ARIZONA 85036 • A SUBSIDIARY OF MOTOROLA INC.