

MAXIM

MAX1846 Evaluation Kit

General Description

The MAX1846 evaluation kit (EV kit) contains both the MAX1846 and MAX1847. Both devices are inverting, current-mode, constant-frequency PWM controllers. The MAX1846 circuit is configured for a +12V input and a -5V output at 2A. The MAX1847 circuit is configured for a +3.3V input and a -12V output at 400mA. Each circuit is powered separately so there is no interaction between the two circuits. The MAX1846 is available in a 10-pin μ MAX package and the MAX1847 is available in a 16-pin QSOP package.

The MAX1846 EV kit is a fully assembled and tested surface-mount circuit board. With minimal modification, it can also be used to evaluate other output voltages.

Features

- ◆ 3V to 16.5V Input Range
- ◆ MAX1846 Circuit Configured for +12V Into -5V at 2A
- ◆ MAX1847 Circuit Configured for +3.3V Into -12V at 400mA
- ◆ Evaluates Both the MAX1846 and MAX1847 Independently
- ◆ Fully Assembled and Tested

Ordering Information

PART	TEMP RANGE	IC PACKAGE
MAX1846EVKIT	-40°C to +85°C	10 μ MAX 16 QSOP

Component List

DESIGNATION	QTY	DESCRIPTION
C1, C11	2	0.47 μ F \pm 10%, 25V, X7R ceramic capacitors (0805) Murata GRM40X7R474K025AL
C2, C3, C4	3	22 μ F \pm 20%, 10V, X5R ceramic capacitors (1812) Taiyo Yuden LMK432BJ226MM
C5	1	0.22 μ F \pm 10%, 25V, X7R ceramic capacitor (0805) Murata GRM40X7R224K025AL
C6, C16	2	220pF \pm 10%, 50V COG ceramic capacitors (0805) Murata GRM40COG221K050AL
C7, C8	2	47 μ F \pm 20%, 16V POSCAPs Sanyo 16TPB47M
C9, C19	2	0.1 μ F \pm 10%, 50V, X7R ceramic capacitors (0805) Taiyo Yuden UMK212BJ104KG
C10	1	1200pF \pm 10%, 50V COG ceramic capacitor (0805) Murata GRM40COG122K050AL
C12, C13, C14	3	10 μ F \pm 20%, 25V, X5R ceramic capacitors (1812) Taiyo Yuden TMK432BJ106MM
C15	1	0.047 μ F \pm 10%, 25V, X7R ceramic capacitor (0805) Murata GRM40X7R473K025AL

DESIGNATION	QTY	DESCRIPTION
C17, C18	2	100 μ F \pm 20%, 10V POSCAPs Sanyo 10TPB100M
C20	1	390pF \pm 10%, 50V COG ceramic capacitor (0805) Murata GRM40COG391K050AL
C21, C22	2	1000pF \pm 10%, 50V COG ceramic capacitors (0805) Murata GRM40COG102K050AL
D1, D2	2	5A, 40V Schottky diodes (SMC) Central Semiconductor CSMH5-40
JU1, JU2	2	Jumpers, SIP3, 3-pin headers
JU1, JU2	2	Shunts
L1, L2	2	10 μ H, 10A power inductors Coilcraft DO5022P-103 or Coiltronics UP4B-100
P1	1	-8.0A, -20V P-channel MOSFET Fairchild FDS6375 (SO-8)
P2	1	-8.8A, -30V P-channel MOSFET Fairchild FDS6685 (SO-8)
R1	1	0 Ω \pm 5% resistor (0805)
R2, R9	2	22k Ω \pm 5% resistors (0805)
R3	1	10k Ω \pm 5% resistor (0805)
R4, R11	2	150k Ω \pm 5% resistors (0805)

Evaluates: MAX1846/MAX1847

MAX1846 Evaluation Kit

Component List (continued)

DESIGNATION	QTY	DESCRIPTION
R5, R12	2	20mΩ 1W ±1% sense resistors (2512) Dale WSL-2512-R020-F
R6	1	95.3kΩ ±1% resistor (0805)
R7, R14	2	10kΩ ±1% resistors (0805)
R8	1	Not installed (0805)
R10	1	8.2kΩ ±5% resistor (0805)
R13	1	40.2kΩ ±1% resistor (0805)
R15, R16	2	100Ω ±5% resistors (0805)
U1	1	MAX1847 (16-pin QSOP)
U2	1	MAX1846 (10-pin μMAX)
None	1	MAX1846 data sheet
None	1	MAX1846 EV kit data sheet

Quick Start

The MAX1846 EV kit is fully assembled and tested. Follow these steps to verify board operation.

Do not turn on the power supply until all connections are completed.

MAX1847 Output (-12V)

- 1) Verify that a shunt is across pins 1 and 2 of jumper JU1 (SHDN).
- 2) Verify that a shunt is across pins 2 and 3 of jumper JU2 (SYNC).
- 3) Connect a voltmeter to the VOUT pad.
- 4) Preset a 3V to 5.5V DC power supply to 3V. Turn off power supply. This power supply should be able to supply 3A continuous current.
- 5) Connect the power supply to the VIN pad. Connect the supply ground to the GND pad.
- 6) Connect a load up to 400mA between VOUT and GND.
- 7) Turn on the power supply and gradually increase the input voltage through the 3V to 5.5V range.
- 8) Verify that VOUT is -12V throughout the +3V to +5.5V input voltage range.

Component Suppliers

SUPPLIER	COMPONENT	PHONE	WEBSITE
AVX	Capacitors	803-946-0690	www.avxcorp.com
Central Semiconductor	Diodes	516-435-1110	www.centralsemi.com
Coilcraft	Inductors	847-639-6400	www.coilcraft.com
Coiltronics (Cooper)	Inductors	561-752-5000	www.cooperet.com
Dale	Resistors	402-564-3131	www.vishay.com/brands/dale/main.html
Fairchild	MOSFETs	408-721-2181	www.fairchildsemi.com
International Rectifier	MOSFETs	310-322-3331	www.irf.com
IRC	Resistors	512-992-7900	www.irctt.com
Kemet	Capacitors	864-963-6300	www.kemet.com
Murata	Capacitors	770-436-1300	www.murata.com
Panasonic	Capacitors Resistors	201-348-7522	www.panasonic.com
Sanyo	Capacitors	619-661-6835	www.secc.co.jp
Sprague	Capacitors	603-224-1961	www.vishay.com/brands/sprague/main.html
Sumida	Inductors	847-956-0666	www.remtechcorp.com
Taiyo Yuden	Capacitors	800-368-2496	www.t-yuden.com
Vitramon	Resistors	203-268-6261	www.vishay.com/brands/vitramon/main/html

MAX1846 Evaluation Kit

MAX1846 Output (-5V)

- 1) Connect a voltmeter to the VOUT1 pad.
- 2) Connect a “turned off” 12.0V DC power supply to the VIN1 pad. This power supply should be able to supply 2A continuous current.
- 3) Connect the supply ground to the GND pad.
- 4) Connect a load up to 2A between VOUT1 and GND.
- 5) Turn on the power supply and verify that VOUT1 is -5V.

Detailed Description

The MAX1846 EV kit contains two high-efficiency, PWM inverting controllers. The MAX1846 is configured to convert a +12V input to a -5V output and is capable of delivering up to 2A of current. The MAX1847 is configured to convert a +3V to +5.5V input to -12V and will deliver in excess of 400mA depending on the input voltage. Both devices are inverting, current-mode, constant-frequency PWM controllers capable of operating at frequencies from 100kHz to 500kHz with a simple resistor change (R4 and R11). The EV board is configured to operate at 300kHz. Note that for optimum efficiency and stability, other components may need to be optimized, depending on the operating frequency selected. Refer to the MAX1846/MAX1847 data sheet for more information. The MAX1847 can be synchronized to an external clock signal in the same frequency range and also has a shutdown feature. The MAX1846

is in an ultra-compact 10-pin μ MAX package and the MAX1847 is in a 16-pin QSOP package.

Jumper Selection

Shutdown Mode

The MAX1847 features a shutdown mode that reduces quiescent current. The 3-pin jumper (JU1) selects the shutdown mode for the MAX1847. To enable the MAX1847 shutdown mode, connect pins 2 and 3 on JU1 with the supplied shunt. For normal operation, connect pins 1 and 2.

Synchronized Mode

The MAX1847 features a synchronized mode that enables the operating frequency to be controlled by an external clock. To utilize the synchronized mode, remove the shunt on jumper JU2 connecting pins 2 and 3 and place it on pins 1 and 2. Connect an external frequency source to the SYNC pad. The external frequency source must be a TTL level and have a 20% to 80% duty cycle.

Note: The value of R4 must program an internal oscillator frequency lower than the frequency of the external clock. Refer to the MAX1846/MAX1847 data sheet for more information.

MAX1846 Evaluation Kit

Evaluates: MAX1846/MAX1847

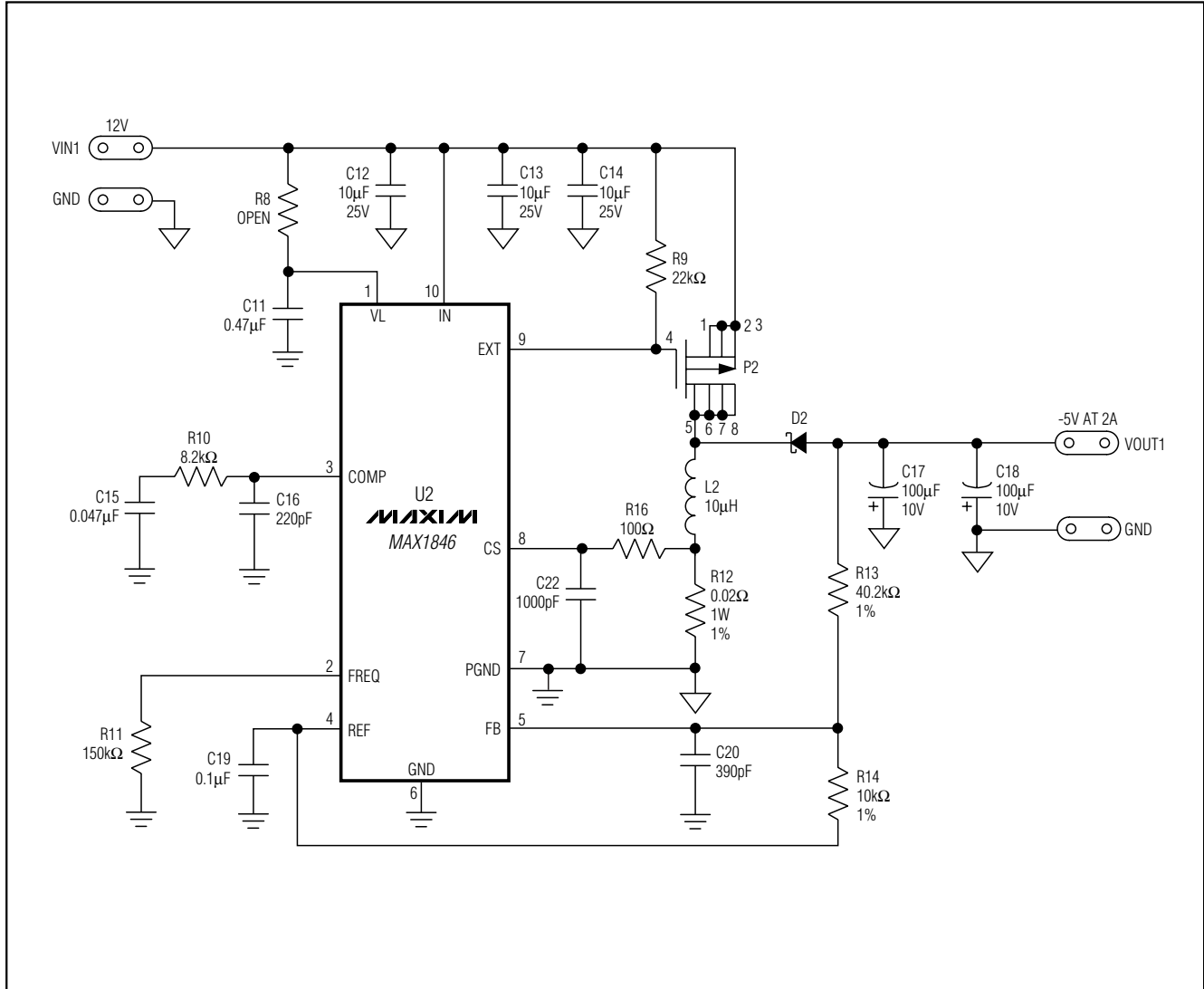

Figure 1. MAX1846 EV Kit Schematic

MAX1846 Evaluation Kit

Evaluates: MAX1846/MAX1847

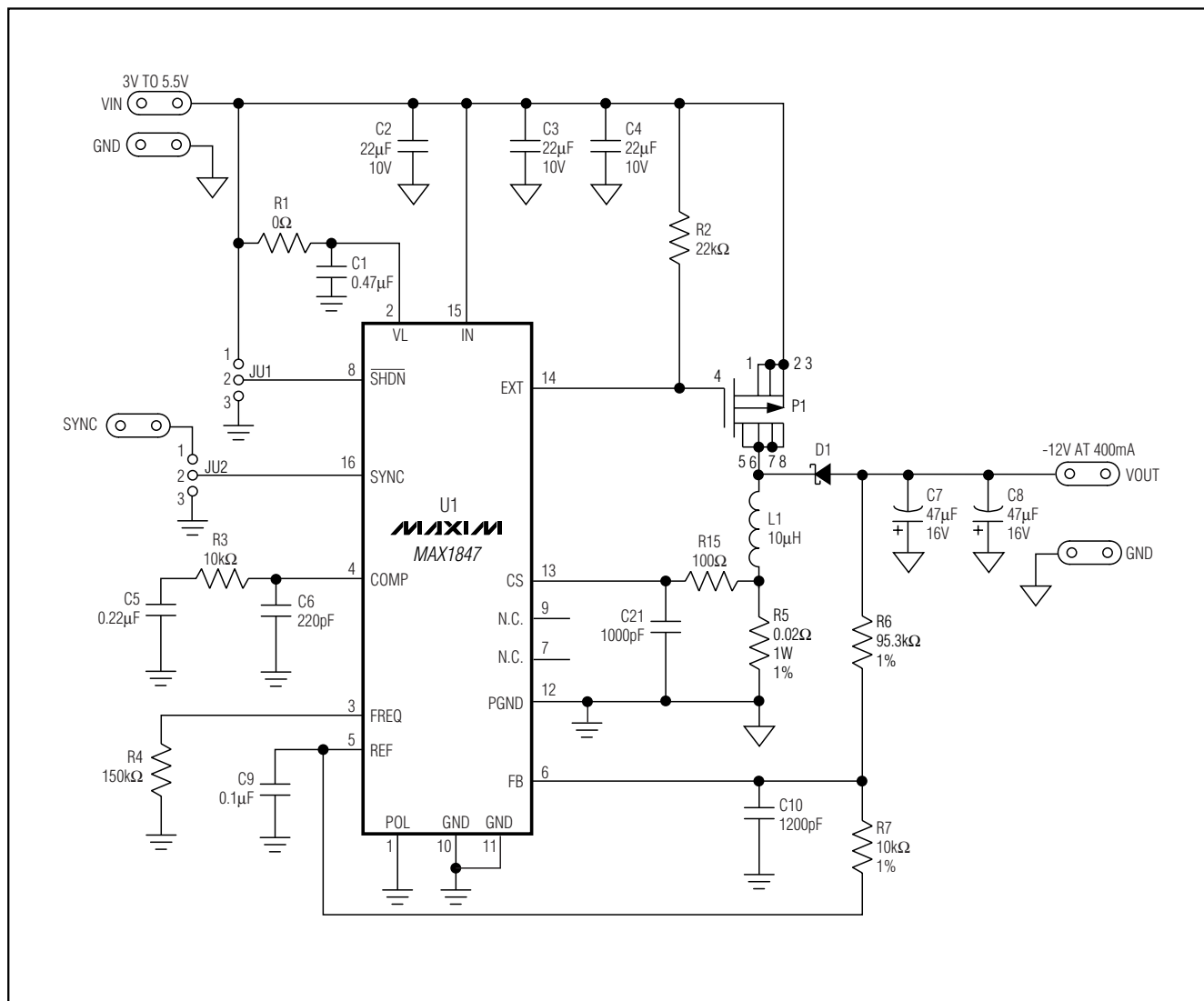

Figure 2. MAX1847 EV Kit Schematic

MAX1846 Evaluation Kit

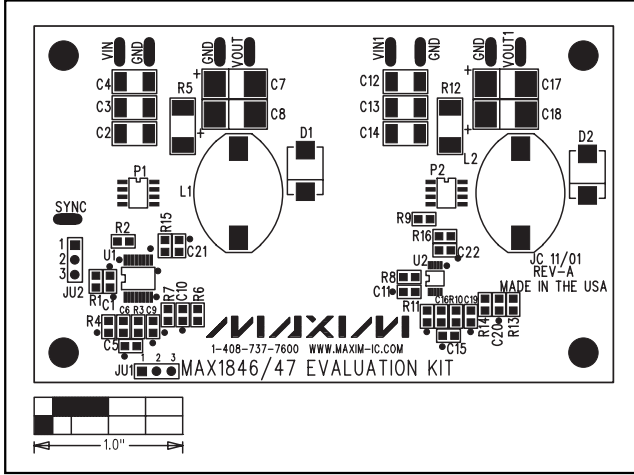

Figure 3. MAX1846 EV Kit Component Placement Guide—Component Side

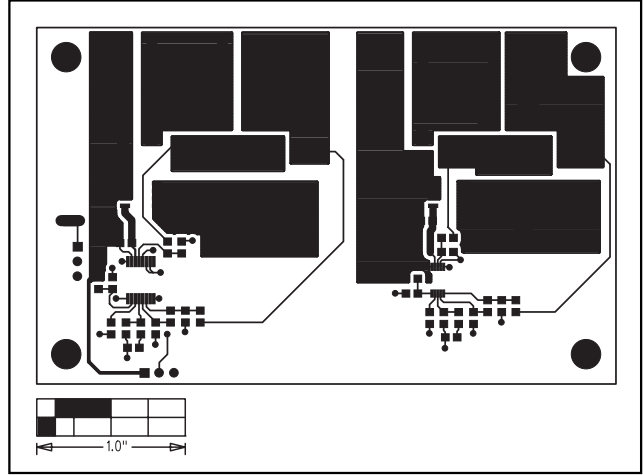

Figure 4. MAX1846 EV Kit PC Board Layout—Component Side

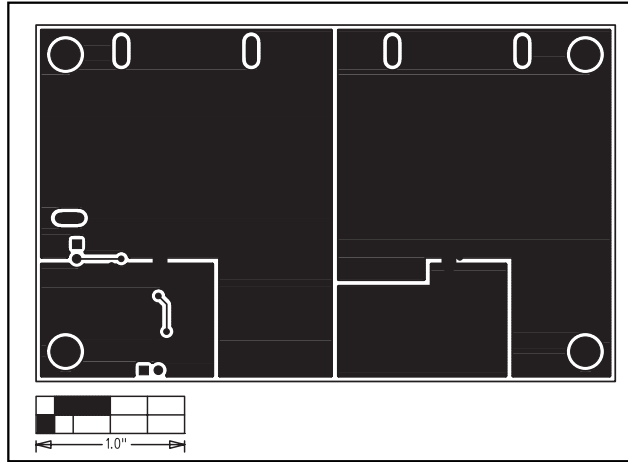

Figure 5. MAX1846 EV Kit PC Board Layout—Solder Side

Maxim cannot assume responsibility for use of any circuitry other than circuitry entirely embodied in a Maxim product. No circuit patent licenses are implied. Maxim reserves the right to change the circuitry and specifications without notice at any time.

6 _____ **Maxim Integrated Products, 120 San Gabriel Drive, Sunnyvale, CA 94086 408-737-7600**