

## Full Color LED Controller Driver with PWM Control

### ■ GENERAL DESCRIPTION

The **NJU6061** is a full color LED controller driver. It can control and drive a 3 in 1 packaged (Red, Green and Blue) LED.

The **NJU6061** contains PWM luminance (Pulse Width Modulation) control circuit, LED driving circuit, MPU interface and so on.

The PWM signal control the duty cycle of each RGB LED delicately, therefore can realize a lot of colors.

The Sweep Operation function can simplify the LED brightness control.

The Brightness Correction function can fake a linear change of the LED brightness in human eyes.

Enable terminal (ON/OFF) is possible to synchronize with a sound source etc.

It requires only four external components such as three resistors for LED current adjustment and one for oscillation, which enables the **NJU6061** to save PCB space.

The **NJU6061** can be cascaded and controlled at the same time.

**NJU6061** is suitable for cellular phone, car audio and so on.

### ■ PACKAGE OUTLINE

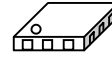

**NJU6061PB1**

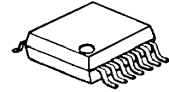

**NJU6061V**

### ■ FEATURES

- Controlling a 3-in-1 packaged RGB LED      ILED=30mA x 3
- Built-in PWM luminance control              16 steps x 3 (Internal 128 steps x 3)
- Built-in 8bit serial interface circuit
- Cascade connect
- Sweep operation function
- Brightness correction
- Built-in oscillation circuit
- Operating voltage                                1.7V to 5.5V
- Package    FFP12(2.0\*2.0\*0.85mm), SSOP14
- CMOS Technology

# NJU6061

## PIN CONNECTIONS (TOP VIEW)

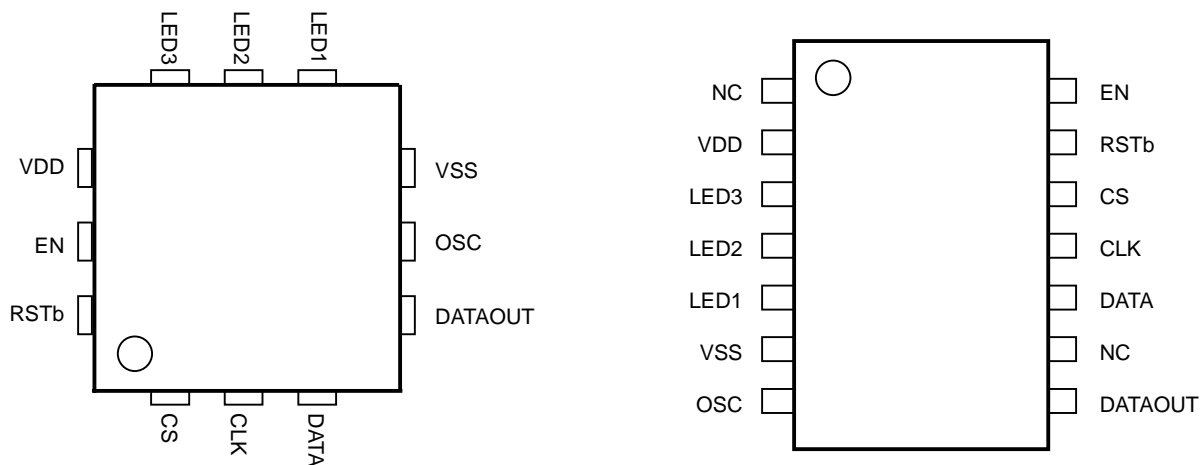

## PIN DESCRIPTIONS

PIN No.		PIN NAME	TYPE	DESCRIPTIONS
FFP12	SSOP14			
1	12	CS	Input	Chip Select terminal When CS terminal is "L", the DATA terminal is in output state. At the rising edge of CS signal, if CLK="H", the DATA terminal is in input state. The serial data is latched on at the falling edge of CS clock.
2	11	CLK	Input	Shift Clock terminal
3	10	DATA	Input / Output	Serial Data terminal
4	8	DATAOUT	Output	Serial Data Output terminal (for cascade connection)
5	7	OSC	Input	Oscillating terminal Connecting a External resistor
6	6	V <sub>SS</sub>	Power	Ground terminal
7	5	LED1	Output	LED Connect terminals (Open drain output) Output level can be divided into 16 steps by PWM signal. Connecting with the cathode of LED.
8	4	LED2	Output	
9	3	LED3	Output	
10	2	V <sub>DD</sub>	Power	V <sub>DD</sub> Power Supply terminal
11	14	EN	Input	Enable terminal "H" : LED ON "L" : LED OFF
12	13	RSTb	Input	Reset terminal - Active "L".
-	1,9	NC		Non Connect These terminals are electrically open.

## ■ BLOCK DIAGRAM

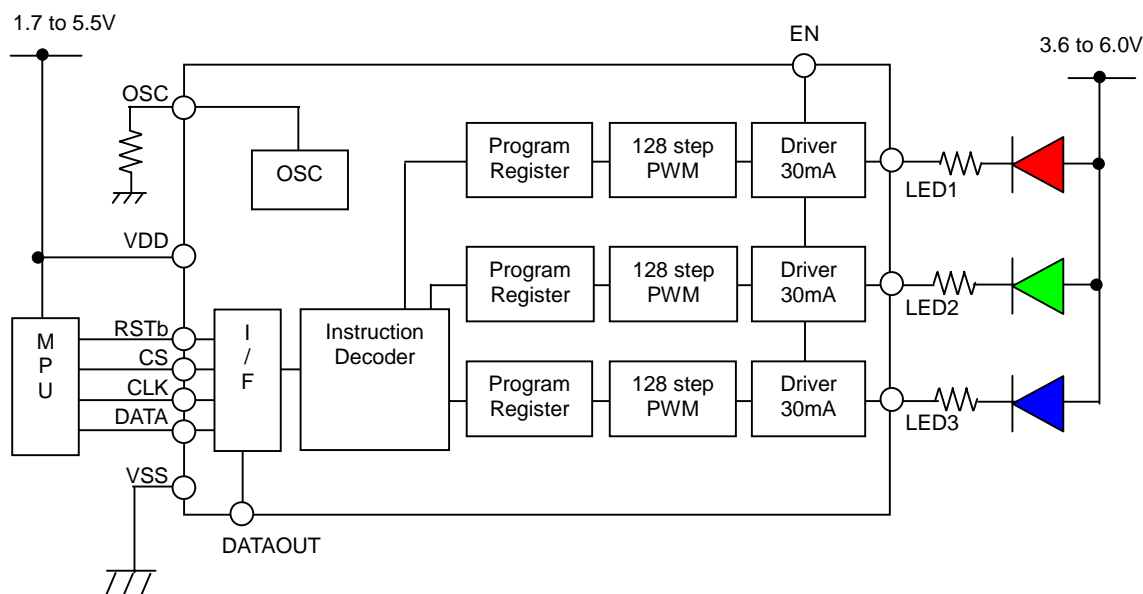

## ■ FUNCTIONAL DESCRIPTIONS

### (1) Description for Each Blocks

#### (1-1) PWM Luminance Control

The **NJU6061** incorporates three 128 steps PWM Luminance Control circuits.

The relationship between PWM duty cycle and the register value is shown as below:

REGISTER	DUTY	REGISTER	DUTY
0,0,0,0	0/128	1,0,0,0	27/128
0,0,0,1	1/128	1,0,0,1	36/128
0,0,1,0	2/128	1,0,1,0	46/128
0,0,1,1	3/128	1,0,1,1	59/128
0,1,0,0	5/128	1,1,0,0	73/128
0,1,0,1	8/128	1,1,0,1	90/128
0,1,1,0	13/128	1,1,1,0	108/128
0,1,1,1	19/128	1,1,1,1	128/128

#### (1-2) Oscillator

The oscillation circuit with the external register generates the clock signal for PWM. The PWM frequency ( $f_{PWM}$ ) can be finely adjusted by the external resistor. In addition, the oscillation circuit can be turned on/off by the instruction to minimize the current consumption.

If not zero PWM signal is still output after the oscillation circuit OFF, write 0/128 (0,0,0,0) into the register or let EN = "L".

#### (1-3) Enable function

The enable terminal (EN terminal) is used to turn on/off the device from the external. The register value does not change by this signal. When EN terminal is not used, connect this terminal to  $V_{DD}$ .

## (1-4) Brightness Correction

Even if the change of the brightness of LED is linear, human eyes receive a curve change. The built-in brightness correction function can rectify the difference between actual LED luminance and its appearance.

According to the following compensation curve, 16 steps are selected from 128 steps PWM. And the nonlinear luminance characteristic of LED is rectified so that it becomes linear by appearance.

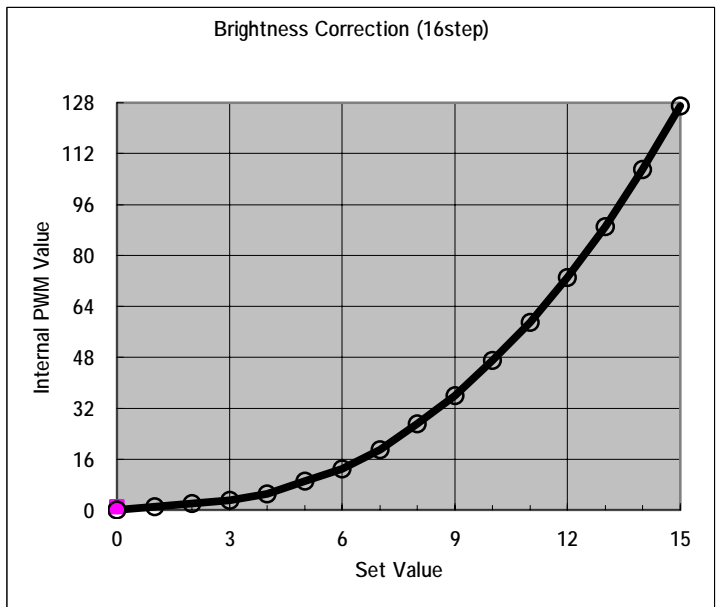

The sequency of PWM set: (Not use Sweep Function)

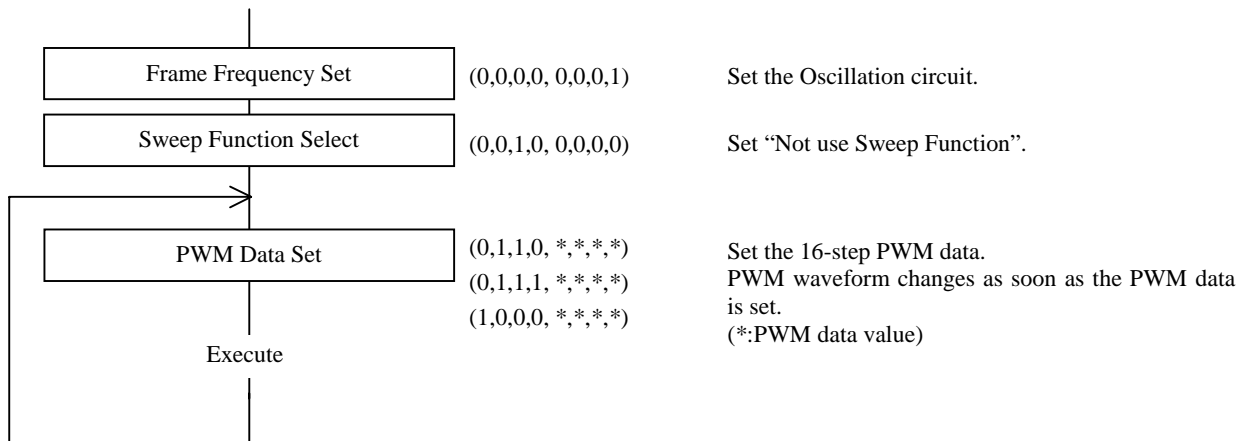

By staggering the output waveforms' phases, allowable dissipation of LED package can be reduced.  
 The LED brightness can be selected from 16 levels (0 to 15) by Brightness Correction function.

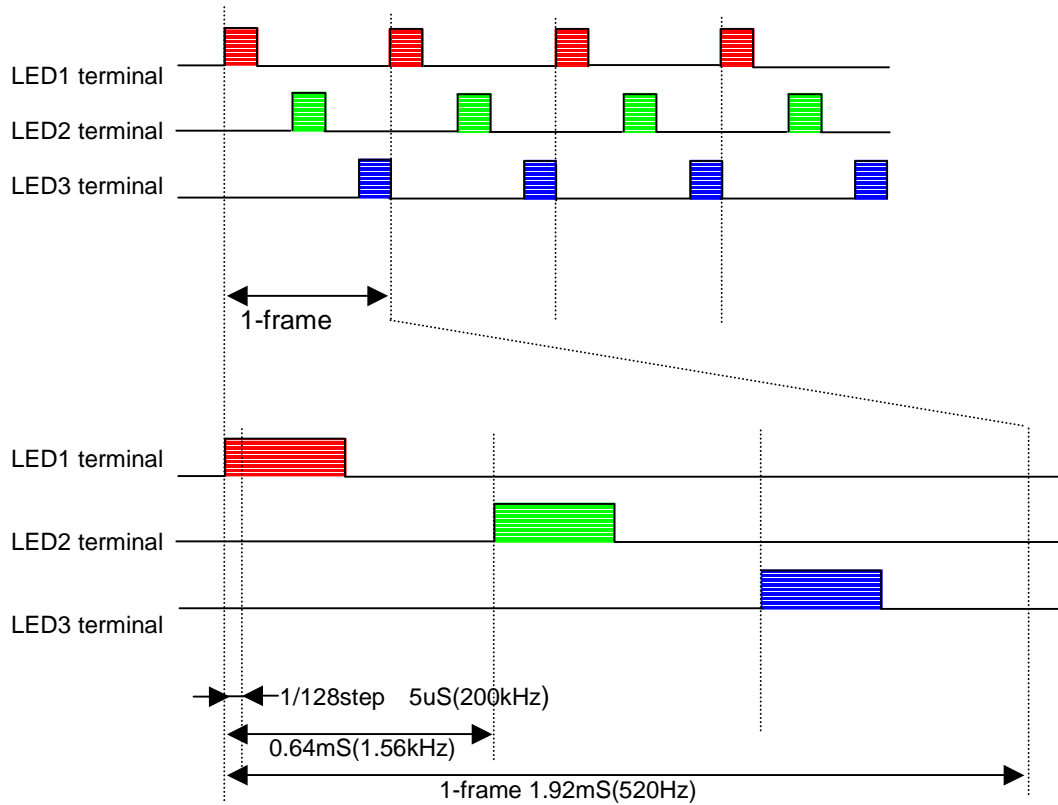

fosc=400kHz,  
 Frame Frequency Set D<sub>1</sub>=0

## (1-5) Sweep Function

The Sweep Function allows a smooth color-changing of RGB LEDs.

By setting up the initial value, counter number, sweep direction and stepping time, adjusted PWM data can realize a smoothly color-changing.

At the end of the program, the NJU6061 will send request signal to CPU and the DATA pin is pulled low, PWM value at the last count will be maintained and outputted.

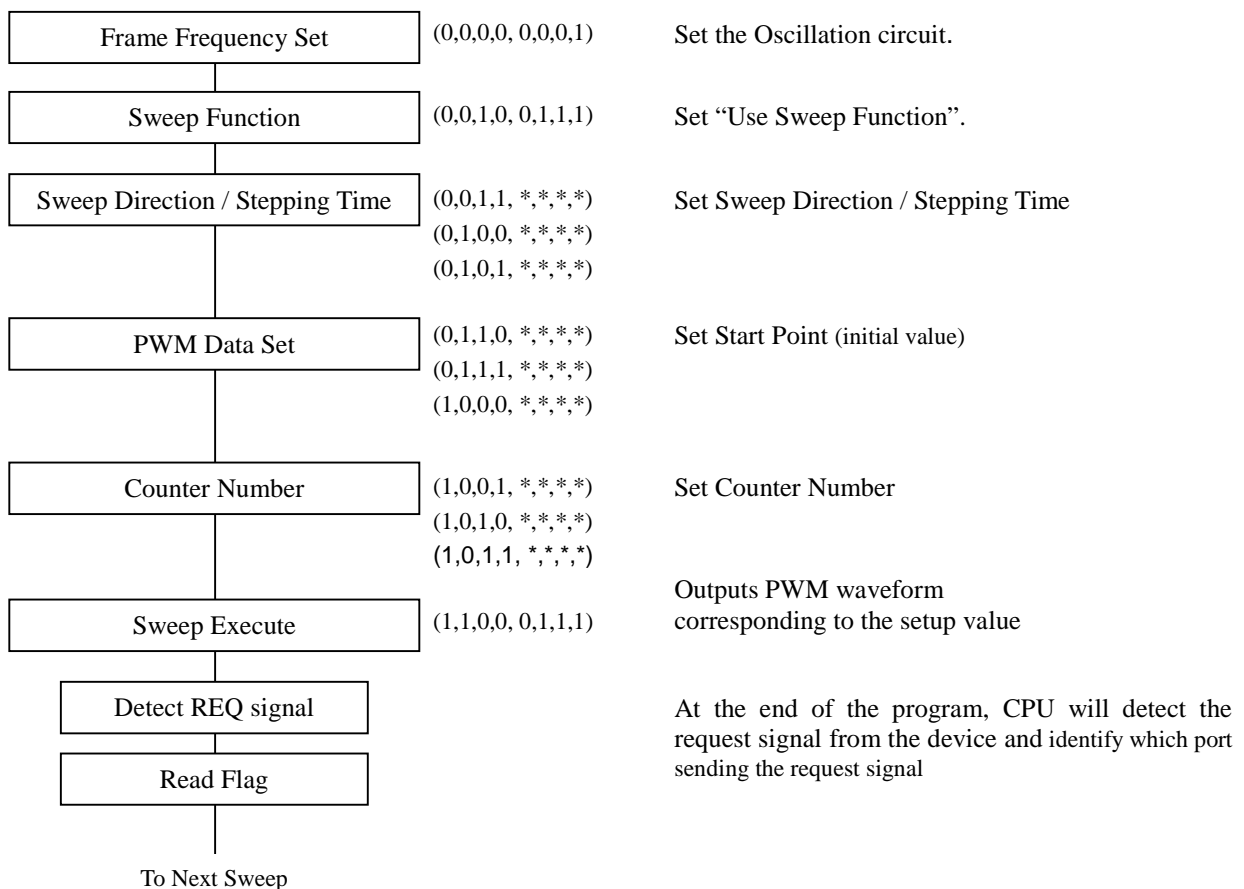
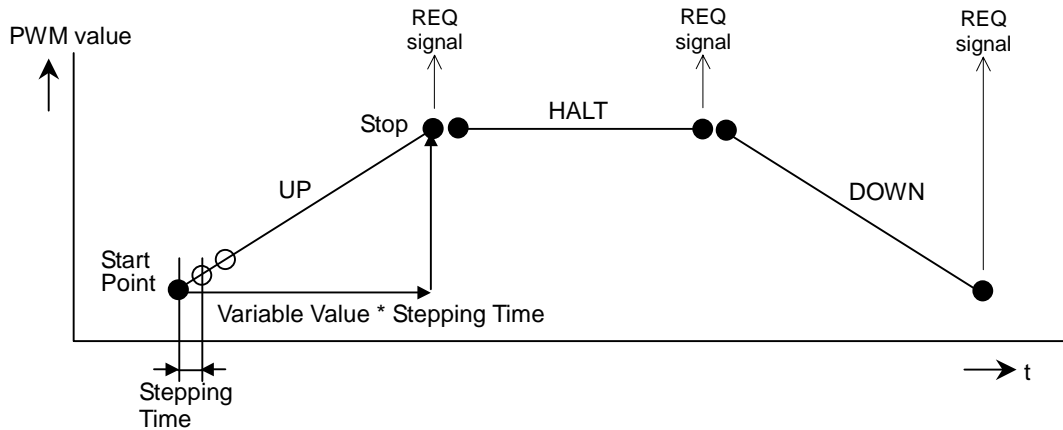

(2) Instructions

The data transfer between CPU and **NJU6061** is via a 3-wire serial interface.

Synchronized with CLK, the input data is latched on at the falling edge of CS signal, The MSB (D) is first.

Table.1 shows the instruction codes of the **NJU6061**.

Table 1. Instruction Code

Instruction		Code								Description
		D7	D6	D5	D4	D3	D2	D1	D0	
a	NOP	0	0	0	0	*	*	*	*	Non Operation code
b	Frame Frequency Set	0	0	0	1	*	*	0/1	0/1	OSC ON/OFF D0=1:ON, D0=0:OFF Frame Frequency select D1=1:fosc/(256*3), D1=0: fosc/(512*3)
c	Sweep Function Select	0	0	1	0	*	0/1	0/1	0/1	Sweep Function LED1:D0=1: Enable, D0=0:Disable LED2:D1=1: Enable, D1=0:Disable LED3:D2=1: Enable, D2=0:Disable
d	LED1 Sweep Direction / Stepping Time	0	0	1	1	Direction		Time		Set up sweep direction and stepping time
	LED2 Sweep Direction / Stepping Time	0	1	0	0	Direction		Time		
	LED3 Sweep Direction / Stepping Time	0	1	0	1	Direction		Time		
e	LED1 PWM Data Set	0	1	1	0	PWM Data / Start Point				4-bit PWM data is set. /Set Start Point when Sweep Function enabled
	LED2 PWM Data Set	0	1	1	1	PWM Data / Start Point				
	LED3 PWM Data Set	1	0	0	0	PWM Data / Start Point				
f	LED1 Counter Number Set	1	0	0	1	Variable Value				Set Counter Number when Sweep Function enabled
	LED2 Counter Number Set	1	0	1	0	Variable Value				
	LED3 Counter Number Set	1	0	1	1	Variable Value				
g	Sweep Execute	1	1	0	0	*	0/1	0/1	0/1	Execute the Sweep Function LED1:D0=1: Execute, D0=0:Stop LED2:D1=1: Execute, D1=0:Stop LED3:D2=1: Execute, D2=0:Stop
h	Reset	1	1	0	1	*	*	*	*	Initialize the internal circuits
i	Test	1	1	1	0	Test Data				Inhibited command
		1	1	1	1	Test Data				

\* : Don't Care

## (2-1) Explanation of Instruction Code

### (a) NOP

This instruction is Non Operating code.

D <sub>7</sub>	D <sub>6</sub>	D <sub>5</sub>	D <sub>4</sub>	D <sub>3</sub>	D <sub>2</sub>	D <sub>1</sub>	D <sub>0</sub>
0	0	0	0	*	*	*	*

### (b) Frame Frequency Set

This instruction set the PWM frame frequency and oscillator ON/OFF.

D <sub>7</sub>	D <sub>6</sub>	D <sub>5</sub>	D <sub>4</sub>	D <sub>3</sub>	D <sub>2</sub>	D <sub>1</sub>	D <sub>0</sub>
0	0	0	1	*	*	f <sub>PWM</sub>	OSC

#### OSC ON/OFF

- D<sub>0</sub> 0 : Oscillator OFF(Default)
- 1 : Oscillator ON

#### PWM Frequency set

- D<sub>1</sub> 0 : fosc / (256\*3) frequency(Default)
- 1 : fosc / (512\*3) frequency

### (c) Sweep Function Select

This instruction is used to select Sweep Function for each LED.

D <sub>7</sub>	D <sub>6</sub>	D <sub>5</sub>	D <sub>4</sub>	D <sub>3</sub>	D <sub>2</sub>	D <sub>1</sub>	D <sub>0</sub>
0	0	1	0	*	LED3	LED2	LED1

- D<sub>0</sub> 0 : LED1 Sweep Function Disable
- 1 : LED1 Sweep Function Enable
- D<sub>1</sub> 0 : LED2 Sweep Function Disable
- 1 : LED2 Sweep Function Enable
- D<sub>2</sub> 0 : LED3 Sweep Function Disable
- 1 : LED3 Sweep Function Enable

### (d) LED1 to 3 Sweep Direction/ Stepping Time

This instruction set the Sweep Direction/ Stepping Time to each LED when Sweep Function active.

#### LED1 Sweep Direction/ Stepping Time Set

D <sub>7</sub>	D <sub>6</sub>	D <sub>5</sub>	D <sub>4</sub>	D <sub>3</sub>	D <sub>2</sub>	D <sub>1</sub>	D <sub>0</sub>
0	0	1	1	Direction		Time	

#### LED2 Sweep Direction/ Stepping Time Set

D <sub>7</sub>	D <sub>6</sub>	D <sub>5</sub>	D <sub>4</sub>	D <sub>3</sub>	D <sub>2</sub>	D <sub>1</sub>	D <sub>0</sub>
0	1	0	0	Direction		Time	

#### LED3 Sweep Direction/ Stepping Time Set

D <sub>7</sub>	D <sub>6</sub>	D <sub>5</sub>	D <sub>4</sub>	D <sub>3</sub>	D <sub>2</sub>	D <sub>1</sub>	D <sub>0</sub>
0	1	0	1	Direction		Time	

D <sub>3</sub>	D <sub>2</sub>	Direction
0	0	HALT
0	1	UP
1	0	DOWN
1	1	Prohibit

D <sub>1</sub>	D <sub>0</sub>	Time
0	0	8-frame (15.36ms)
0	1	16-frame (30.72ms)
1	0	24-frame (46.08ms)
1	1	32-frame (61.44ms)

fosc=400kHz, Frame Frequency Set D<sub>1</sub>=0



(e) LED1 to 3 PWM Data Set

This instruction set the PWM duty cycle. When the data is set up, the output will change from the next frame.  
If using Sweep function, initialization will be executed.

LED1 PWM Data Set

D <sub>7</sub>	D <sub>6</sub>	D <sub>5</sub>	D <sub>4</sub>	D <sub>3</sub>	D <sub>2</sub>	D <sub>1</sub>	D <sub>0</sub>
0	1	1	0	PWM Data / Start Point			

LED2 PWM Data Set

D <sub>7</sub>	D <sub>6</sub>	D <sub>5</sub>	D <sub>4</sub>	D <sub>3</sub>	D <sub>2</sub>	D <sub>1</sub>	D <sub>0</sub>
0	1	1	1	PWM Data / Start Point			

LED3 PWM Data Set

D <sub>7</sub>	D <sub>6</sub>	D <sub>5</sub>	D <sub>4</sub>	D <sub>3</sub>	D <sub>2</sub>	D <sub>1</sub>	D <sub>0</sub>
1	0	0	0	PWM Data / Start Point			

D <sub>3</sub>	D <sub>2</sub>	D <sub>1</sub>	D <sub>0</sub>	PWM DUTY
0	0	0	0	0/128
0	0	0	1	1/128
0	0	1	0	2/128
0	0	1	1	3/128
0	1	0	0	5/128
0	1	0	1	8/128
0	1	1	0	13/128
0	1	1	1	19/128
1	0	0	0	27/128
1	0	0	1	36/128
1	0	1	0	46/128
1	0	1	1	59/128
1	1	0	0	73/128
1	1	0	1	90/128
1	1	1	0	108/128
1	1	1	1	128/128

(f) LED1 to 3 Counter Number

This instruction set the counter number when using the Sweep Function.

LED1 PWM Data Set

D <sub>7</sub>	D <sub>6</sub>	D <sub>5</sub>	D <sub>4</sub>	D <sub>3</sub>	D <sub>2</sub>	D <sub>1</sub>	D <sub>0</sub>
1	0	0	1	Counter Number			

LED2 PWM Data Set

D <sub>7</sub>	D <sub>6</sub>	D <sub>5</sub>	D <sub>4</sub>	D <sub>3</sub>	D <sub>2</sub>	D <sub>1</sub>	D <sub>0</sub>
1	0	1	0	Counter Number			

LED3 PWM Data Set

D <sub>7</sub>	D <sub>6</sub>	D <sub>5</sub>	D <sub>4</sub>	D <sub>3</sub>	D <sub>2</sub>	D <sub>1</sub>	D <sub>0</sub>
1	0	1	1	Counter Number			

D <sub>3</sub>	D <sub>2</sub>	D <sub>1</sub>	D <sub>0</sub>	Counter Number
0	0	0	0	0
0	0	0	1	1
0	0	1	0	2
0	0	1	1	3
0	1	0	0	4
0	1	0	1	5
0	1	1	0	6
0	1	1	1	7
1	0	0	0	8
1	0	0	1	9
1	0	1	0	10
1	0	1	1	11
1	1	0	0	12
1	1	0	1	13
1	1	1	0	14
1	1	1	1	15

If the counter number plus the PWM value(=PWM3-0) of the start point is larger than 15, after counting up to the maximum/minimum PWM value, PWM value will return to the minimum or maximum value, and count up again until the counting is over.

Ex.) Start point PWM value      8 (27/128 duty)  
 Counter Number                12  
 Sweep Direction                UP

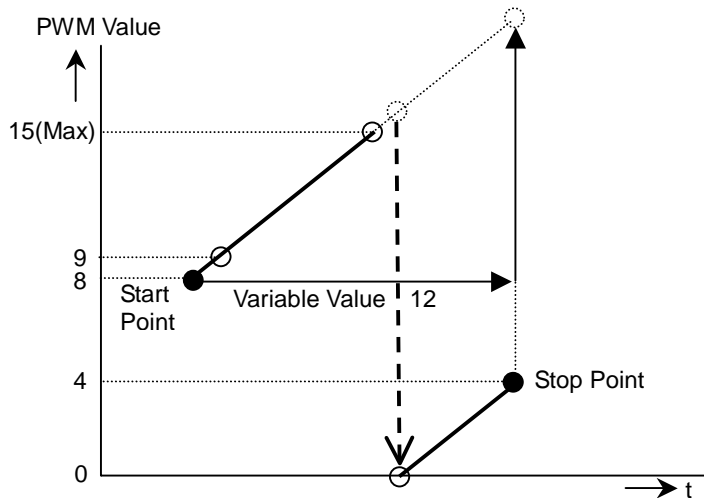

8(Start) → 9 → (Count up) → 15 (Max) → 0 (Min) → 4 (Stop)

(g) Sweep Execute

At the end of the program, as a request signal to CPU, the DATA pin becomes low, PWM value will be maintained as in the last count.

D <sub>7</sub>	D <sub>6</sub>	D <sub>5</sub>	D <sub>4</sub>	D <sub>3</sub>	D <sub>2</sub>	D <sub>1</sub>	D <sub>0</sub>
1	1	0	0	*	LED3	LED2	LED1

(\*:Don't Care)

LED1:D<sub>0</sub>     0 : Stop  
                   1 : Execute  
 LED2:D<sub>1</sub>     0 : Stop  
                   1 : Execute  
 LED3:D<sub>2</sub>     0 : Stop  
                   1 : Execute

(h) Reset

Different from hardware reset, using reset instruction can initialize the device too. When power ON, hardware reset should be executed

D <sub>7</sub>	D <sub>6</sub>	D <sub>5</sub>	D <sub>4</sub>	D <sub>3</sub>	D <sub>2</sub>	D <sub>1</sub>	D <sub>0</sub>
1	1	0	1	1	1	1	1

Reset status using the Reset instruction

1, f<sub>PWM</sub>                    0: fosc/(256\*3)  
 2, OSC                      0: Oscillation OFF  
 3, Sweep Function        Disable  
 4, Sweep Direction       0,0: HALT  
 5, Stepping Time         0,0: 8-frame  
 6, PWM data               0,0,0,0: 0/128  
 7, Counter Number       0,0,0,0  
 8, Sweep Execute        Stop

(i) Testing

This instruction is used only for device testing by the manufacturer.

If use this instruction by mistake, reset data again for an ordinary operation, To use reset instruction or input "L" into RSTb pin can make the testing mode ineffective

D <sub>7</sub>	D <sub>6</sub>	D <sub>5</sub>	D <sub>4</sub>	D <sub>3</sub>	D <sub>2</sub>	D <sub>1</sub>	D <sub>0</sub>
1	1	1	0	Test Data			

D <sub>7</sub>	D <sub>6</sub>	D <sub>5</sub>	D <sub>4</sub>	D <sub>3</sub>	D <sub>2</sub>	D <sub>1</sub>	D <sub>0</sub>
1	1	1	1	Test Data			

D <sub>3</sub>	D <sub>2</sub>	D <sub>1</sub>	D <sub>0</sub>	Test Data
0	0	0	0	Normal mode

### (3) Using Sweep Function

PWM program is enabled by setting D2-D0 of Sweep Function Select instruction to 1. The Sweep Function start to work by setting D2-D0 of Sweep Execute instruction to 1. When program is executed, the value of D2-D0 will become 0

After the execution of the program, DATA pin output “L” as a request signal at the last frame of PWM signal. CPU will detect from which LED port this request signal is sent out, and start to set next PWM program for this LED.

And the request signal can be outputted until the next Sweep Execution instruction is set up or the sweep function is halted.

Setting 0 to D2-D0 of the Sweep Function Select, the sweep function will be halted, and request signal is canceled.

During the program execution, sweep direction, stepping time, PWM data, and counter number can not be changed.

### Example) LED output pin PWM program for LED1

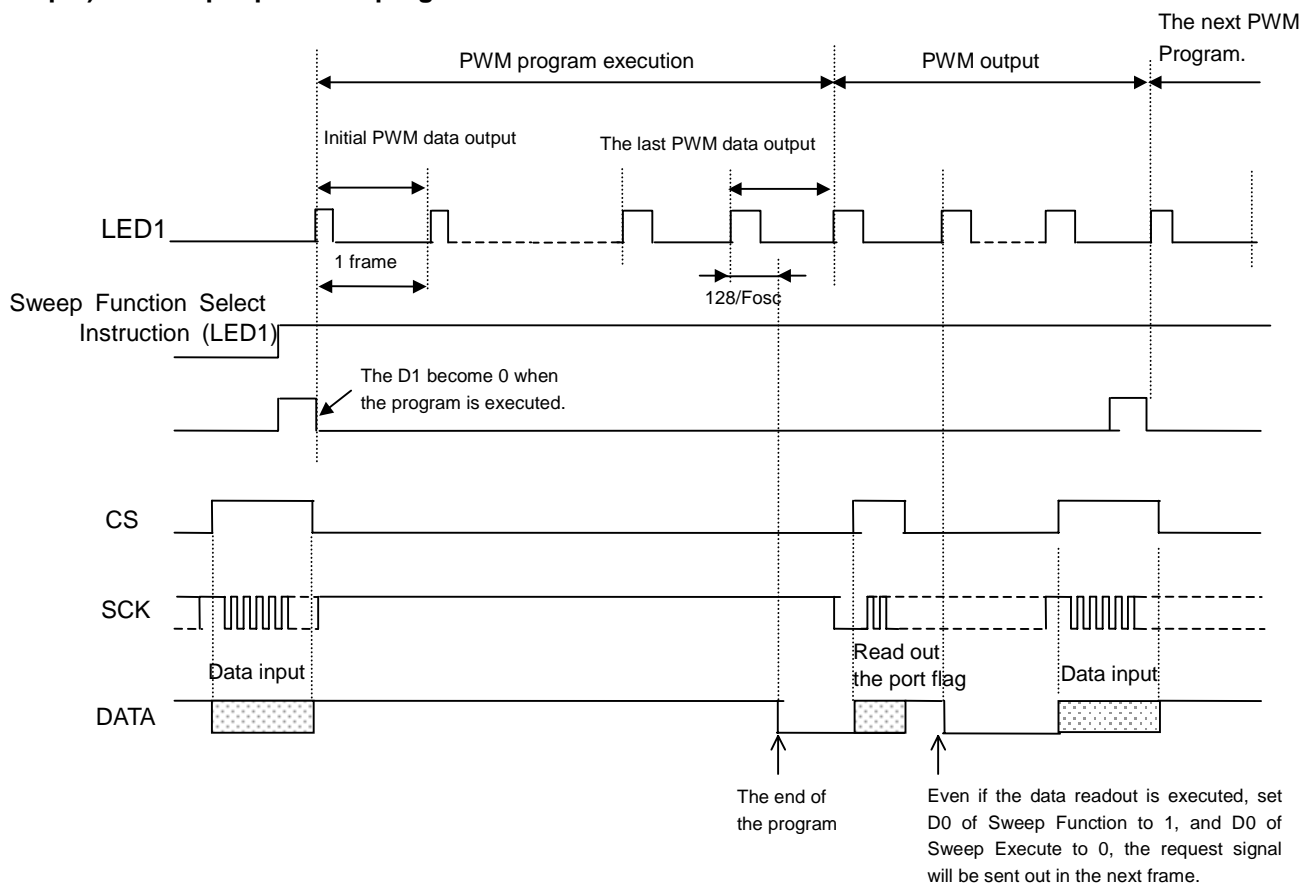

(4) Data Input Timing

Data format is shown below. When CS="L", I/F is in output state.  
 If the CS = "H" and CLK="H", I/F is in input state

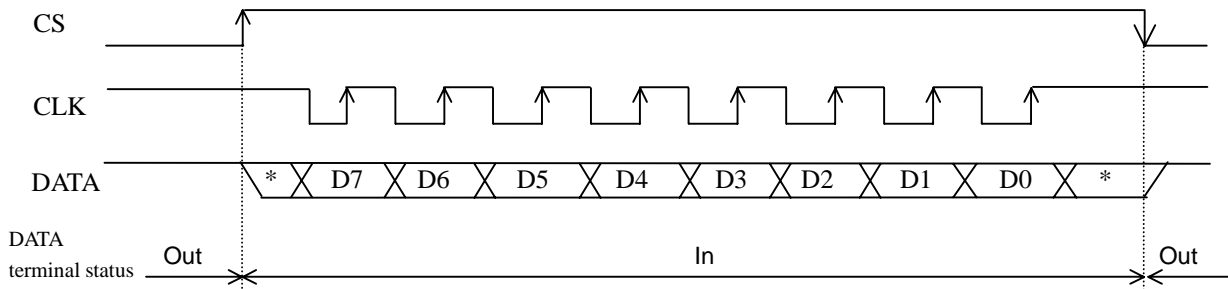

Note1) Data is read into the internal shift register at the rising edge of CLK.

Note2) The contents of the shift register are read into the internal instruction decoder circuit at the falling edge of CS.

note3) An instruction or PWM data shall be 8 bits. In case of entering over than 8 bits data, valid data is last 8 bits data.  
 The rest data is outputted from DATAOUT pin.

(4-1) Cascade Connect

DATAOUT pin can be cascaded. As shown in the flowing application circuit, several NJU6061s are connected and the data from CPU are latched up at the falling edge CS signal.

DATAOUT pin only output signal. The request signal from the second NJU6061 can not be read out.

Example) Connect three NJU6061s

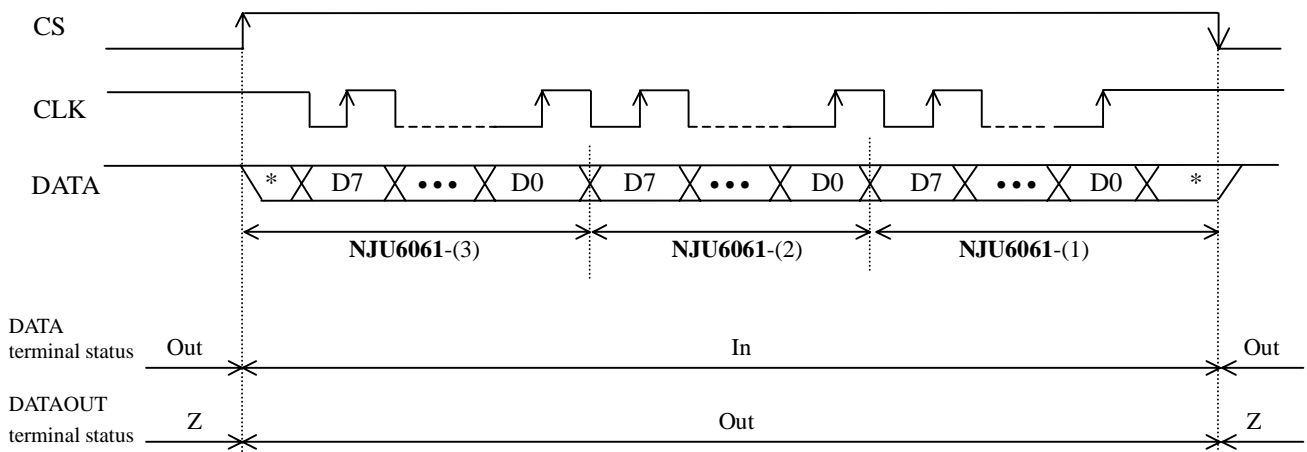
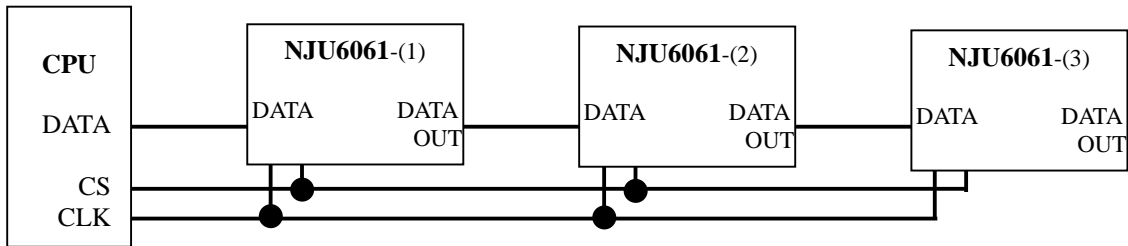

Z : Hi-Impedance

Note 1) In cascade connection, be sure to input a 8 x NJU6061 quantity bits data length, if less than this, the previous data will be input

## (5) Data Output Timing

The data output format shows bellow. At the rising edge of CS, if CLK="L", data is outputted.

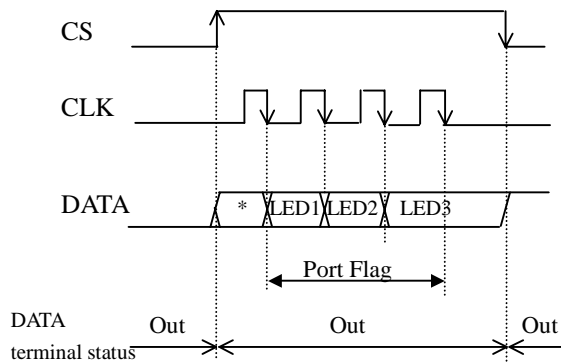

If more than 5 clocks is input, LED3 port flag will be hold.

After the port flag is read out, the request signal becomes "H". When D2-D0 of Sweep Function instruction are "1", and D2-D0 of Sweep Execute are "0", the request signal synchronize with frame signal and become "L".

When request signal ="H", all outputs are "H". If the continuous readout occurred within the frame, from the second readout, "H" are output.

### (5-1) Port Flag (LED1~LED3)

When Sweep function is over, these flags are set to "1".

## (6) Reset Circuit

The device is initialized by inputting a more than 400ns long signal into the RES terminal. Instruction can be input after 100 ns away from the rising edge of the reset signal,

Reset status using the RES terminal

1, $f_{PWM}$	0: $f_{osc}/(256*3)$
2, OSC	0: Oscillation OFF
3, Sweep Function	Disable
4, Sweep Direction	0,0: HALT
5, Stepping Time	0,0: 8-frame
6, PWM data	0,0,0,0: 0/128
7, Variable Value	0,0,0,0
8, Sweep Execute	Stop

## ■ ABSOLUTE MAXIMUM RATINGS

Ta=25°C

PARAMETERS	SYMBOL	CONDITIONS	RATINGS	UNIT
VDD Power Supply	V <sub>DD</sub>	VDD terminal	-0.3 to +7.0	V
Driver Off Break Down Voltage	V <sub>offmax</sub>	LED1, LED2, LED3 terminals	7.0	V
Driver On Break Down Voltage	V <sub>onmax</sub>	LED1, LED2, LED3 terminals	5.5	V
Input Voltage	V <sub>IN1</sub>	CSb, DATA, CLK, RSTb, OSC, EN Terminals	-0.3 to V <sub>DD</sub> +0.3	V
Power Dissipation	Pd <sub>max</sub>	Ta=25°C FFP12 SSOP14	TBD 250	mW
Operating Temperature	T <sub>opr</sub>		-40 to +85	°C
Storage Temperature	T <sub>stg</sub>		-55 to +125	°C

Note1) V<sub>SS</sub> = 0V to all conditions

Note2) If the LSI was used out of the absolute maximum ratings, LSI is damaged completely and the reliability become poor. The LSI is used on the electrical characteristics is recommended strongly for normal operation.

## ■ DC ELECTRICAL CHARACTERISTICS

V<sub>DD</sub>=1.7 to 5.5V, Ta=-40 to 85°C

PARAMETERS	SYMBOL	CONDITIONS	MIN.	TYP.	MAX.	Unit
V <sub>DD</sub> Power Supply	V <sub>DD</sub>		1.7		5.5	V
Input "H" Level Voltage	V <sub>IH</sub>	RSTb, CSb, CLK, DATA, EN	0.8V <sub>DD</sub>		V <sub>DD</sub>	V
Input "L" Level Voltage	V <sub>IL</sub>	RSTb, CSb, CLK, DATA, EN	0		0.2V <sub>DD</sub>	V
Input "H" Level Current	I <sub>IH</sub>	RSTb, CSb, CLK, DATA, EN V <sub>IN</sub> =V <sub>DD</sub>			5.0	μA
Input "L" Level Current	I <sub>IL</sub>	RSTb, CSb, CLK, DATA, EN V <sub>IN</sub> =0V	-5.0			μA
Output Off Leak Current	I <sub>OFFH</sub>	LED1, LED2, LED3: V <sub>O</sub> =5.5V, EN=0V			6.0	μA
3-state Leak Current	I <sub>TSL</sub>	DATA, DATAOUT	-4.0		2.0	μA
Output "H" Level Voltage(1)	V <sub>OH(1)</sub>	DATA, DATAOUT, I <sub>O</sub> =-0.1mA	0.8V <sub>DD</sub>			V
Output "L" Level Voltage(1)	V <sub>OL(1)</sub>	DATA, DATAOUT I <sub>O</sub> =0.1mA			0.2V <sub>DD</sub>	V
Output "L" Level Voltage(2)	V <sub>OL(2)</sub>	LED1, LED2, LED3, I <sub>O</sub> =10mA, V <sub>DD</sub> =1.7V			0.5	V
Output "L" Level Voltage(3)	V <sub>OL(3)</sub>	LED1, LED2, LED3, I <sub>O</sub> =30mA, V <sub>DD</sub> =3.0V			0.5	V
Pull-up Resistance Current	-I <sub>p</sub>	DATA V <sub>DD</sub> =3V	10	25	50	μA
Oscillation Frequency	f <sub>OSC</sub>	V <sub>DD</sub> =3V, R <sub>OSC</sub> =82kΩ, T <sub>a</sub> =25°C	280	400	520	kHz
Operating Current	I <sub>DD</sub>	V <sub>DD</sub> =3V, PWM DUTY: 27/128, Output terminal open, R <sub>OSC</sub> =82kΩ, T <sub>a</sub> =25°C		100	200	μA

Note1): Input Terminal Structure

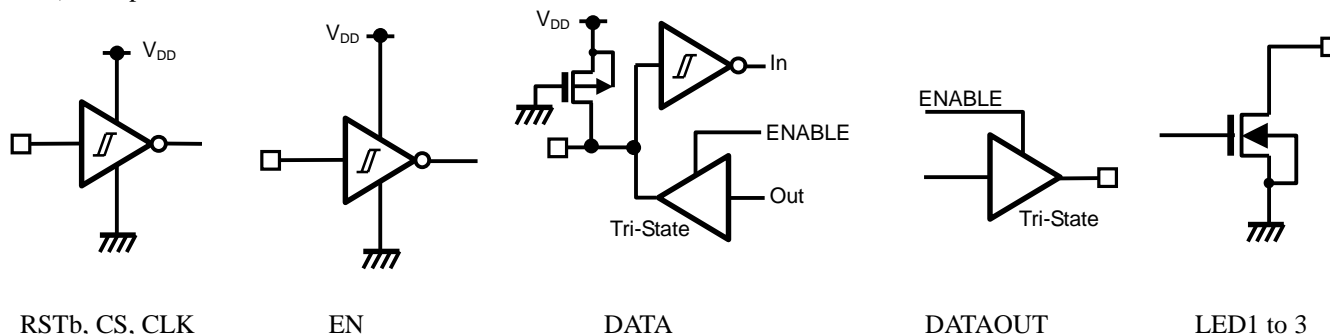

## ■ AC ELECTRICAL CHARACTERISTICS

VDD=2.4 to 5.5V, Ta=-40 to 85°C

PARAMETERS	SYMBOL	Terminal	MIN.	TYP.	MAX.	UNIT
“L” Level CLK Clock Width	t <sub>WCLL</sub>	CLK	40			ns
“H” Level CLK Clock Width	t <sub>WCLH</sub>	CLK	40			ns
Data Set-Up Time	t <sub>DS</sub>	CLK, DATA	40			ns
Data Hold Time	t <sub>DH</sub>	CLK, DATA	40			ns
CS Wait Time	t <sub>cp</sub>	CS, CLK	40			ns
CSb Set-Up Time	t <sub>CS</sub>	CS, CLK	40			ns
CSb Hold Time	t <sub>CH</sub>	CS, CLK	40			ns
CSb “L” Level Width	t <sub>WCL</sub>	CS	100			ns
Output Delay Time	t <sub>DC</sub>	DATA, DATAOUT CL=10pF			80	ns
DATA Rise Time	t <sub>DR</sub>	DATA CL=10pF			100	ns
DATAOUT Enable Time	t <sub>DOZL</sub> t <sub>DOZH</sub>	DATAOUT CL=10pF, RL=10kΩ			60	ns
DATAOUT Disable Time	t <sub>DOLZ</sub> t <sub>DOHZ</sub>	DATAOUT CL=10pF, RL=10kΩ			200	ns
LED Enable Time	t <sub>LZL</sub>	LED1, LED2, LED3, EN CL=10pF, RL=10kΩ			40	ns
LED Disable Time	t <sub>LLZ</sub>	LED1, LED2, LED3, EN CL=10pF, RL=10kΩ			200	ns
RESET “L” Level Width	t <sub>RW</sub>	RSTb	400			ns
RESET Time	t <sub>R</sub>	RSTb	100			ns
Rising Time	t <sub>r</sub>	CS, CLK, DATA, RSTb			15	ns
Falling Time	t <sub>f</sub>	CS, CLK, DATA, RSTb			15	ns

VDD=1.7 to 2.4V, Ta=-40 to 85°C

PARAMETERS	SYMBOL	Terminal	MIN.	TYP.	MAX.	UNIT
“L” Level CLK Clock Width	t <sub>WCLL</sub>	CLK	80			ns
“H” Level CLK Clock Width	t <sub>WCLH</sub>	CLK	80			ns
Data Set-Up Time	t <sub>DS</sub>	CLK, DATA	80			ns
Data Hold Time	t <sub>DH</sub>	CLK, DATA	80			ns
CS Wait Time	t <sub>cp</sub>	CS, CLK	80			ns
CSb Set-Up Time	t <sub>CS</sub>	CS, CLK	80			ns
CSb Hold Time	t <sub>CH</sub>	CS, CLK	80			ns
CSb “L” Level Width	t <sub>WCL</sub>	CS	200			ns
Output Delay Time	t <sub>DC</sub>	DATA, DATAOUT CL=10pF			412	ns
DATA Rise Time	t <sub>DR</sub>	DATA CL=10pF			200	ns
DATAOUT Enable Time	t <sub>DOZL</sub> t <sub>DOZH</sub>	DATAOUT CL=10pF, RL=10kΩ			100	ns
DATAOUT Disable Time	t <sub>DOLZ</sub> t <sub>DOHZ</sub>	DATAOUT CL=10pF, RL=10kΩ			400	ns
LED Enable Time	t <sub>LZL</sub>	LED1, LED2, LED3, EN CL=10pF, RL=10kΩ			80	ns
LED Disable Time	t <sub>LLZ</sub>	LED1, LED2, LED3, EN CL=10pF, RL=10kΩ			400	ns
RESET “L” Level Width	t <sub>RW</sub>	RSTb	800			ns
RESET Time	t <sub>R</sub>	RSTb	200			ns
Rising Time	t <sub>r</sub>	CS, CLK, DATA, RSTb			15	ns
Falling Time	t <sub>f</sub>	CS, CLK, DATA, RSTb			15	ns



## (1) Data Input Timing

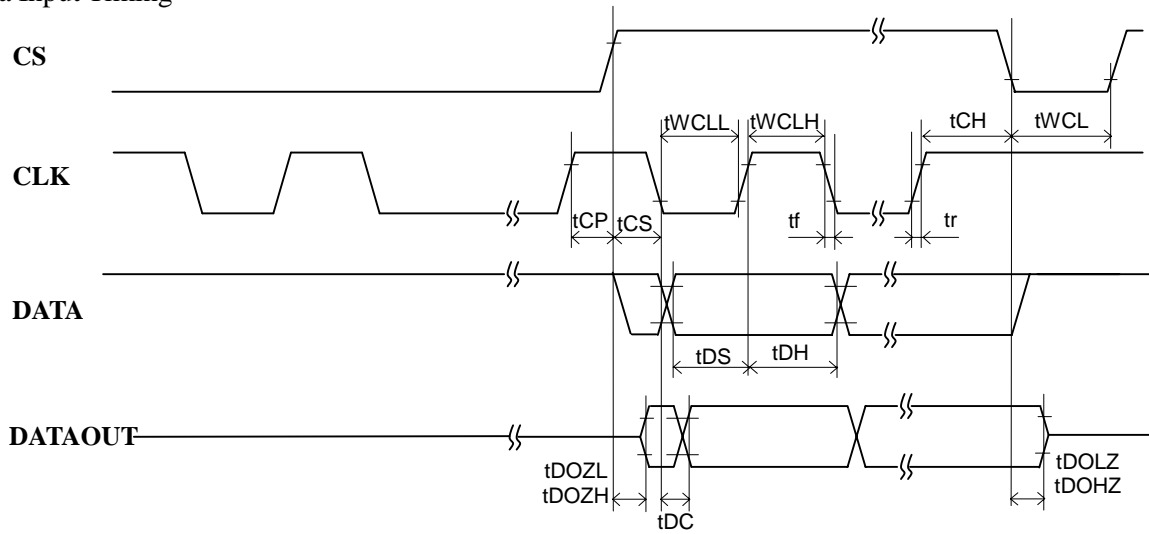

## (2) Data Output Timing

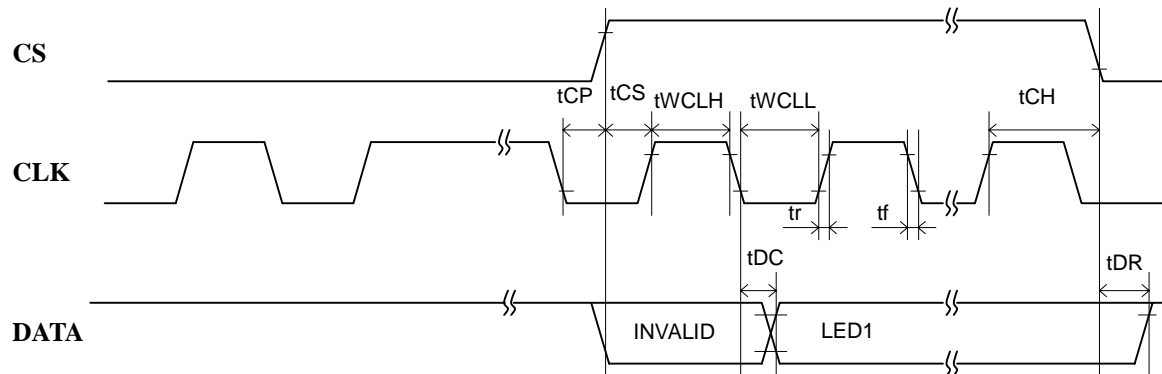

## (3) Reset Timing

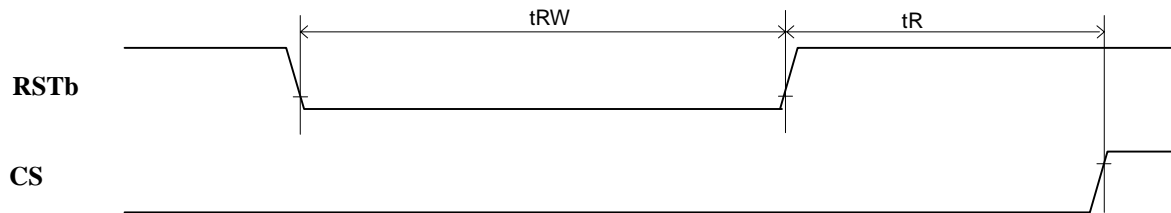

## (4) LED Enable Timing

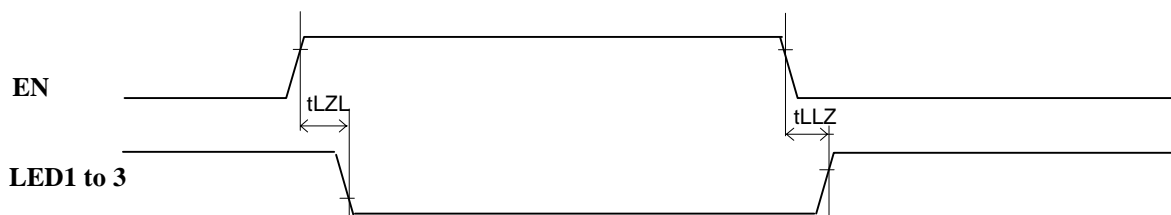

Note) All timing based on  $V_{DD}$ ,  $V_{SS}$  voltage level.

## APPLICATION CIRCUIT

Example 1

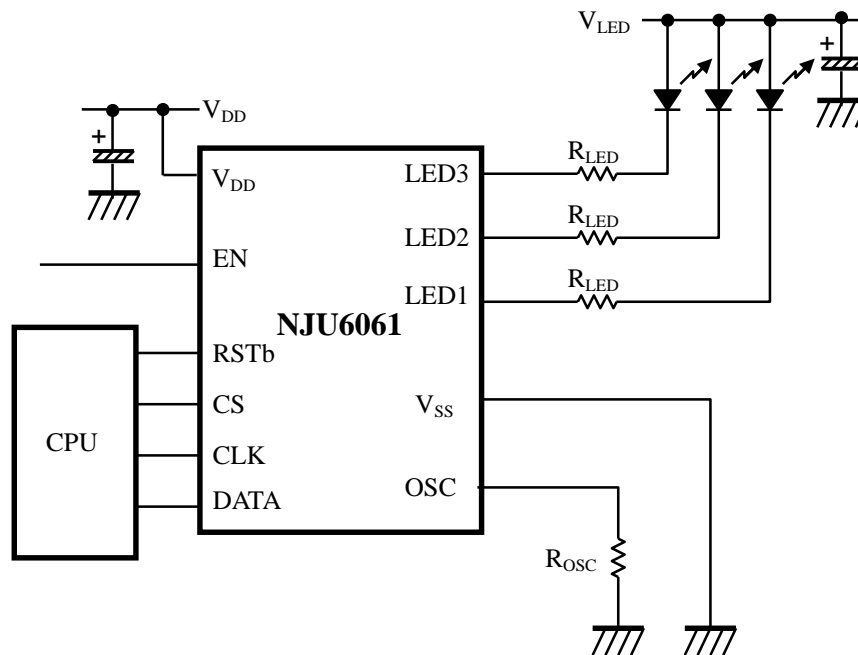

Resistor Selection

$$R_{LED} = \frac{V_{LED} - V_F - V_{OL}}{I_{LED}}$$

$R_{LED}$ : LED Current Control Resistor  
 $V_{LED}$ : LED Voltage  
 $V_F$ : LED Forward Voltage (@ $I_{LED}$ )  
 $V_{OL}$ : Output "L" Level Voltage (@ $I_{LED}$ )  
 $I_{LED}$ : LED Forward Current

Example)  $I_{LED} = 30\text{mA}$ ,  $V_{LED} = 5.0\text{V}$ ,  $V_F = 2.0\text{V} (@I_{LED} = 30\text{mA})$ ,  $V_{OL} = 0.5\text{V}$

$$R_{LED} = \frac{5.0\text{V} - 2.0\text{V} - 0.5\text{V}}{30\text{mA}} = 83.3\Omega$$

Note)  $V_F$  and  $V_{OL}$  are depended on the situation. And decide the optimum values by the actual test when  $R_{LED}$  is selected.

Example 2 (Cascade connect)

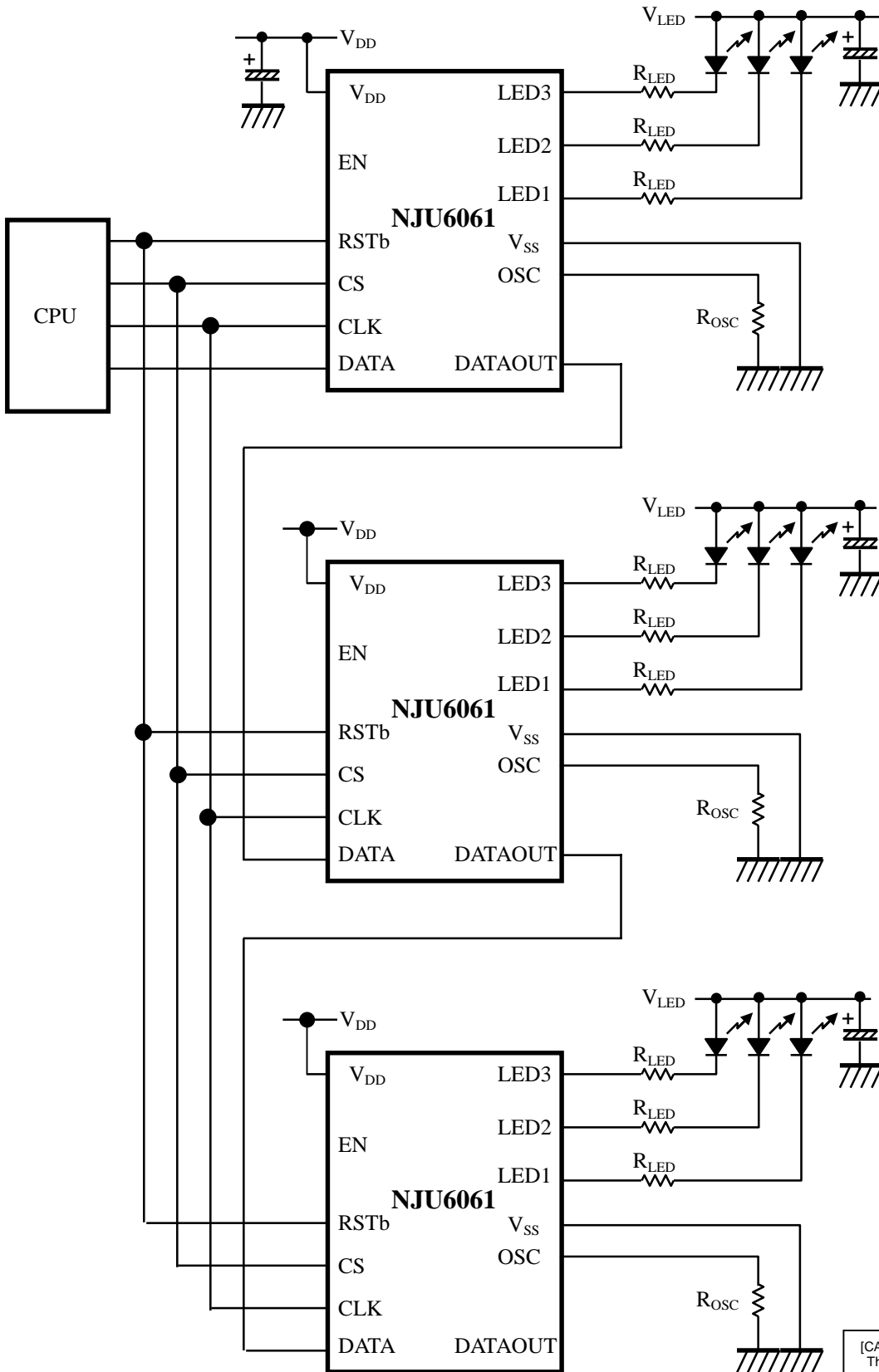

[CAUTION]  
 The specifications on this databook are only given for information, without any guarantee as regards either mistakes or omissions. The application circuits in this databook are described only to show representative usages of the product and not intended for the guarantee or permission of any right including the industrial rights.