

MCP (Multi-Chip Package) FLASH MEMORY & SRAM CMOS

8M (× 8/× 16) FLASH MEMORY & 2M (× 8) STATIC RAM

MB84VA2002-10/MB84VA2003-10

■ FEATURES

- Power supply voltage of 2.7 to 3.6 V
- High performance
100 ns maximum access time
- Operating Temperature
-20 to +85°C

— FLASH MEMORY

- Minimum 100,000 write/erase cycles
- Sector erase architecture
One 16 K byte, two 8 K bytes, one 32 K byte, and fifteen 64 K bytes.
Any combination of sectors can be concurrently erased. Also supports full chip erase.
- Boot Code Sector Architecture
MB84VA2002: Top sector
MB84VA2003: Bottom sector
- Embedded Erase™ Algorithms
Automatically pre-programs and erases the chip or any sector
- Embedded Program™ Algorithms
Automatically writes and verifies data at specified address
- Data Polling and Toggle Bit feature for detection of program or erase cycle completion
- Ready-Busy output (RY/BY)
Hardware method for detection of program or erase cycle completion
- Automatic sleep mode
When addresses remain stable, automatically switch themselves to low power mode.
- Low V_{cc} write inhibit ≤ 2.5 V
- Erase Suspend/Resume
Suspends the erase operation to allow a read in another sector within the same device
- Please refer to "MBM29LV800TA/BA" data sheet in detailed function

— SRAM

- Power dissipation
Operating : 35 mA max.
Standby : 50 μA max.
- Power down features using $\overline{CE1}$ s and CE2s
- Data retention supply voltage: 2.0 V to 3.6 V

MB84VA2002-10/MB84VA2003-10

■ BLOCK DIAGRAM

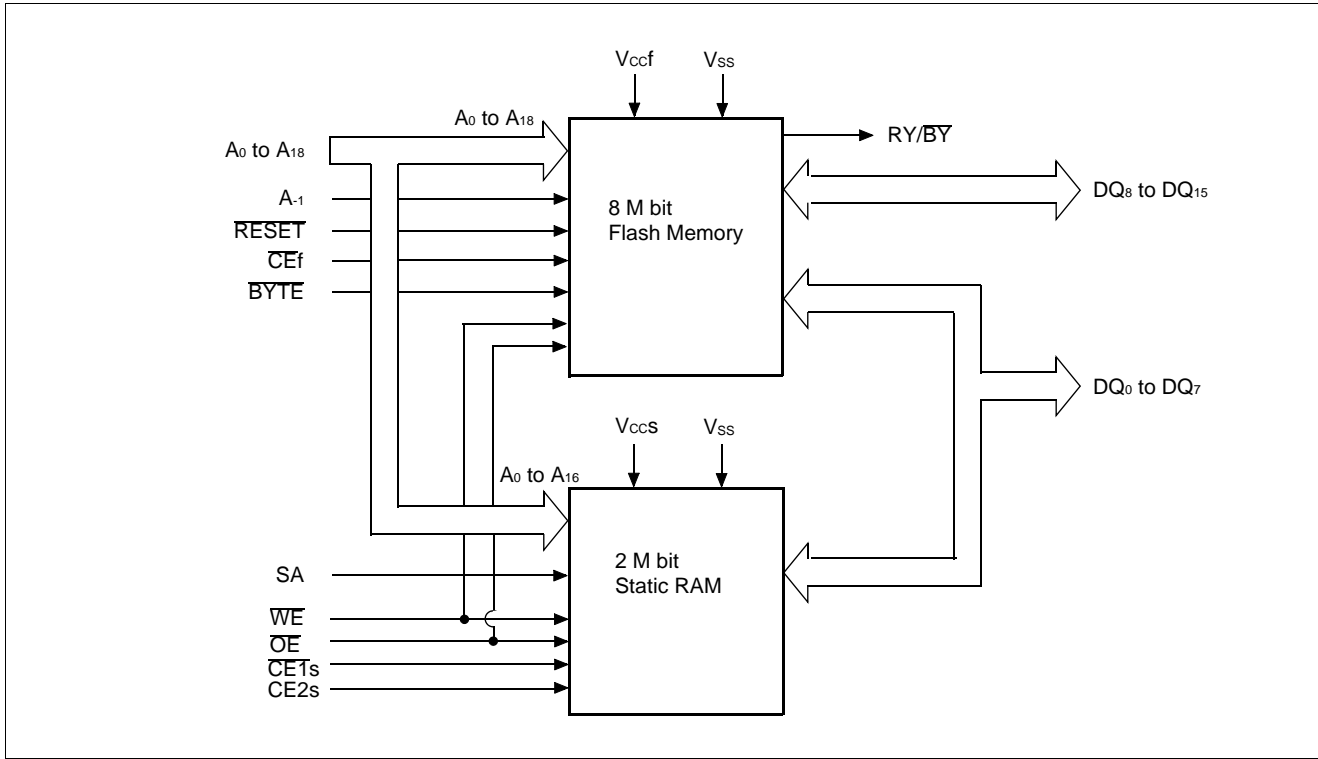

■ EXAMPLE OF CONNECTION WITH CHIPSET

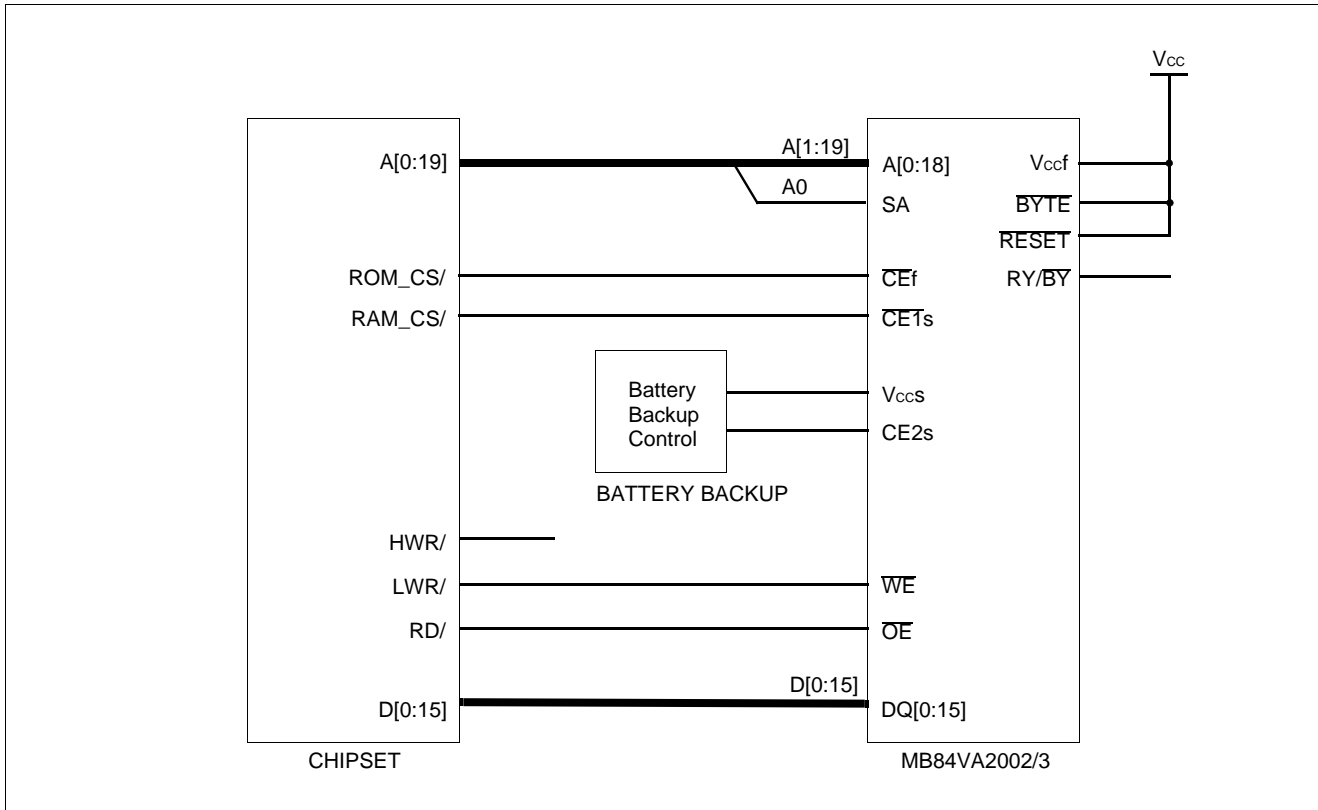

MB84VA2002-10/MB84VA2003-10

■ PIN ASSIGNMENTS

(Top View)

	A	B	C	D	E	F	G	H
6	$\overline{CE}1s$	V _{SS}	DQ ₁	A ₁	A ₂	A ₄	CE2s	A ₉
5	A ₁₀	DQ ₅	DQ ₂	A ₀	A ₃	A ₇	RY/ \overline{BY}	A ₁₄
4	\overline{OE}	DQ ₇	DQ ₄	DQ ₀	A ₆	A ₁₈	RESET	A ₁₅
3	A ₁₁	A ₈	A ₅	DQ ₈	DQ ₃	DQ ₁₂	A ₁₂	BYTE
2	A ₁₃	A ₁₇	SA*	$\overline{CE}f$	DQ ₁₀	V _{ccf}	DQ ₆	DQ ₁₅ /A ₋₁
1	\overline{WE}	V _{CCS}	A ₁₆	V _{SS}	DQ ₉	DQ ₁₁	DQ ₁₃	DQ ₁₄

*: A₁₇ for SRAM

Table 1 Pin Configuration

Pin	Function	Input/ Output
A ₀ to A ₁₆	Address Inputs (Common)	I
A ₋₁ , A ₁₇ to A ₁₈	Address Input (Flash)	I
SA	Address Input (SRAM)	I
DQ ₀ to DQ ₇	Data Inputs/Outputs (Common)	I/O
DQ ₈ to DQ ₁₅	Data Inputs/Outputs (Flash)	I/O
$\overline{CE}f$	Chip Enable (Flash)	I
$\overline{CE}1s$	Chip Enable (SRAM)	I
CE2s	Chip Enable (SRAM)	I
\overline{OE}	Output Enable (Common)	I
\overline{WE}	Write Enable (Common)	I
RY/ \overline{BY}	Ready/Busy Outputs (Flash)	O
BYTE	Selects 8-bit or 16-bit mode (Flash)	I
RESET	Hardware Reset Pin/Sector Protection Unlock (Flash)	I
N.C.	No Internal Connection	—
V _{SS}	Device Ground (Common)	Power
V _{ccf}	Device Power Supply (Flash)	Power
V _{CCS}	Device Power Supply (SRAM)	Power

MB84VA2002-10/MB84VA2003-10

■ PRODUCT LINE UP

		Flash Memory	SRAM
Ordering Part No.	$V_{CC} = 3.0\text{ V} \begin{matrix} +0.6\text{ V} \\ -0.3\text{ V} \end{matrix}$	MB84VA2002-10/MB84VA2003-10	
Max. Address Access Time (ns)		100	100
Max. \overline{CE} Access Time (ns)		100	100
Max. \overline{OE} Access Time (ns)		40	50

■ BUS OPERATIONS

Table 2 User Bus Operations (BYTE= V_{IL})

Operation (1), (3)	\overline{CEf}	$\overline{CE1s}$	$\overline{CE2s}$	\overline{OE}	\overline{WE}	DQ ₀ to DQ ₇	DQ ₈ to DQ ₁₅	RESET
Full Standby	H	H	X	X	X	HIGH-Z	HIGH-Z	H
		X	L					
Output Disable	X	X	X	H	H	HIGH-Z	HIGH-Z	H
Read from Flash (2)	L	H	X	L	H	D _{OUT}	HIGH-Z	H
		X	L					
Write to Flash	L	H	X	H	L	D _{IN}	HIGH-Z	H
		X	L					
Read from SRAM	H	L	H	L	H	D _{OUT}	HIGH-Z	H
Write to SRAM	H	L	H	X	L	D _{IN}	HIGH-Z	H
Flash Hardware Reset	X	H	X	X	X	HIGH-Z	HIGH-Z	L
		X	L					

Table 3 User Bus Operations (BYTE= V_{IH})

Operation (1), (3)	\overline{CEf}	$\overline{CE1s}$	$\overline{CE2s}$	\overline{OE}	\overline{WE}	DQ ₀ to DQ ₇	DQ ₈ to DQ ₁₅	RESET
Full Standby	H	H	X	X	X	HIGH-Z	HIGH-Z	H
		X	L					
Output Disable	X	X	X	H	H	HIGH-Z	HIGH-Z	H
Read from Flash (2)	L	H	X	L	H	D _{OUT}	D _{OUT}	H
		X	L					
Write to Flash	L	H	X	H	L	D _{IN}	D _{IN}	H
		X	L					
Read from SRAM	H	L	H	L	H	D _{OUT}	HIGH-Z	H
Write to SRAM	H	L	H	X	L	D _{IN}	HIGH-Z	H
Flash Hardware Reset	X	H	X	X	X	HIGH-Z	HIGH-Z	L
		X	L					

Legend: L = V_{IL} , H = V_{IH} , X = V_{IL} or V_{IH} . See DC Characteristics for voltage levels.

- Notes:**
1. Other operations except for indicated this column are inhibited.
 2. \overline{WE} can be V_{IL} if \overline{OE} is V_{IL} , \overline{OE} at V_{IH} initiates the write operations.
 4. Do not apply $\overline{CEf} = V_{IL}$, $\overline{CE1s} = V_{IL}$ and $\overline{CE2s} = V_{IH}$ at a time.

MB84VA2002-10/MB84VA2003-10

■ FLEXIBLE SECTOR-ERASE ARCHITECTURE on FLASH MEMORY

- One 16 K byte, two 8 K bytes, one 32 K byte, and fifteen 64 K bytes.
- Individual-sector, multiple-sector, or bulk-erase capability.

	(×8)	(×16)		(×8)	(×16)
16K byte	FFFFFH	7FFFFH	64K byte	FFFFFH	7FFFFH
8K byte	FC000H	7E000H	64K byte	F0000H	78000H
8K byte	FA000H	7D000H	64K byte	E0000H	70000H
32K byte	F8000H	7C000H	64K byte	D0000H	68000H
64K byte	F0000H	78000H	64K byte	C0000H	60000H
64K byte	E0000H	70000H	64K byte	B0000H	58000H
64K byte	D0000H	68000H	64K byte	A0000H	50000H
64K byte	C0000H	60000H	64K byte	90000H	48000H
64K byte	B0000H	58000H	64K byte	80000H	40000H
64K byte	A0000H	50000H	64K byte	70000H	38000H
64K byte	90000H	48000H	64K byte	60000H	30000H
64K byte	80000H	40000H	64K byte	50000H	28000H
64K byte	70000H	38000H	64K byte	40000H	20000H
64K byte	60000H	30000H	64K byte	30000H	18000H
64K byte	50000H	28000H	64K byte	20000H	10000H
64K byte	40000H	20000H	32K byte	10000H	08000H
64K byte	30000H	18000H	8K byte	08000H	04000H
64K byte	20000H	10000H	8K byte	06000H	03000H
64K byte	10000H	08000H	16K byte	04000H	02000H
64K byte	00000H	00000H		00000H	00000H

MB84VA2002 Sector Architecture

MB84VA2003 Sector Architecture

MB84VA2002-10/MB84VA2003-10

Table 4 Sector Address Tables (MB84VA2002)

Sector Address	A ₁₈	A ₁₇	A ₁₆	A ₁₅	A ₁₄	A ₁₃	A ₁₂	Address Range (×8)	Address Range (×16)
SA0	0	0	0	0	X	X	X	00000H to 0FFFFH	00000H to 07FFFFH
SA1	0	0	0	1	X	X	X	10000H to 1FFFFH	08000H to 0FFFFH
SA2	0	0	1	0	X	X	X	20000H to 2FFFFH	10000H to 17FFFFH
SA3	0	0	1	1	X	X	X	30000H to 3FFFFH	18000H to 1FFFFH
SA4	0	1	0	0	X	X	X	40000H to 4FFFFH	20000H to 27FFFFH
SA5	0	1	0	1	X	X	X	50000H to 5FFFFH	28000H to 2FFFFH
SA6	0	1	1	0	X	X	X	60000H to 6FFFFH	30000H to 37FFFFH
SA7	0	1	1	1	X	X	X	70000H to 7FFFFH	38000H to 3FFFFH
SA8	1	0	0	0	X	X	X	80000H to 8FFFFH	40000H to 47FFFFH
SA9	1	0	0	1	X	X	X	90000H to 9FFFFH	48000H to 4FFFFH
SA10	1	0	1	0	X	X	X	A0000H to AFFFFH	50000H to 57FFFFH
SA11	1	0	1	1	X	X	X	B0000H to BFFFFH	58000H to 5FFFFH
SA12	1	1	0	0	X	X	X	C0000H to CFFFFH	60000H to 67FFFFH
SA13	1	1	0	1	X	X	X	D0000H to DFFFFH	68000H to 6FFFFH
SA14	1	1	1	0	X	X	X	E0000H to EFFFFH	70000H to 77FFFFH
SA15	1	1	1	1	0	X	X	F0000H to F7FFFFH	78000H to 7BFFFFH
SA16	1	1	1	1	1	0	0	F8000H to F9FFFFH	7C000H to 7CFFFFH
SA17	1	1	1	1	1	0	1	FA000H to FBFFFFH	7D000H to 7DFFFFH
SA18	1	1	1	1	1	1	X	FC000H to FFFFFH	7E000H to 7FFFFH

MB84VA2002-10/MB84VA2003-10

Table 5 Sector Address Tables (MB84VA2003)

Sector Address	A ₁₈	A ₁₇	A ₁₆	A ₁₅	A ₁₄	A ₁₃	A ₁₂	Address Range (×8)	Address Range (×16)
SA0	0	0	0	0	0	0	X	00000H to 03FFFFH	00000H to 01FFFFH
SA1	0	0	0	0	0	1	0	04000H to 05FFFFH	02000H to 02FFFFH
SA2	0	0	0	0	0	1	1	06000H to 07FFFFH	03000H to 03FFFFH
SA3	0	0	0	0	1	X	X	08000H to 0FFFFH	04000H to 07FFFFH
SA4	0	0	0	1	X	X	X	10000H to 1FFFFH	08000H to 0FFFFH
SA5	0	0	1	0	X	X	X	20000H to 2FFFFH	10000H to 17FFFFH
SA6	0	0	1	1	X	X	X	30000H to 3FFFFH	18000H to 1FFFFH
SA7	0	1	0	0	X	X	X	40000H to 4FFFFH	20000H to 27FFFFH
SA8	0	1	0	1	X	X	X	50000H to 5FFFFH	28000H to 2FFFFH
SA9	0	1	1	0	X	X	X	60000H to 6FFFFH	30000H to 37FFFFH
SA10	0	1	1	1	X	X	X	70000H to 7FFFFH	38000H to 3FFFFH
SA11	1	0	0	0	X	X	X	80000H to 8FFFFH	40000H to 47FFFFH
SA12	1	0	0	1	X	X	X	90000H to 9FFFFH	48000H to 4FFFFH
SA13	1	0	1	0	X	X	X	A0000H to AFFFFH	50000H to 57FFFFH
SA14	1	0	1	1	X	X	X	B0000H to BFFFFH	58000H to 5FFFFH
SA15	1	1	0	0	X	X	X	C0000H to CFFFFH	60000H to 67FFFFH
SA16	1	1	0	1	X	X	X	D0000H to DFFFFH	68000H to 6FFFFH
SA17	1	1	1	0	X	X	X	E0000H to EFFFFH	70000H to 77FFFFH
SA18	1	1	1	1	X	X	X	F0000H to FFFFFH	78000H to 7FFFFH

MB84VA2002-10/MB84VA2003-10

Table 6.1 Flash Memory Autoselect Codes

Type		A ₆	A ₁	A ₀	A ₋₁ ^{*1}	Code (HEX)
Manufacturer's Code		V _{IL}	V _{IL}	V _{IL}	V _{IL}	04H
Device Code	MB84VA2002	V _{IL}	V _{IL}	V _{IH}	V _{IL}	DAH
					X	22DAH
	MB84VA2003	V _{IL}	V _{IL}	V _{IH}	V _{IL}	5BH
					X	225BH

*1: A₋₁ is for Byte mode.

Table 6.2 Expanded Autoselect Code Table

Type		Code	DQ ₁₅	DQ ₁₄	DQ ₁₃	DQ ₁₂	DQ ₁₁	DQ ₁₀	DQ ₉	DQ ₈	DQ ₇	DQ ₆	DQ ₅	DQ ₄	DQ ₃	DQ ₂	DQ ₁	DQ ₀
Manufacturer's Code		04H	A ₋₁ /0	0	0	0	0	0	0	0	0	0	0	0	0	1	0	0
Device Code	MB84VA2002 (B) (W)	DAH	A ₋₁	HI-Z	HI-Z	HI-Z	HI-Z	HI-Z	HI-Z	HI-Z	1	1	0	1	1	0	1	0
		22DAH	0	0	1	0	0	0	1	0	1	1	0	1	1	0	1	0
Device Code	MB84VA2003 (B) (W)	5BH	A ₋₁	HI-Z	HI-Z	HI-Z	HI-Z	HI-Z	HI-Z	HI-Z	0	1	0	1	1	0	1	1
		225BH	0	0	1	0	0	0	1	0	0	1	0	1	1	0	1	1

(B): Byte mode

(W): Word mode

MB84VA2002-10/MB84VA2003-10

Table 7 Flash Memory Command Definitions

Command Sequence		Bus Write Cycles Req'd	First Bus Write Cycle		Second Bus Write Cycle		Third Bus Write Cycle		Fourth Bus Read/Write Cycle		Fifth Bus Write Cycle		Sixth Bus Write Cycle	
			Addr.	Data	Addr.	Data	Addr.	Data	Addr.	Data	Addr.	Data	Addr.	Data
Read/Reset	word Byte	1	XXXH	F0H	—	—	—	—	—	—	—	—	—	—
Read/Reset	word Byte	3	555H AAAH	AAH	2AAH 555H	55H	555H AAAH	F0H	RA	RD	—	—	—	—
Autoselect	word Byte	3	555H AAAH	AAH	2AAH 555H	55H	555H AAAH	90H	—	—	—	—	—	—
Program	word Byte	4	555H AAAH	AAH	2AAH 555H	55H	555H AAAH	A0H	PA	PD	—	—	—	—
Chip Erase	word Byte	6	555H AAAH	AAH	2AAH 555H	55H	555H AAAH	80H	555H AAAH	AAH	2AAH 555H	55H	555H AAAH	10H
Sector Erase	word Byte	6	555H AAAH	AAH	2AAH 555H	55H	555H AAAH	80H	555H AAAH	AAH	2AAH 555H	55H	SA	30H
Sector Erase Suspend			Erase can be suspended during sector erase with Addr ("H" or "L"). Data (B0H)											
Sector Erase Resume			Erase can be resumed after suspend with Addr ("H" or "L"). Data (30H)											
Set to Fast Mode	word Byte	3	555H AAAH	AAH	2AAH 555H	55H	555H AAAH	20H	—	—	—	—	—	—
Fast Program (Note)	word Byte	2	XXXH XXXH	A0H	PA	PD	—	—	—	—	—	—	—	—
Reset from Fast Mode	word Byte	2	XXXH XXXH	90H	XXXH XXXH	F0H	—	—	—	—	—	—	—	—
Extended Sector Protect	word Byte	4	XXXH	60H	SPA	60H	SPA	40H	SPA	SD	—	—	—	—

Address bits A₁₁ to A₂₀ = X = "H" or "L" for all address commands except for Program Address (PA) and Sector Address (SA).

Bus operations are defined in Table 2.

Both Read/Reset commands are functionally equivalent, resetting the device to the read mode.

RA =Address of the memory location to be read.

PA =Address of the memory location to be programmed. Addresses are latched on the falling edge of the write pulse.

SA =Address of the sector to be erased. The combination of A₂₀, A₁₉, A₁₈, A₁₇, A₁₆, A₁₅, A₁₄, and A₁₃ will uniquely select any sector.

RD =Data read from location RA during read operation.

PD =Data to be programmed at location PA.

SPA =Sector address to be protected. Set sector address (SA) and (A₆, A₁, A₀) = (0, 1, 0).

SD =Sector protection verify data. Output 01H at protected sector addresses and output 00H at unprotected sector addresses.

Note:This command is valid while Fast Mode.

MB84VA2002-10/MB84VA2003-10

■ ABSOLUTE MAXIMUM RATINGS

Storage Temperature	-55°C to +125°C
Ambient Temperature with Power Applied	-25°C to +85°C
Voltage with Respect to Ground All pins (Note)	-0.3 V to $V_{ccf} + 0.5$ V
	-0.3 V to $V_{ccs} + 0.5$ V
V_{ccf}/V_{ccs} Supply (Note)	-0.3 V to +4.6 V

Note: Minimum DC voltage on input or I/O pins are -0.5 V. During voltage transitions, inputs may negativeovershoot V_{ss} to -2.0 V for periods of up to 20 ns. Maximum DC voltage on output and I/O pins are $V_{ccf} + 0.5$ V or $V_{ccs} + 0.5$ V. During voltage transitions, outputs may positive overshoot to $V_{cc} + 2.0$ V for periods of up to 20 ns.

WARNING: Semiconductor devices can be permanently damaged by application of stress (voltage, current, temperature, etc.) in excess of absolute maximum ratings. Do not exceed these ratings.

■ RECOMMENDED OPERATING RANGES

Commercial Devices

Ambient Temperature (T_A)

-20°C to +85°C

V_{ccf}/V_{ccs} Supply Voltages.....

+2.7 V to +3.6 V

Operating ranges define those limits between which the functionality of the device is guaranteed.

WARNING: Recommended operating conditions are normal operating ranges for the semiconductor device. All the device's electrical characteristics are warranted when operated within these ranges.

Always use semiconductor devices within the recommended operating conditions. Operation outside these ranges may adversely affect reliability and could result in device failure.

No warranty is made with respect to uses, operating conditions, or combinations not represented on the data sheet. Users considering application outside the listed conditions are advised to contact their FUJITSU representative beforehand.

MB84VA2002-10/MB84VA2003-10

■ DC CHARACTERISTICS

Parameter Symbol	Parameter Description	Test Conditions		Min.	Typ.	Max.	Unit	
I _{LI}	Input Leakage Current	—		-1.0	—	+1.0	μA	
I _{LO}	Output Leakage Current	—		-1.0	—	+1.0	μA	
I _{CC1f}	Flash V _{CC} Active Current (Read)	V _{CCf} = V _{CC} Max., \overline{CEf} = V _{IL} , \overline{OE} = V _{IH}	Byte	t _{CYCLE} = 10 MHz	—	—	22	mA
			Word		—	—	25	
			Byte	t _{CYCLE} = 5 MHz	—	—	12	
			Word		—	—	15	
I _{CC2f}	Flash V _{CC} Active Current (Program/Erase)	V _{CCf} = V _{CC} Max., \overline{CEf} = V _{IL} , \overline{OE} = V _{IH}		—	—	35	mA	
I _{CC1S}	SRAM V _{CC} Active Current	V _{CCS} = V _{CC} Max., $\overline{CE1s}$ = V _{IL} , $\overline{CE2s}$ = V _{IH}	t _{CYCLE} = 10 MHz	—	—	40	mA	
			t _{CYCLE} = 1 MHz	—	—	12	mA	
I _{CC2S}	SRAM V _{CC} Active Current	$\overline{CE1s}$ = 0.2 V, $\overline{CE2s}$ = V _{CCS} - 0.2 V, \overline{WE} = V _{CCS} - 0.2 V	t _{CYCLE} = 10 MHz	—	—	35	mA	
			t _{CYCLE} = 1 MHz	—	—	6	mA	
I _{SB1f}	Flash V _{CC} Standby Current	V _{CCf} = V _{CC} Max., \overline{CEf} = V _{CCf} ± 0.3 V RESET = V _{CCf} ± 0.3 V		—	—	5	μA	
I _{SB2f}	Flash V _{CC} Standby Current (RESET)	V _{CCf} = V _{CC} Max., RESET = V _{SS} ± 0.3 V		—	—	5	μA	
I _{SB1S}	SRAM V _{CC} Standby Current	$\overline{CE1s}$ = V _{IH} or $\overline{CE2s}$ = V _{IL}		—	—	2	mA	
I _{SB2S**}	SRAM V _{CC} Standby Current	$\overline{CE1s}$ = V _{CC} - 0.2 V or $\overline{CE2s}$ = 0.2 V	V _{CCS} = 3.0 V ± 10%	T _A = 25°C	—	1	2.5	μA
				T _A = -20 to +85°C	—	—	55	μA
			V _{CCS} = 3.3 V ± 0.3 V	T _A = 25°C	—	1.5	3	μA
				T _A = -20 to +85°C	—	—	60	μA
			V _{CCS} = 3.0 V	T _A = 25°C	—	1	2	μA
				T _A = -20 to +40°C	—	—	5	μA
T _A = -20 to +85°C	—	—	—	50	μA			
V _{IL}	Input Low Level	—		-0.3	—	0.6	V	
V _{IH}	Input High Level	—		2.2	—	V _{CC} +0.3*	V	
V _{OL}	Output Low Voltage Level	I _{OL} = 2.1 mA, V _{CCf} = V _{CCS} = V _{CC} Min.		—	—	0.4	V	
V _{OH}	Output High Voltage Level	I _{OH} = -500 μA, V _{CCf} = V _{CCS} = V _{CC} Min.		V _{CC} -0.5	—	—	V	
V _{LKO}	Flash Low V _{CC} Lock-Out Voltage	—		2.3	—	2.5	V	

* : V_{CC} indicate lower of V_{CCf} or V_{CCS}** : During standby mode with $\overline{CE1s}$ = V_{CCS} - 0.2 V, CE2s should be CE2s < 0.2V or CE2s > V_{CCS} - 0.2V

MB84VA2002-10/MB84VA2003-10

■ AC CHARACTERISTICS

• CE Timing

Parameter Symbols		Description	Test Setup		-10	Unit
JEDEC	Standard					
—	t _{CCR}	CE Recover Time	—	Min.	0	ns

• Timing Diagram for alternating SRAM to Flash

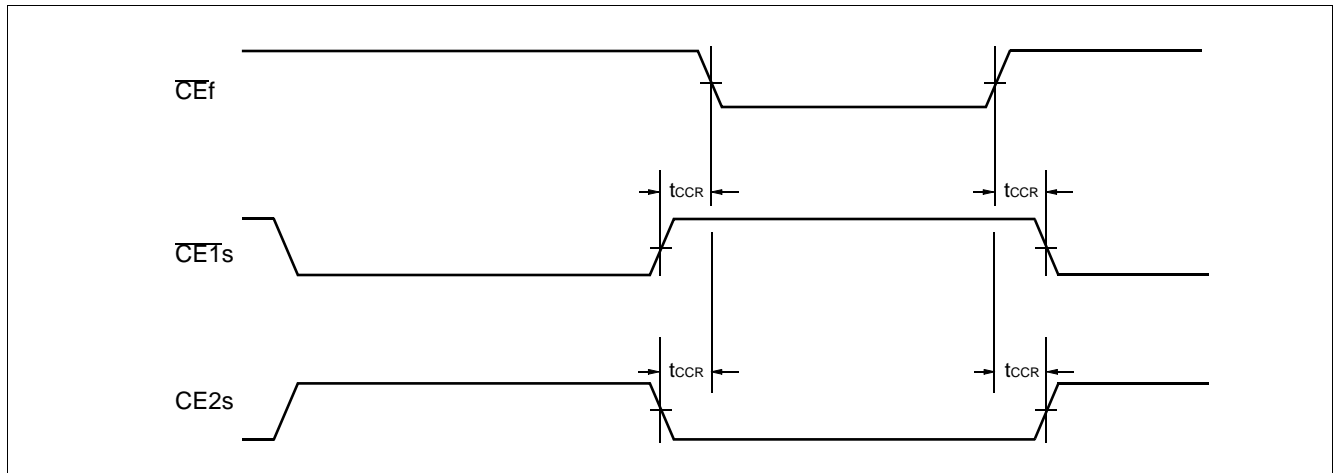

• Read Only Operations Characteristics (Flash)

Parameter Symbols		Description	Test Setup	-10 (Note)		Unit
JEDEC	Standard			Min.	Max.	
t _{AVAV}	t _{RC}	Read Cycle Time	—	100	—	ns
t _{AVQV}	t _{ACC}	Address to Output Delay	$\overline{CE}_f = V_{IL}$ $\overline{OE} = V_{IL}$	—	100	ns
t _{ELQV}	t _{CEf}	Chip Enable to Output Delay	$\overline{OE} = V_{IL}$	—	100	ns
t _{GLQV}	t _{OE}	Output Enable to Output Delay	—	—	40	ns
t _{EHQZ}	t _{DF}	Chip Enable to Output High-Z	—	—	30	ns
t _{GHQZ}	t _{DF}	Output Enable to Output High-Z	—	—	30	ns
t _{AXQX}	t _{OH}	Output Hold Time From Addresses, \overline{CE}_f or \overline{OE} , Whichever Occurs First	—	0	—	ns
—	t _{READY}	RESET Pin Low to Read Mode	—	—	20	μs
—	t _{ELFL} t _{ELFH}	CE or BYTE Switching Low or High	—	—	5	ns

Note: Test Conditions—Output Load: 1 TTL gate and 30 pF
 Input rise and fall times: 5 ns
 Input pulse levels: 0.0 V to 3.0 V
 Timing measurement reference level
 Input: 1.5 V
 Output: 1.5 V

MB84VA2002-10/MB84VA2003-10

• Read Cycle (Flash)

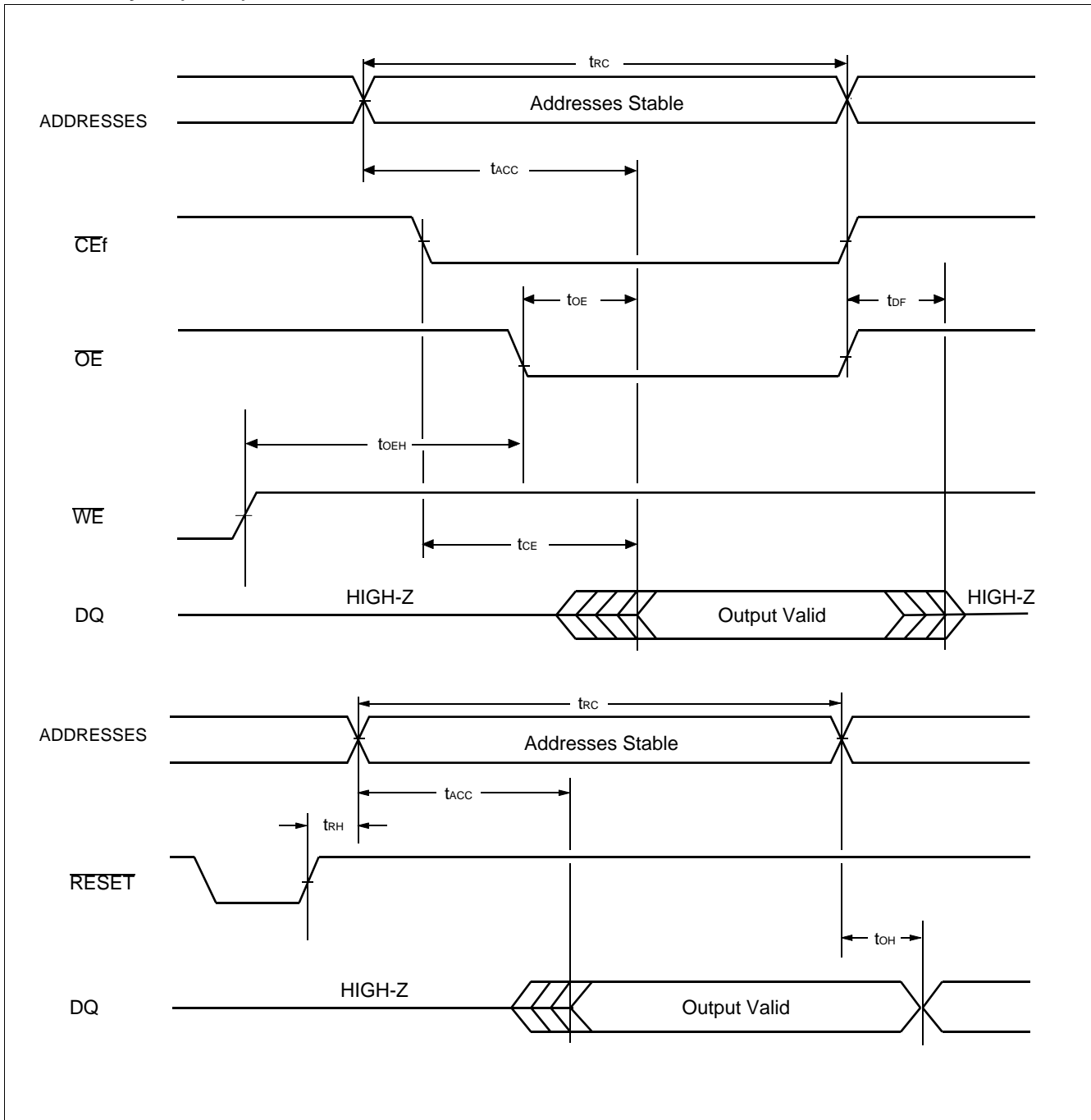

MB84VA2002-10/MB84VA2003-10

• Erase/Program Operations (Flash)

Parameter Symbols		Description	-10			Unit
JEDEC	Standard		Min.	Typ.	Max.	
t _{AVAV}	t _{WC}	Write Cycle Time	100	—	—	ns
t _{AVWL}	t _{AS}	Address Setup Time (\overline{WE} to Addr.)	0	—	—	ns
t _{AVEL}	t _{AS}	Address Setup Time (\overline{CEf} to Addr.)	0	—	—	ns
t _{WLAX}	t _{AH}	Address Hold Time (\overline{WE} to Addr.)	50	—	—	ns
t _{ELAX}	t _{AH}	Address Hold Time (\overline{CEf} to Addr.)	50	—	—	ns
t _{DVWH}	t _{DS}	Data Setup Time	50	—	—	ns
t _{WHDX}	t _{DH}	Data Hold Time	0	—	—	ns
—	t _{OES}	Output Enable Setup Time	0	—	—	ns
—	t _{OEH}	Output Enable Hold Time	0	—	—	ns
		Toggle and Data Polling	10	—	—	ns
t _{GHEL}	t _{GHEL}	Read Recover Time Before Write (\overline{OE} to \overline{CEf})	0	—	—	ns
t _{GHWL}	t _{GHWL}	Read Recover Time Before Write (\overline{OE} to \overline{WE})	0	—	—	ns
t _{WLEL}	t _{WS}	\overline{WE} Setup Time (\overline{CEf} to \overline{WE})	0	—	—	ns
t _{ELWL}	t _{CS}	\overline{CEf} Setup Time (\overline{WE} to \overline{CEf})	0	—	—	ns
t _{EHWH}	t _{WH}	\overline{WE} Hold Time (\overline{CEf} to \overline{WE})	0	—	—	ns
t _{WHEH}	t _{CH}	\overline{CEf} Hold Time (\overline{WE} to \overline{CEf})	0	—	—	ns
t _{WLWH}	t _{WP}	Write Pulse Width	50	—	—	ns
t _{ELEH}	t _{CP}	\overline{CEf} Pulse Width	50	—	—	ns
t _{WHWL}	t _{WPH}	Write Pulse Width High	30	—	—	ns
t _{EHEL}	t _{CPH}	\overline{CEf} Pulse Width High	30	—	—	ns
t _{WHWH1}	t _{WHWH1}	Byte Programming Operation	—	8	—	μs
t _{WHWH2}	t _{WHWH2}	Sector Erase Operation (Note 1)	—	1	—	sec
			—	—	15	sec
—	t _{VCS}	V _{ccf} Setup Time	50	—	—	μs
—	t _{VLHT}	Voltage Transition Time (Note 2)	4	—	—	μs
—	t _{VIDR}	Rise Time to V _{ID} (Note 2)	500	—	—	ns
—	t _{RB}	Recover Time from RY/BY	0	—	—	ns
—	t _{RP}	RESET Pulse Width	500	—	—	ns
—	t _{RH}	RESET Hold Time Before Read	200	—	—	ns
—	t _{EOE}	Delay Time from Embedded Output Enable	—	—	100	ns
—	t _{BUSY}	Program/Erase Valid to RY/BY Delay	—	—	90	ns
—	t _{FLQZ}	BYTE Switching Low to Output High-Z	—	—	30	ns
—	t _{FLQV}	BYTE Switching High to Output Active	30	—	—	ns

Note : 1. This does not include the preprogramming time.

2. This timing is for Sector Protection Operation.

MB84VA2002-10/MB84VA2003-10

• Write Cycle (WE control) (Flash)

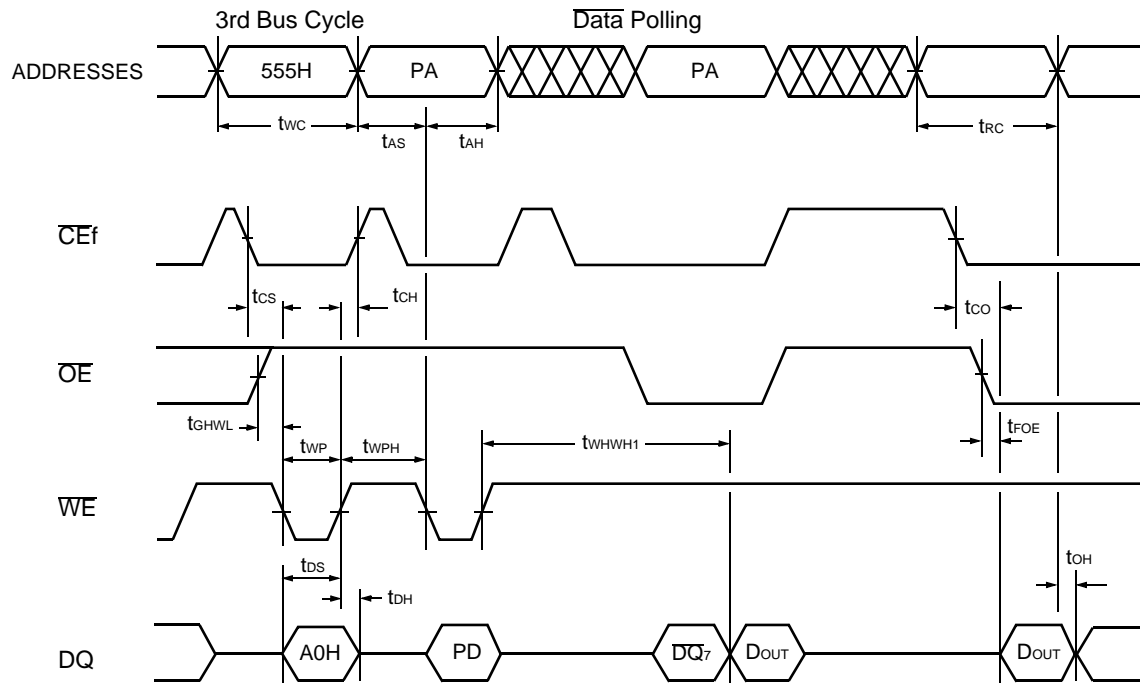

- Notes:**
1. PA is address of the memory location to be programmed.
 2. PD is data to be programmed at byte address.
 3. \overline{DQ}_7 is the output of the complement of the data written to the device.
 4. DOUT is the output of the data written to the device.
 5. Figure indicates last two bus cycles out of four cycle sequence
 6. These waveforms are for the x16 mode. The addresses differ from x8 mode.

MB84VA2002-10/MB84VA2003-10

• Write Cycle (\overline{CEf} control) (Flash)

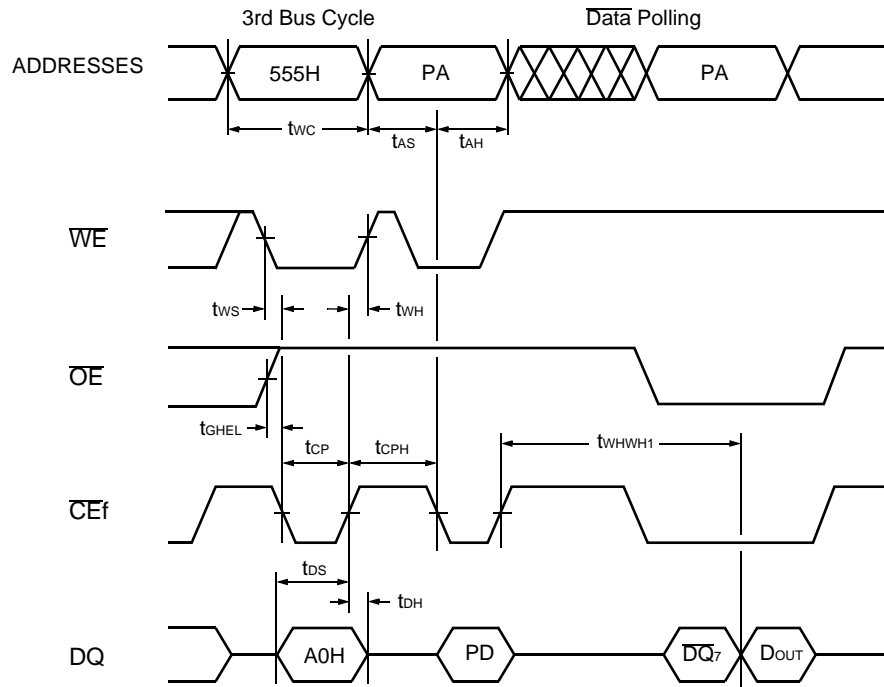

- Notes:**
1. PA is address of the memory location to be programmed.
 2. PD is data to be programmed at byte address.
 3. \overline{DQ}_7 is the output of the complement of the data written to the device.
 4. DOUT is the output of the data written to the device.
 5. Figure indicates last two bus cycles out of four bus cycle sequence
 6. These waveforms are for the x16 mode. The addresses differ from x8 mode.

MB84VA2002-10/MB84VA2003-10

• AC Waveforms Chip/Sector Erase Operations (Flash)

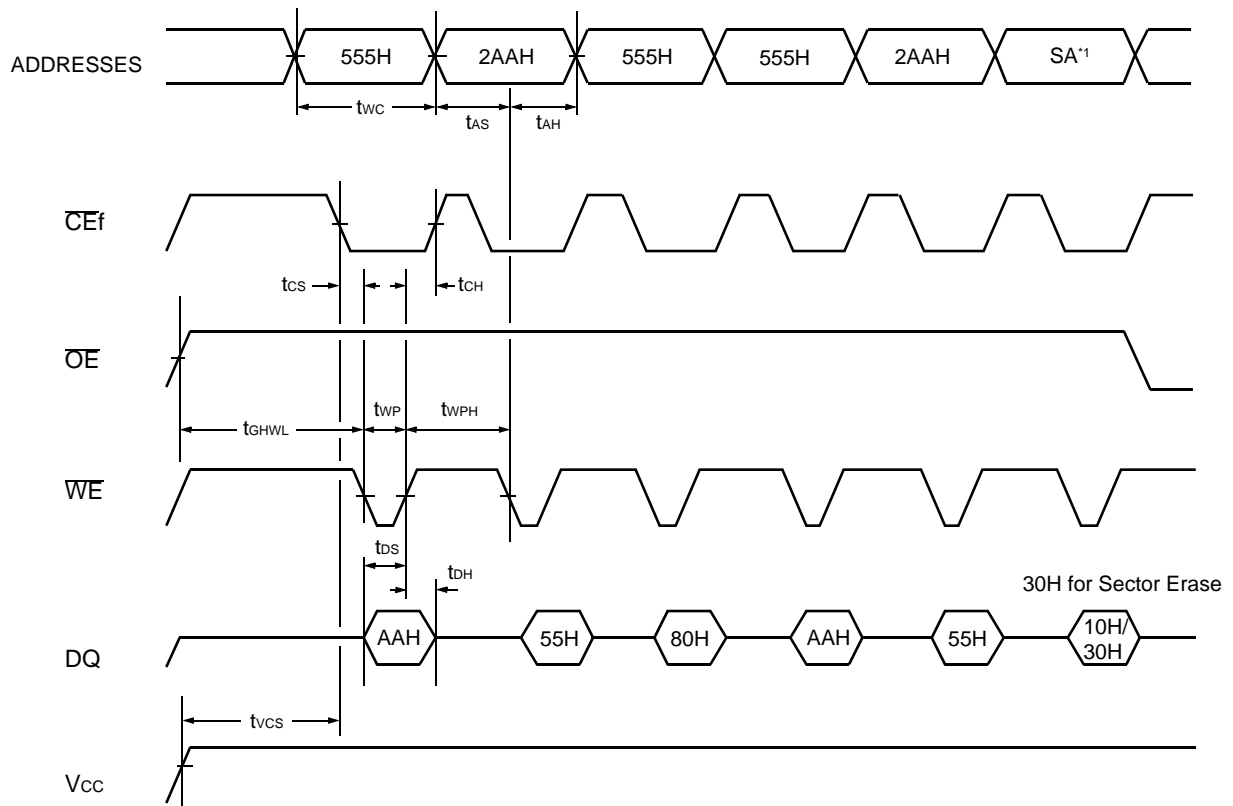

- Notes:**
1. SA is the sector address for Sector Erase. Addresses = 555H for Chip Erase.
 2. These waveforms are for the x16 mode. The addresses differ from x8 mode.

MB84VA2002-10/MB84VA2003-10

• AC Waveforms for Data Polling during Embedded Algorithm Operations (Flash)

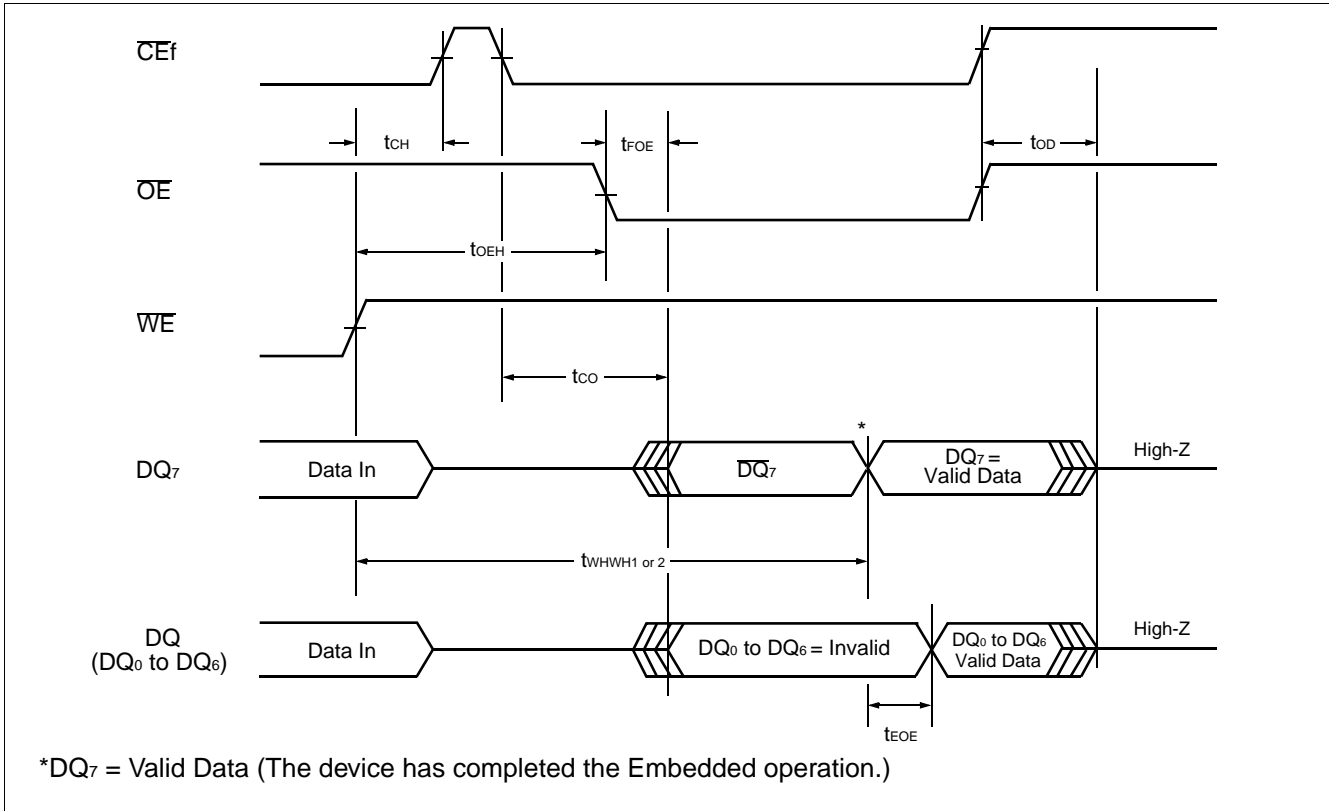

• AC Waveforms for Taggle Bit during Embedded Algorithm Operations (Flash)

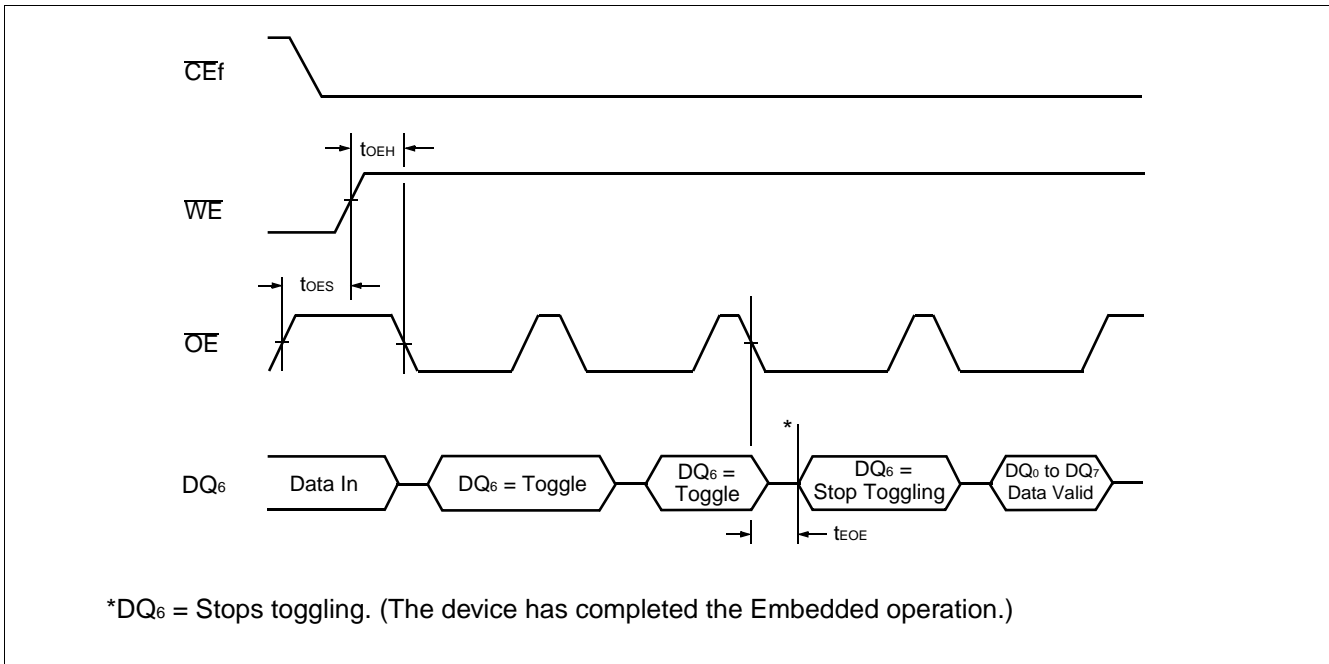

MB84VA2002-10/MB84VA2003-10

• RY/BY Timing Diagram during Write/Erase Operations (Flash)

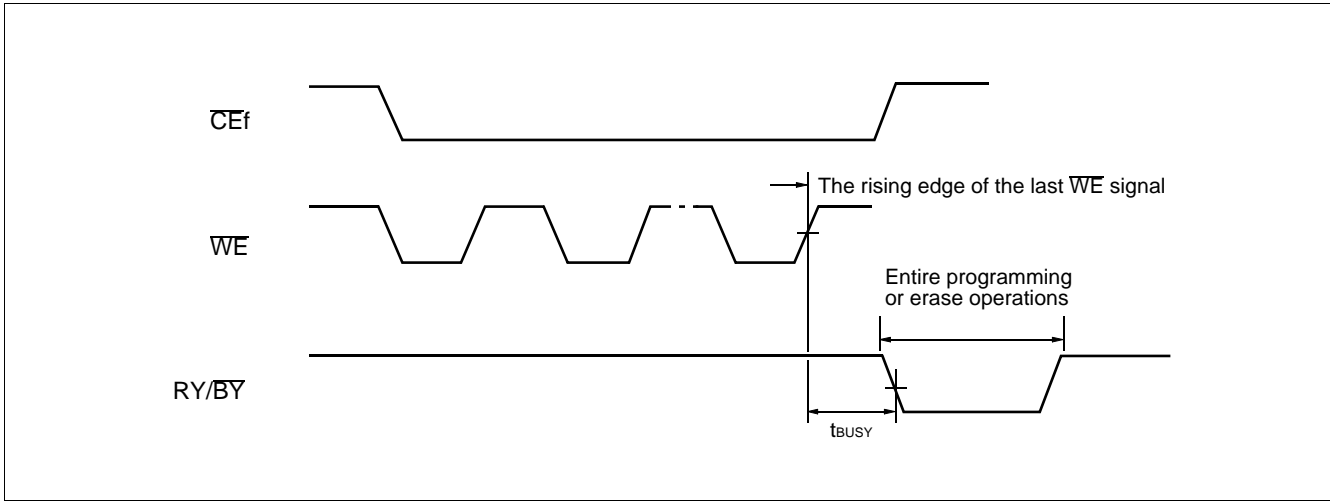

• RESET, RY/BY Timing Diagram (Flash)

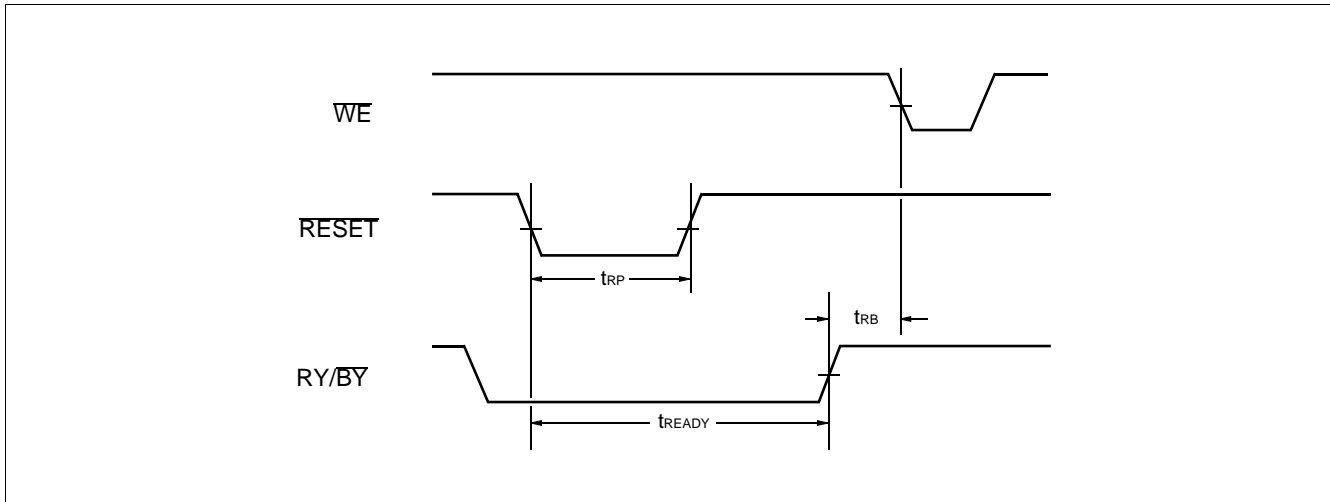

• Timing Diagram for Word Mode Configuration (Flash)

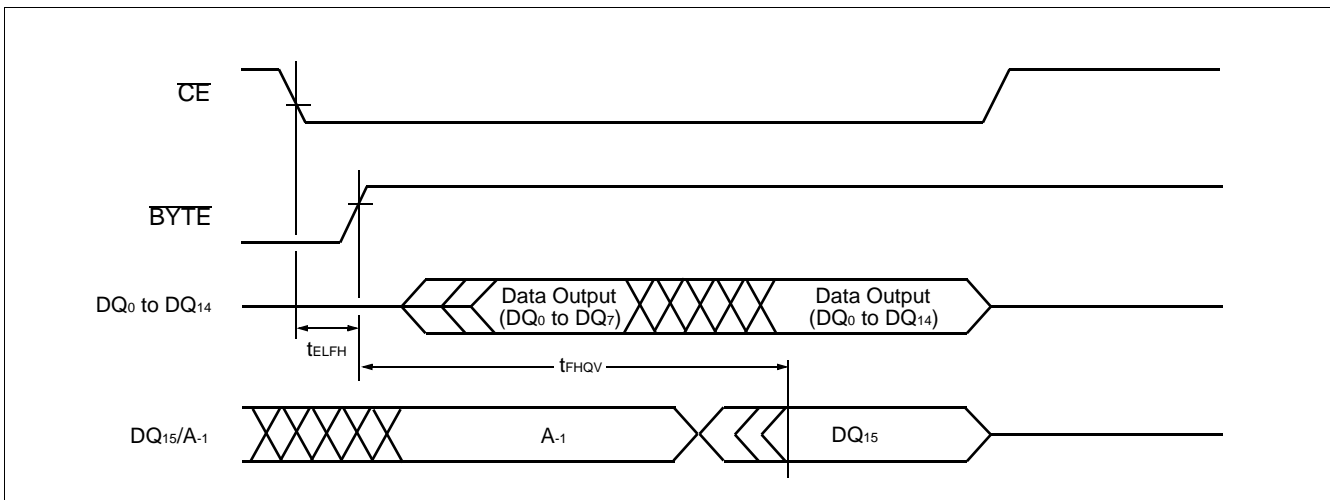

MB84VA2002-10/MB84VA2003-10

• Timing Diagram for Byte Mode Configuration (Flash)

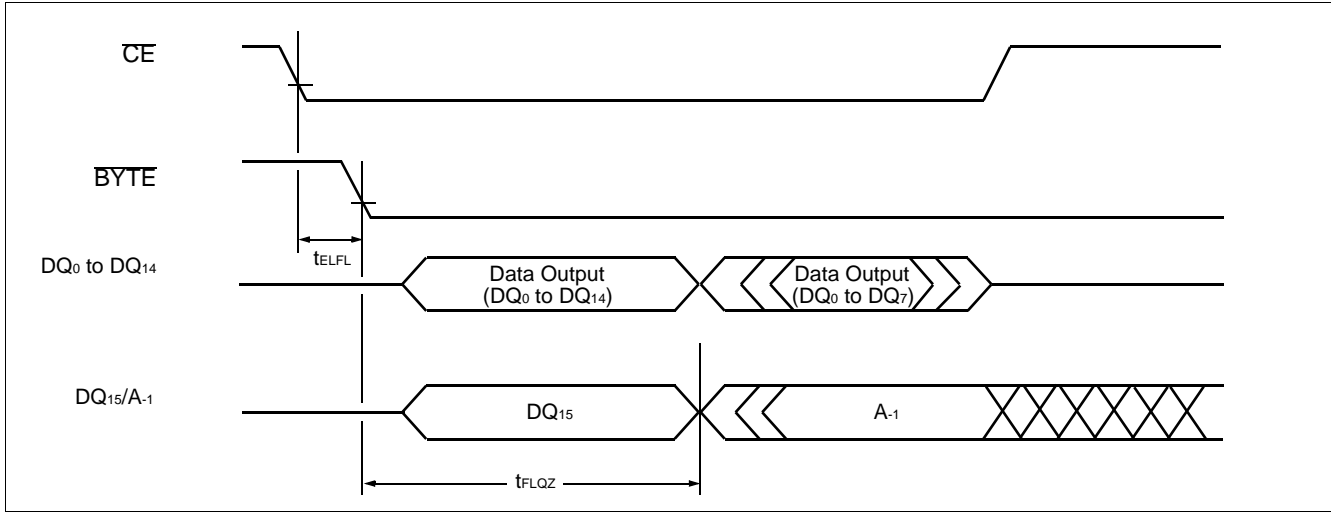

• BYTE Timing Diagram for Write Operations (Flash)

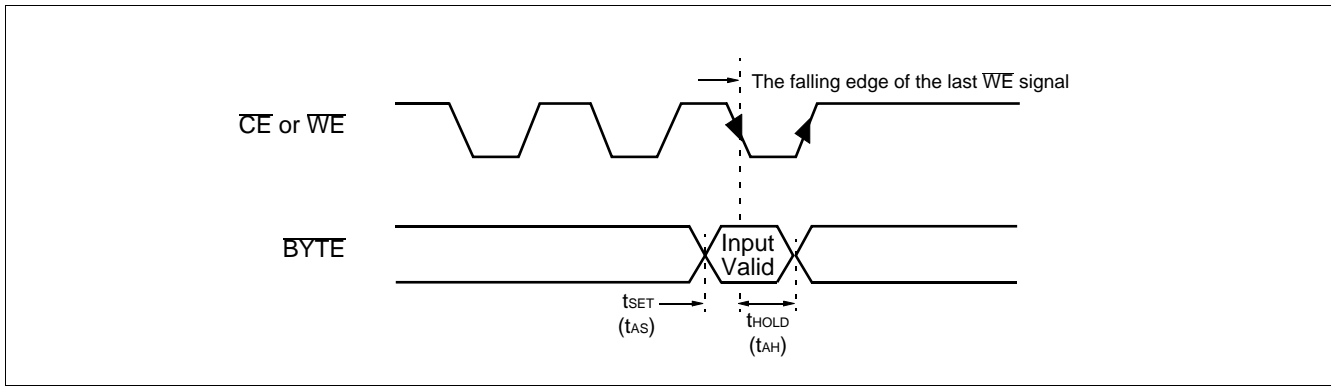

• Temporary Sector Unprotection (Flash)

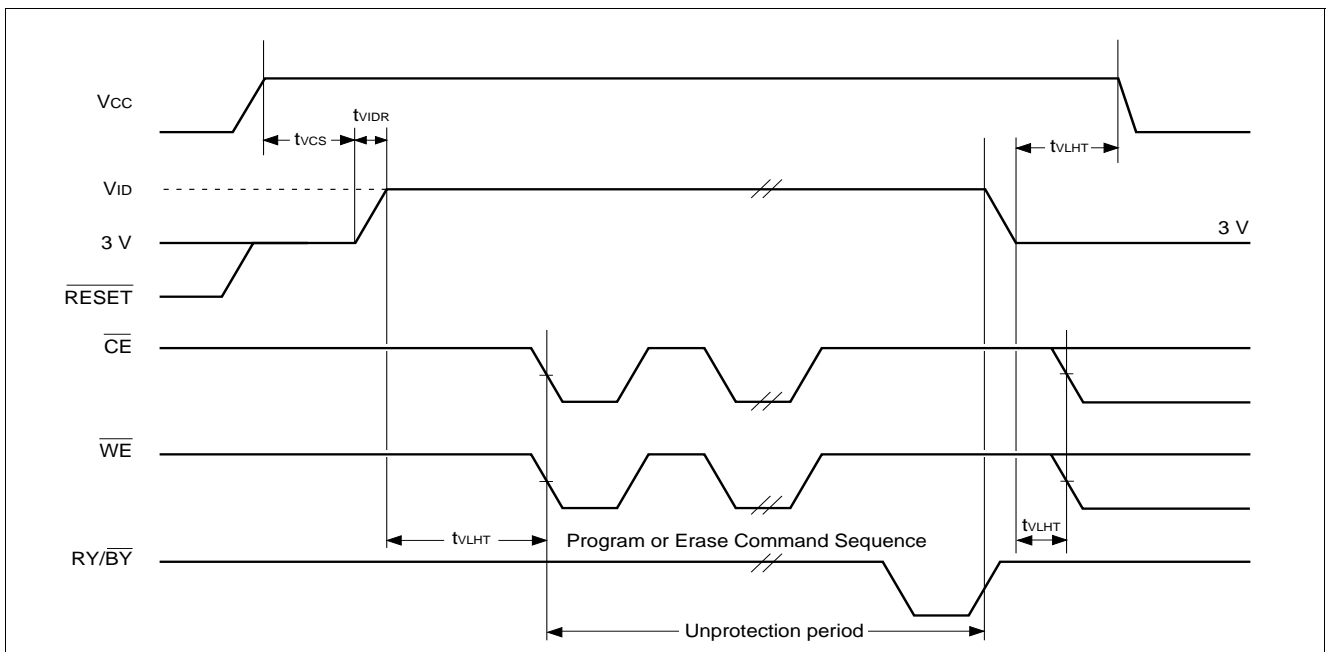

MB84VA2002-10/MB84VA2003-10

• Extended Sector Protection (Flash)

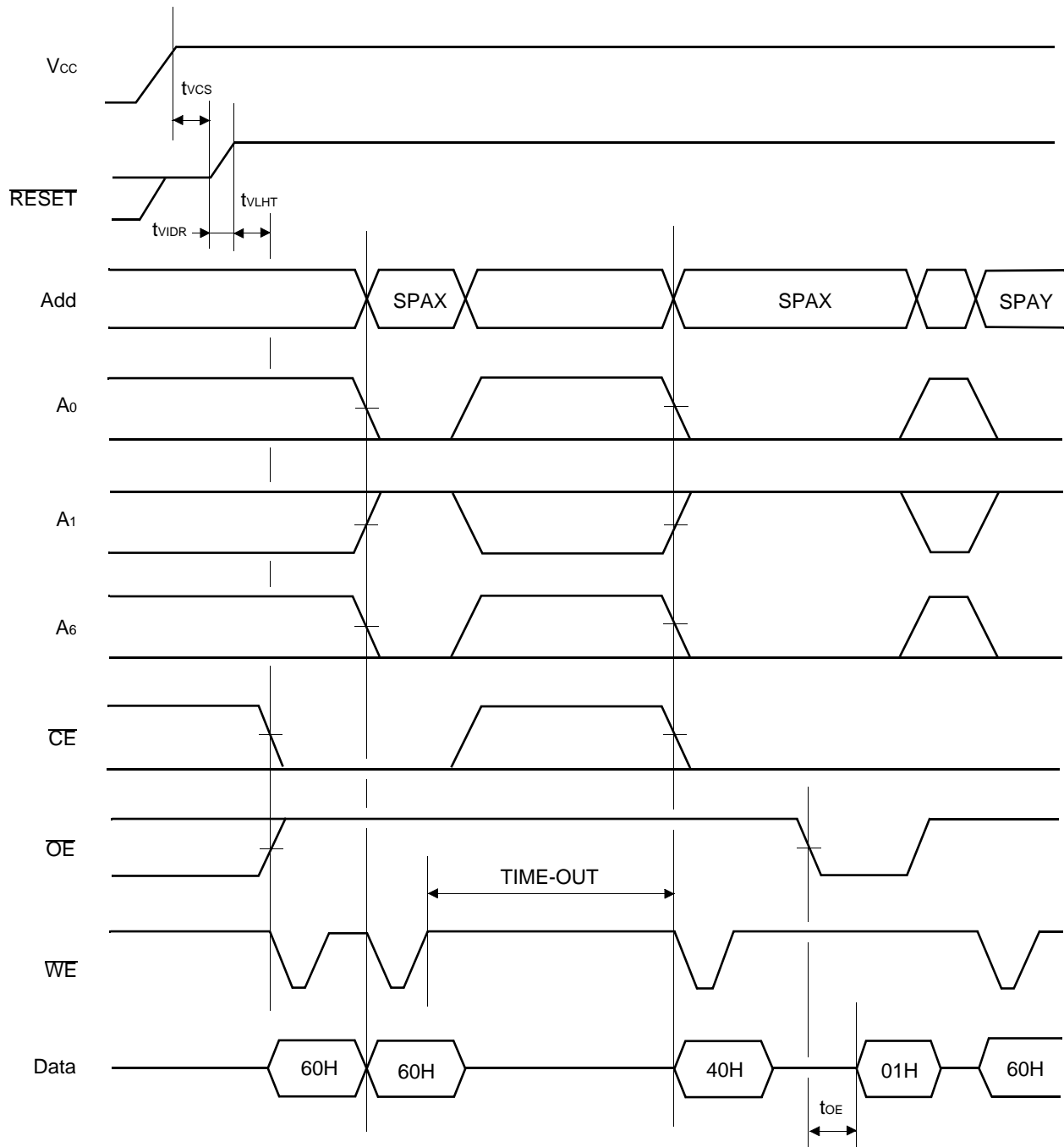

SPAX : Sector Address to be protected
 SPAY : Next Sector Address to be protected
 TIME-OUT : Time-Out window = 150 μ s (min)

MB84VA2002-10/MB84VA2003-10

• Read Cycle (SRAM)

Parameter Symbol	Parameter Description	Min.	Max.	Unit
t_{RC}	Read Cycle Time	100	—	ns
t_{AA}	Address Access Time	—	100	ns
t_{CO1}	Chip Enable ($\overline{CE1}$ s) Access Time	—	100	ns
t_{CO2}	Chip Enable ($CE2$ s) Access Time	—	100	ns
t_{OE}	Output Enable Access Time	—	50	ns
t_{COE}	Chip Enable ($\overline{CE1}$ s Low and $CE2$ s High) to Output Active	5	—	ns
t_{OEE}	Output Enable Low to Output Active	0	—	ns
t_{OD}	Chip Enable ($\overline{CE1}$ s High or $CE2$ s Low) to Output High-Z	—	40	ns
t_{ODO}	Output Enable High to Output High-Z	—	40	ns
t_{OH}	Output Data Hold Time	10	—	ns

• Read Cycle (Note 1) (SRAM)

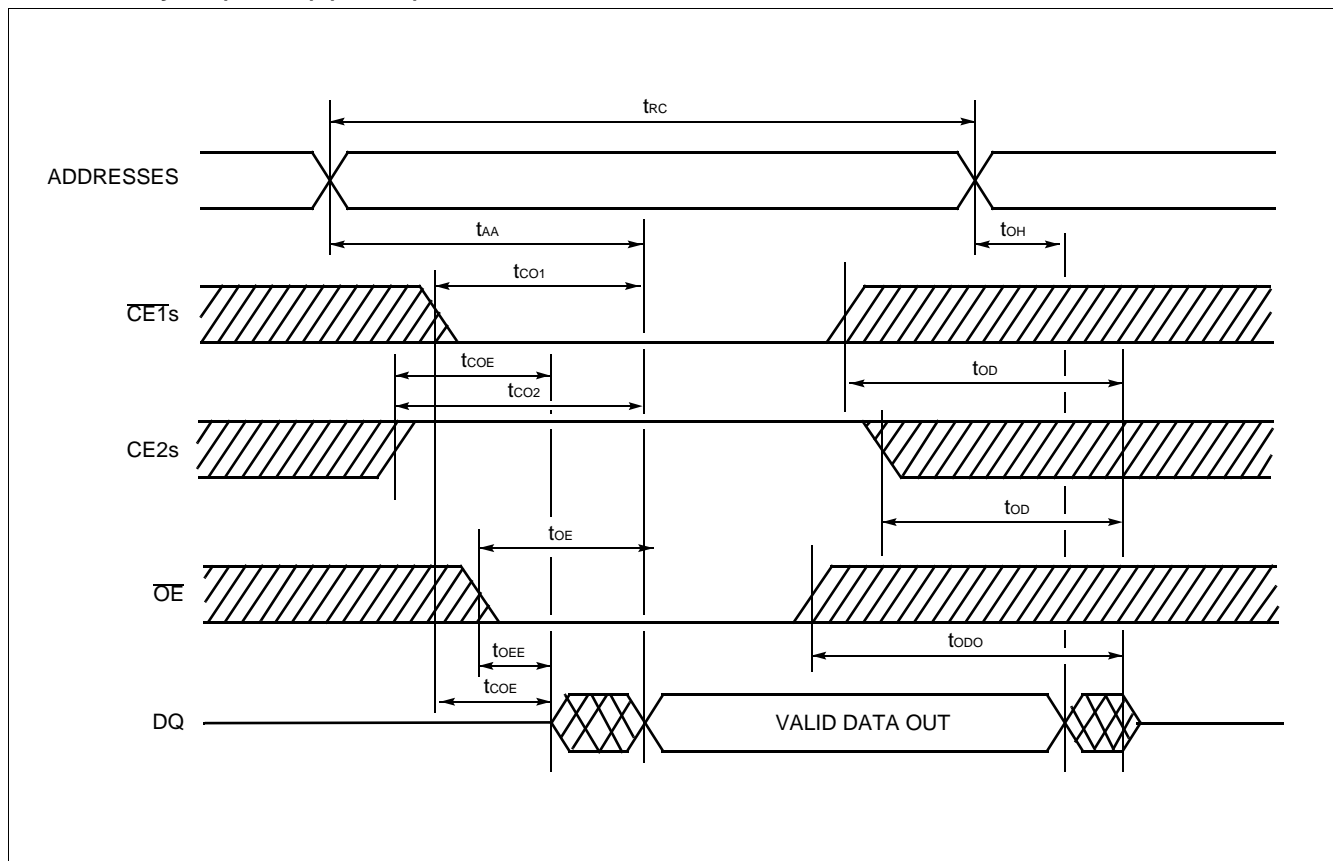

Note: 1. \overline{WE} remains HIGH for the read cycle.

MB84VA2002-10/MB84VA2003-10

• Write Cycle (SRAM)

Parameter Symbol	Parameter Description	Min.	Max.	Unit
t_{WC}	Write Cycle Time	100	—	ns
t_{WP}	Write Pulse Width	60	—	ns
t_{CW}	Chip Enable to End of Write	80	—	ns
t_{AS}	Address Setup Time	0	—	ns
t_{WR}	Write Recovery Time	0	—	ns
t_{ODW}	\overline{WE} Low to Output High-Z	—	40	ns
t_{OEW}	\overline{WE} High to Output Active	0	—	ns
t_{DS}	Data Setup Time	40	—	ns
t_{DH}	Data Hold Time	0	—	ns

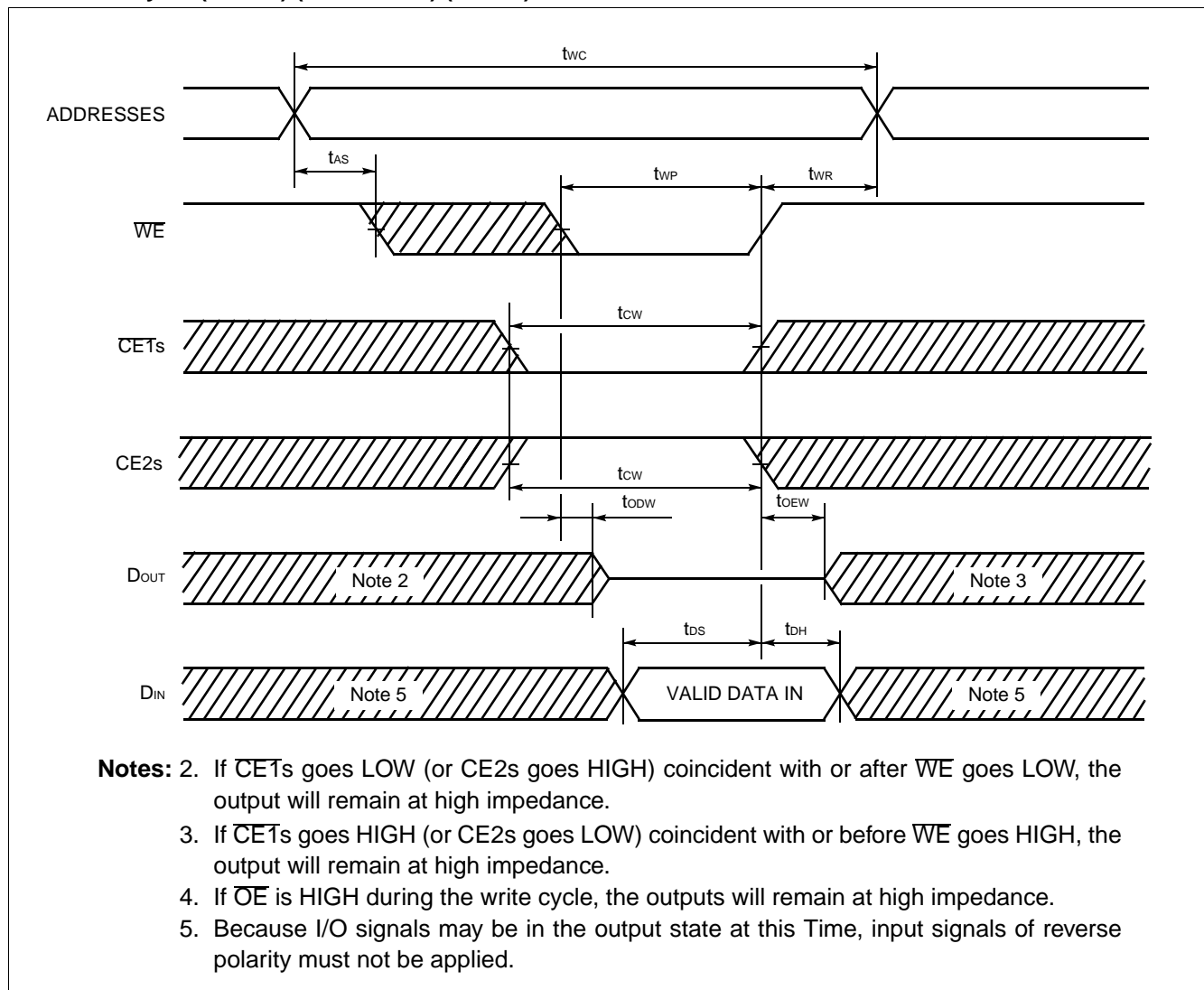
• Write Cycle (Note 4) (\overline{WE} control) (SRAM)

MB84VA2002-10/MB84VA2003-10

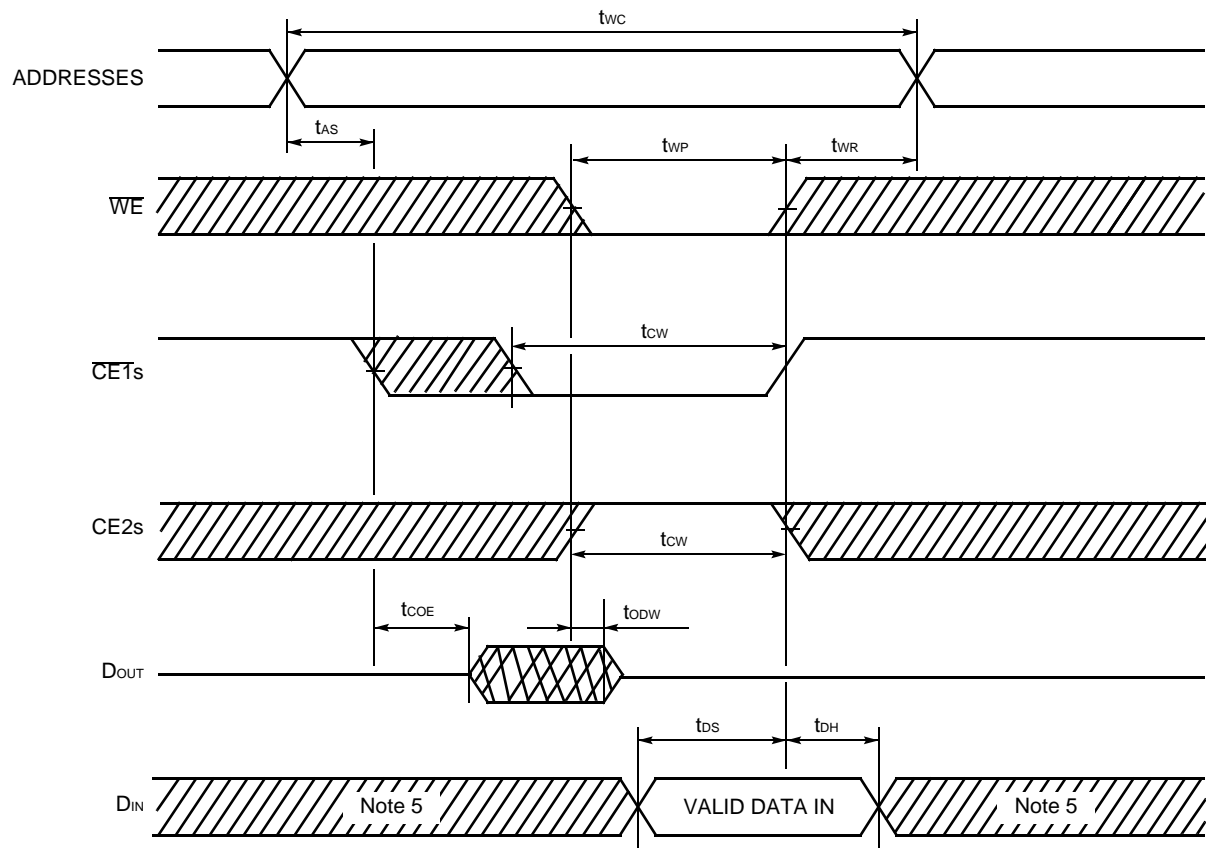
• Write Cycle (Note 4) ($\overline{CE1s}$ control) (SRAM)

- Notes:**
2. If $\overline{CE1s}$ goes LOW (or CE2s goes HIGH) coincident with or after \overline{WE} goes LOW, the output will remain at high impedance.
 3. If $\overline{CE1s}$ goes HIGH (or CE2s goes LOW) coincident with or before \overline{WE} goes HIGH, the output will remain at high impedance.
 4. If \overline{OE} is HIGH during the write cycle, the outputs will remain at high impedance.
 5. Because I/O signals may be in the output state at this Time, input signals of reverse polarity must not be applied.

MB84VA2002-10/MB84VA2003-10

• Write Cycle (Note 4) (CE2s Control) (SRAM)

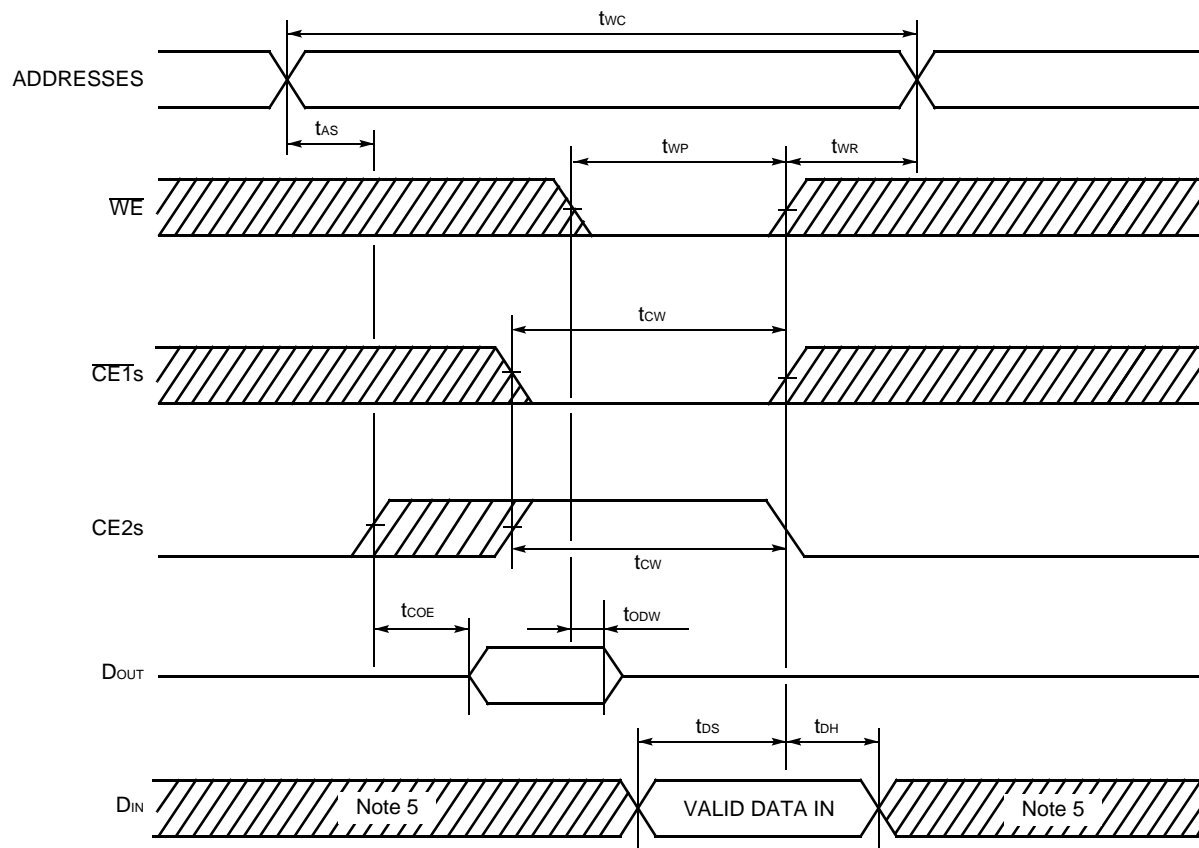

- Notes:**
2. If $\overline{CE1s}$ goes LOW (or $CE2s$ goes HIGH) coincident with or after \overline{WE} goes LOW, the output will remain at high impedance.
 3. If $\overline{CE1s}$ goes HIGH (or $CE2s$ goes LOW) coincident with or before \overline{WE} goes HIGH, the output will remain at high impedance.
 4. If \overline{OE} is HIGH during the write cycle, the outputs will remain at high impedance.
 5. Because I/O signals may be in the output state at this Time, input signals of reverse polarity must not be applied.

MB84VA2002-10/MB84VA2003-10

■ ERASE AND PROGRAMMING PERFORMANCE (Flash)

Parameter	Limits			Unit	Comment
	Min.	Typ.	Max.		
Sector Erase Time	—	1	15	sec	Excludes programming time prior to erasure
Byte Programming Time	—	8	3,600	μs	Excludes system-level overhead
Chip Programming Time	—	12	T.B.D	sec	Excludes system-level overhead
Erase/Program Cycle	100,000	—	—	cycles	

■ DATA RETENTION CHARACTERISTICS (SRAM)

Parameter Symbol	Parameter Description	Min.	Typ.	Max.	Unit
V_{DH}	Data Retention Supply Voltage	2.0	—	3.6	V
I_{DDs2}	Standby Current	$V_{DH} = 3.0\text{ V}$	—	50*	μA
		$V_{DH} = 3.6\text{ V}$	—	60	μA
t_{CDR}	Chip Deselect to Data Retention Mode Time	0	—	—	ns
t_R	Recovery Time	5	—	—	ms

* : 5 μA (Max.) at $T_A = -20^\circ\text{C}$ to $+40^\circ\text{C}$

• $\overline{CE1}$ s Controlled Data Retention Mode (Note 1)

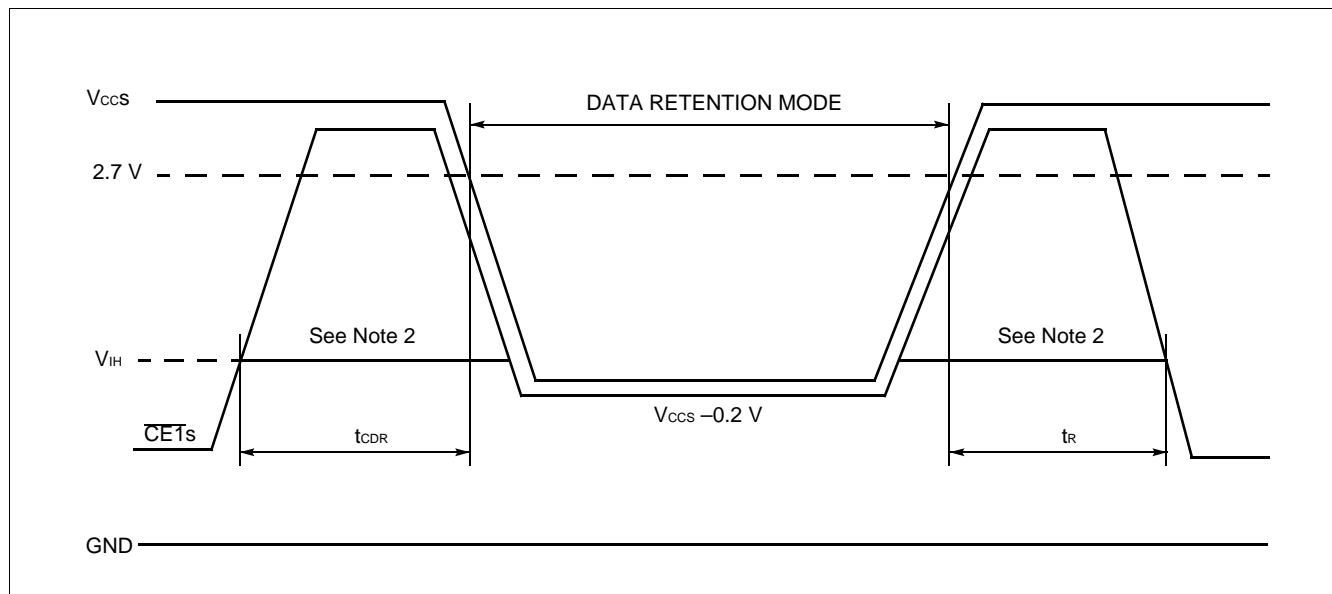

MB84VA2002-10/MB84VA2003-10

• CE2s Controlled Data Retention Mode (Note 3)

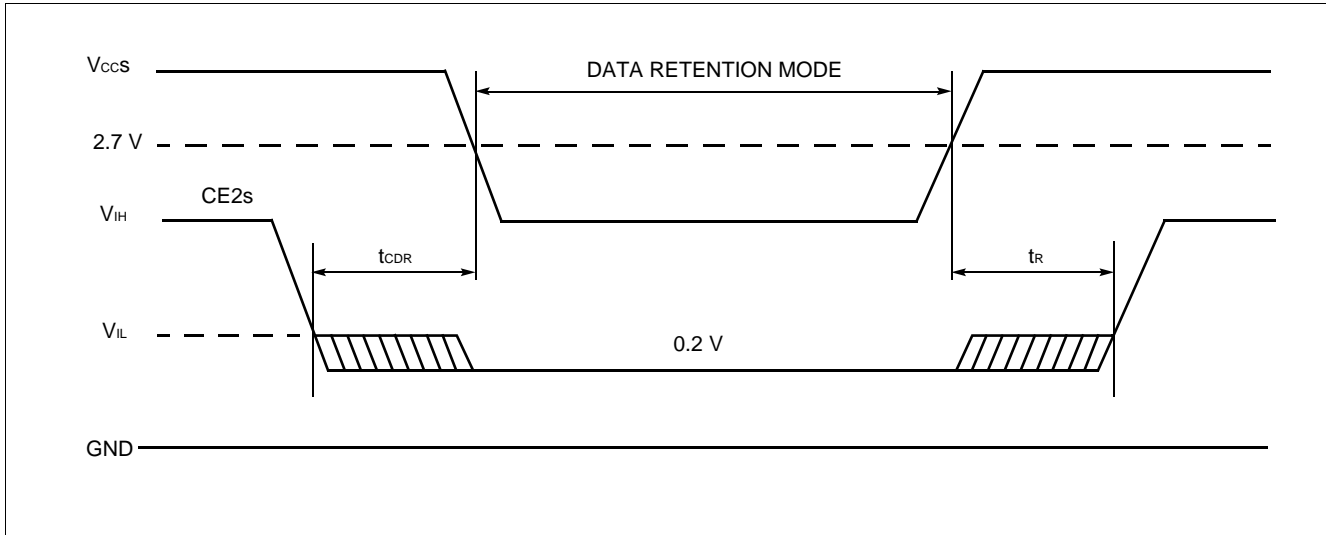

- Notes:**
1. In $\overline{CE1}$ s controlled data retention mode, input level of CE2s should be fixed V_{CCS} to $V_{CCS}-0.2V$ or V_{SS} to $0.2V$ during data retention mode. Other input and input/output pins can be used between $-0.3V$ to $V_{CCS}+0.3V$.
 2. When $\overline{CE1}$ s is operating at the V_{IH} min. level ($2.2V$), the standby current is given by I_{SB1S} during the transition of V_{CCS} from 3.6 to $2.2V$.
 3. In CE2s controlled data retention mode, input and input/output pins can be used between between $-0.3V$ to $V_{CCS}+0.3V$.

■ PIN CAPACITANCE

Parameter Symbol	Parameter Description	Test Setup	Typ.	Max.	Unit
C_{IN}	Input Capacitance	$V_{IN} = 0$	T.B.D	T.B.D	pF
C_{OUT}	Output Capacitance	$V_{OUT} = 0$	T.B.D	T.B.D	pF
C_{IN2}	Control Pin Capacitance	$V_{IN} = 0$	T.B.D	T.B.D	pF

Note: Test conditions $T_A = 25^\circ C$, $f = 1.0$ MHz

■ HANDLING OF PACKAGE

Please handle this package carefully since the sides of packages are right angle.

■ CAUTION

- 1.)The high voltage (VID) can not apply to address pins and control pins except \overline{RESET} . Therefore, it can not use autoselect and sector protect function by applying the high voltage (VID) to specific pins.
- 2.)For the sector protection, since the high voltage (VID) can be applied to the \overline{RESET} , it can be protected the sector using "Extended sector protect" command.

MB84VA2002-10/MB84VA2003-10

■ PACKAGE

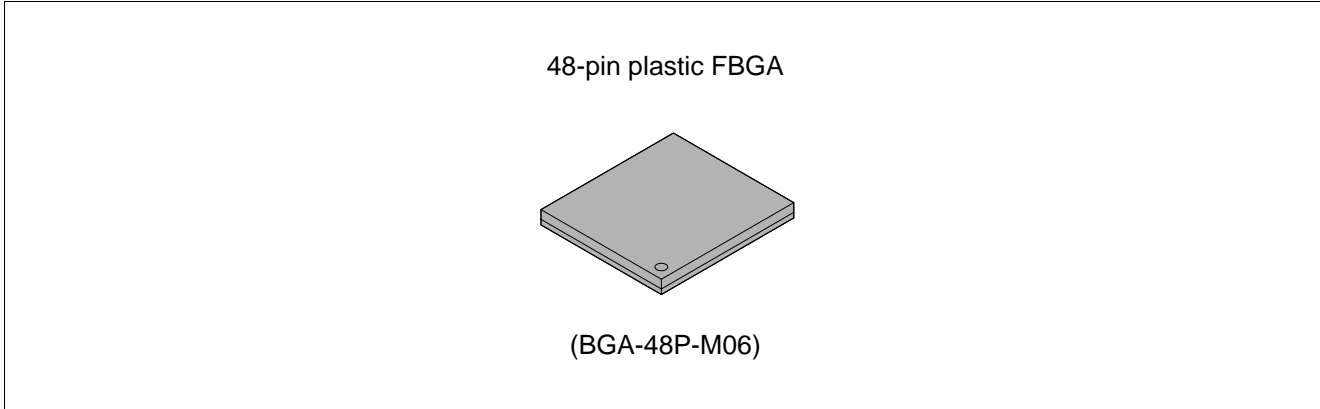

■ PACKAGE DIMENSIONS

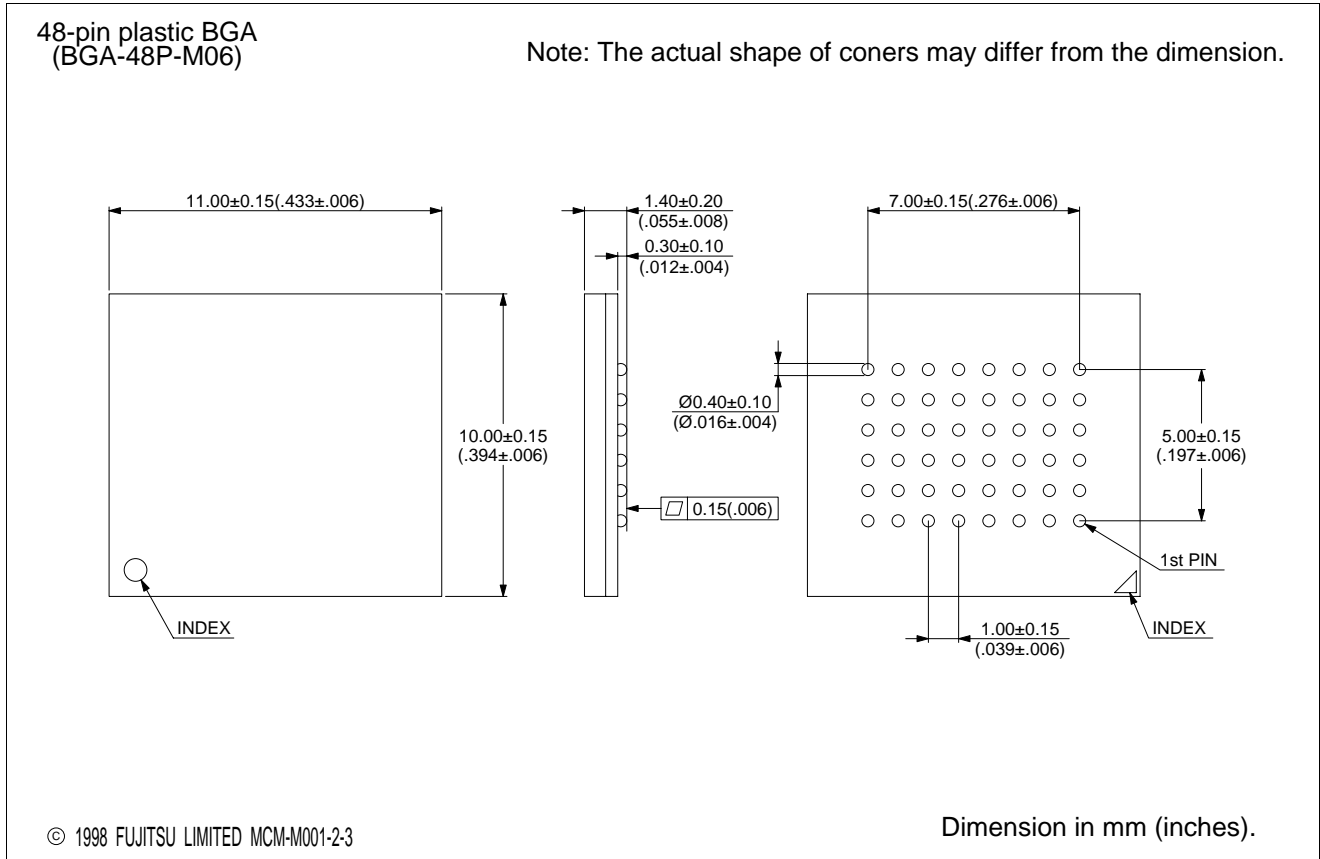

MB84VA2002-10/MB84VA2003-10

FUJITSU LIMITED

For further information please contact:

Japan

FUJITSU LIMITED
Corporate Global Business Support Division
Electronic Devices
KAWASAKI PLANT, 4-1-1, Kamikodanaka
Nakahara-ku, Kawasaki-shi
Kanagawa 211-8588, Japan
Tel: (044) 754-3763
Fax: (044) 754-3329

<http://www.fujitsu.co.jp/>

North and South America

FUJITSU MICROELECTRONICS, INC.
Semiconductor Division
3545 North First Street
San Jose, CA 95134-1804, USA
Tel: (408) 922-9000
Fax: (408) 922-9179

Customer Response Center
Mon. - Fri.: 7 am - 5 pm (PST)
Tel: (800) 866-8608
Fax: (408) 922-9179

<http://www.fujitsumicro.com/>

Europe

FUJITSU MIKROELEKTRONIK GmbH
Am Siebenstein 6-10
D-63303 Dreieich-Buchsschlag
Germany
Tel: (06103) 690-0
Fax: (06103) 690-122

<http://www.fujitsu-edc.com/>

Asia Pacific

FUJITSU MICROELECTRONICS ASIA PTE LTD
#05-08, 151 Lorong Chuan
New Tech Park
Singapore 556741
Tel: (65) 281-0770
Fax: (65) 281-0220

<http://www.fmap.com.sg/>

F9805

© FUJITSU LIMITED Printed in Japan

All Rights Reserved.

The contents of this document are subject to change without notice. Customers are advised to consult with FUJITSU sales representatives before ordering.

The information and circuit diagrams in this document presented as examples of semiconductor device applications, and are not intended to be incorporated in devices for actual use. Also, FUJITSU is unable to assume responsibility for infringement of any patent rights or other rights of third parties arising from the use of this information or circuit diagrams.

FUJITSU semiconductor devices are intended for use in standard applications (computers, office automation and other office equipment, industrial, communications, and measurement equipment, personal or household devices, etc.).

CAUTION:

Customers considering the use of our products in special applications where failure or abnormal operation may directly affect human lives or cause physical injury or property damage, or where extremely high levels of reliability are demanded (such as aerospace systems, atomic energy controls, sea floor repeaters, vehicle operating controls, medical devices for life support, etc.) are requested to consult with FUJITSU sales representatives before such use. The company will not be responsible for damages arising from such use without prior approval.

Any semiconductor devices have inherently a certain rate of failure. You must protect against injury, damage or loss from such failures by incorporating safety design measures into your facility and equipment such as redundancy, fire protection, and prevention of over-current levels and other abnormal operating conditions.

If any products described in this document represent goods or technologies subject to certain restrictions on export under the Foreign Exchange and Foreign Trade Control Law of Japan, the prior authorization by Japanese government should be required for export of those products from Japan.