



FEATURES

- Supports AT&T TR62411 and Telcordia GR-1244-CORE Stratum 4 Enhanced and Stratum 4 timing for DS1 interfaces
- Supports ETSI ETS 300 011, TBR 4, TBR 12 and TBR 13 timing for E1 interface
- Selectable input reference: 8 kHz, 1.544 MHz, 2.048 MHz or 19.44 MHz
- Provides C1.5o, C3o, C2o, C4o, C6o, C8o, C16o, C19o and C32o output clock signals
- Provides 7 types of 8 kHz framing pulses: F0o, F8o, F16o, F19o, F32o, RSP and TSP
- Provides a C2/C1.5 output clock signal with the frequency controlled by the reference input Fref

- Holdover frequency accuracy of 0.00625 ppm
- Phase slope of 5 ns per 125 μs
- Attenuates wander from 2.1 Hz
- Fast lock mode
- Provides Time Interval Error (TIE) correction
- MTIE of 600 ns
- JTAG boundary scan
- Holdover status indication
- Freerun status indication
- Normal status indication
- Lock status indication
- Input reference quality indication
- 3.3 V operation with 5 V tolerant I/O
- Package available: 56-pin SSOP

FUNCTIONAL BLOCK DIAGRAM

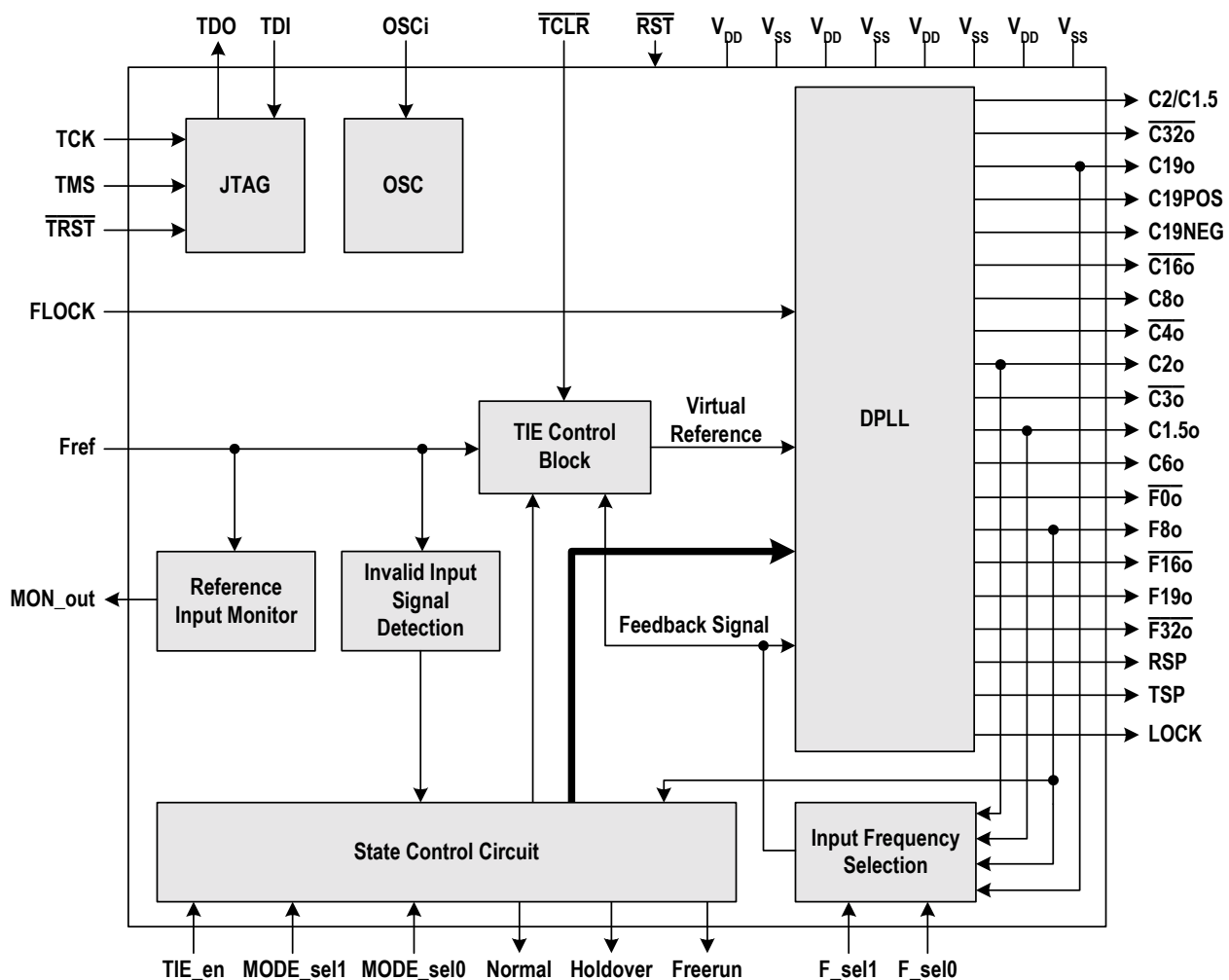

The IDT logo is a registered trademark of Integrated Device Technology, Inc.

DESCRIPTION

The IDT82V3011 is a T1/E1/OC3 WAN PLL with single reference input. It contains a Digital Phase-Locked Loop (DPLL), which generates low jitter ST-BUS and 19.44 MHz clock and framing signals that are phase locked to an 8 kHz, 1.544 MHz, 2.048 MHz or 19.44 MHz input reference.

The IDT82V3011 provides 9 types of clock signals (C1.5o, C3o, C6o, C2o, C4o, C8o, C16o, C19o, C32o) and 7 types of framing signals (F0o, F8o, F16o, F19o, F32o, RSP, TSP) for multitruunk T1/E1 and STS3/OC3 links.

The IDT82V3011 is compliant with AT&T TR62411, Telcordia GR-

1244-CORE Stratum 4 Enhanced and Stratum 4, and ETSI ETS 300 011. It meets the jitter/wander tolerance, jitter/wander transfer, intrinsic jitter/wander, frequency accuracy, capture range, phase change slope, holdover frequency accuracy and MTIE (Maximum Time Interval Error) requirements for these specifications.

The IDT82V3011 can be used in synchronization and timing control for T1, E1 and OC3 systems, or used as ST-BUS clock and frame pulse source. It also can be used in access switch, access routers, ATM edge switches, wireless base station controllers, or IADs (Integrated Access Devices), PBXs, line cards and SONET/SDH equipments.

PIN CONFIGURATION

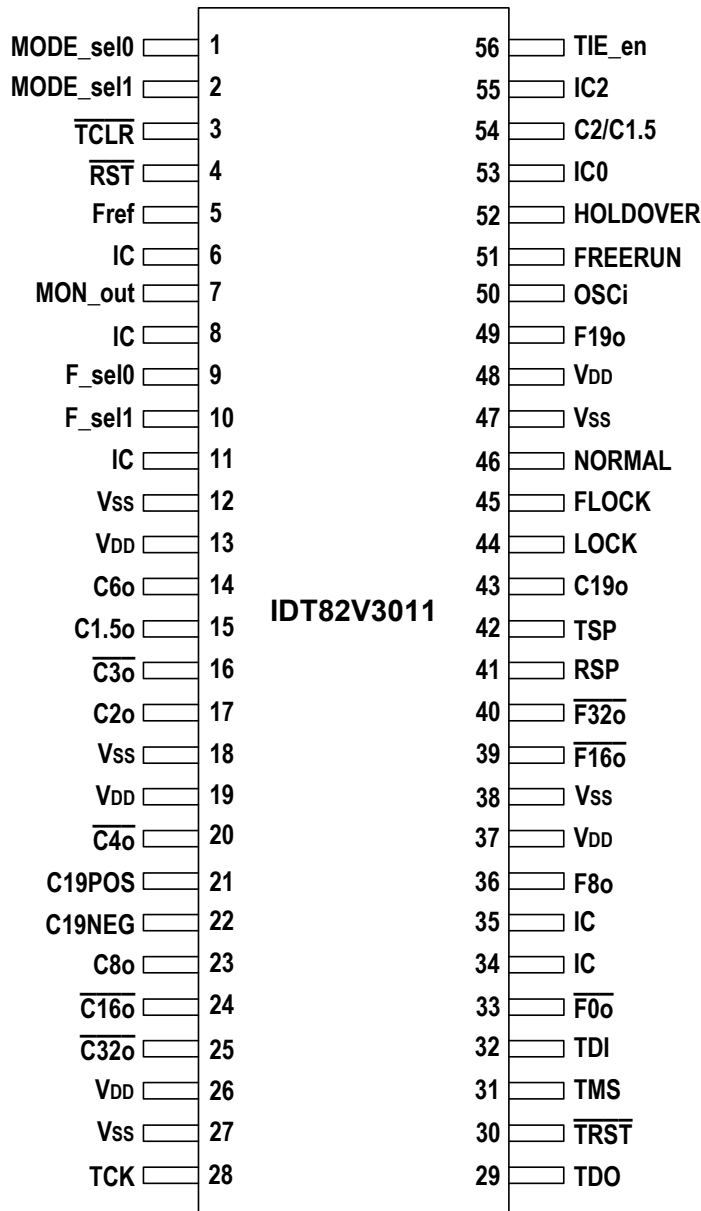

Figure - 1 IDT82V3011 SSOP56 Package Pin Assignment

TABLE OF CONTENTS

1	Pin Description	7
2	Functional Description	9
2.1	State Control Circuit.....	9
2.1.1	Normal Mode.....	10
2.1.2	Fast Lock Mode.....	10
2.1.3	Holdover Mode.....	10
2.1.4	Freerun Mode.....	10
2.2	Frequency Select Circuit.....	10
2.3	Reference Input Monitor.....	10
2.4	Invalid Input Signal Detection.....	10
2.5	TIE Control Block.....	11
2.6	DPLL Block.....	13
2.6.1	Phase Detector (PHD).....	13
2.6.2	Limiter.....	13
2.6.3	Loop Filter.....	13
2.6.4	Fraction Block.....	13
2.6.5	Digital Control Oscillator (DCO).....	13
2.6.6	Lock Indicator.....	13
2.6.7	Output Interface.....	13
2.7	OSC.....	13
2.7.1	Clock Oscillator.....	13
2.8	JTAG.....	14
2.9	Reset Circuit.....	14
3	Measures of Performance	15
3.1	Intrinsic Jitter.....	15
3.2	Jitter Tolerance.....	15
3.3	Jitter Transfer.....	15
3.4	Frequency Accuracy.....	15
3.5	Holdover Accuracy.....	15
3.6	Capture Range.....	15
3.7	Lock Range.....	15
3.8	Phase Slope.....	15
3.9	Time Interval Error (TIE).....	15
3.10	Maximum Time Interval Error (MTIE).....	15
3.11	Phase Continuity.....	16
3.12	Phase Lock Time.....	16
4	Absolute Maximum Ratings	17
5	Recommended DC Operating Conditions	17
6	DC Electrical Characteristics	17
6.1	Single End Input/Output Port.....	17
6.2	Differential Output Port (LVDS).....	18
7	AC Electrical Characteristics	19
7.1	Performance.....	19
7.2	Intrinsic Jitter Unfiltered.....	20
7.3	C1.5o (1.544 MHz) Intrinsic Jitter Filtered.....	20
7.4	C2o (2.048 MHz) Intrinsic Jitter Filtered.....	20
7.5	C19o (19.44 MHz) Intrinsic Jitter Filtered.....	20
7.6	8 kHz Input to 8 kHz Output Jitter Transfer.....	21
7.7	1.544 MHz Input to 1.544 MHz Output Jitter Transfer.....	21
7.8	2.048 MHz Input to 2.048 MHz Output Jitter Transfer.....	21
7.9	19.44 MHz Input to 19.44 MHz Output Jitter Transfer.....	22
7.10	8 kHz Input Jitter Tolerance.....	22

7.11	1.544 MHz Input Jitter Tolerance	22
7.12	2.048 MHz Input Jitter Tolerance	23
7.13	19.44 MHz Input Jitter Tolerance	23
8	Timing Characteristics	25
8.1	Timing Parameter Measurement Voltage Levels	25
8.2	Input/Output Timing	25
9	Ordering Information	30

LIST OF FIGURES

Figure - 1	IDT82V3011 SSOP56 Package Pin Assignment	2
Figure - 2	State Control Circuit	9
Figure - 3	State Control Diagram	9
Figure - 4	TIE Control Block Diagram	11
Figure - 5	Reference Switch with TIE Control Block Enabled	11
Figure - 6	Reference Switch with TIE Control Block Disabled	12
Figure - 7	DPLL Block Diagram	12
Figure - 8	Clock Oscillator Circuit	14
Figure - 9	Power-Up Reset Circuit	14
Figure - 10	Timing Parameter Measurement Voltage Levels	25
Figure - 11	Input to Output Timing (Normal Mode)	27
Figure - 12	Output Timing 1	28
Figure - 13	Output Timing 2	29
Figure - 14	Input Control Setup and Hold Timing	29

LIST OF TABLES

Table - 1	Operating Modes Selection	9
Table - 2	Input Frequency Selection.....	10
Table - 3	C2/C1.5 Output Frequency Control.....	13

1 PIN DESCRIPTION

Name	Type	Pin Number	Description
V _{SS}	Power	12, 18, 27 38, 47	Ground. 0 V. All V _{SS} pins should be connected to the ground.
V _{DD}	Power	13, 19, 26 37, 48	Positive Supply Voltage. All V _{DD} pins should be connected to +3.3 V (nominal).
OSCi	(CMOS) I	50	Oscillator Master Clock Input. This pin is connected to a clock source.
Fref	I	5	Reference Input. This is the input reference source (falling edge of 8 kHz, 1.544 MHz and 2.048 MHz or rising edge of 19.44 MHz) used for synchronization. The frequency of the input reference can be 8 kHz, 1.544 MHz, 2.048 MHz or 19.44 MHz. This pin is internally pulled up to V _{DD} .
F_sel0 F_sel1	I	9 10	Frequency Selection Inputs. These two inputs select one of the four possible frequencies (8 kHz, 1.544 MHz, 2.048 MHz or 19.44 MHz) for the Reference Input (Fref). See Table - 2 for details.
MODE_sel0 MODE_sel1	I	1 2	Mode Selection Inputs. These two inputs determine the operating mode of the IDT82V3011 (Normal, Holdover or Freerun). See Table - 1 for details. The logic levels on these two pins are gated in by the rising edges of F8o. These two pins are internally pulled down to V _{SS} .
RST	I	4	Reset Input. Pulling this pin to logic low for at least 300 ns will reset the IDT82V3011. While the RST pin is low, all framing and clock outputs are at logic high. To ensure proper operation, the device must be reset after it is powered up.
TCLR	I	3	TIE Control Block Reset. Pulling this pin to logic low for at least 300 ns will reset the TIE (Maximum Time Interval Error) control block and result in a realignment of the output phase with the input phase. This pin is internally pulled up to V _{DD} .
TIE_en	I	56	TIE Control Block Enable. A logic high at this pin enables the TIE control block while a logic low disables it. The logic level on this pin is gated in by the rising edges of F8o. This pin is internally pulled down to V _{SS} .
FLOCK	I	45	Fast Lock Mode Enable. If this pin is set to logic high, the DPLL will quickly lock to the input reference within 500 ms.
LOCK	(CMOS) O	44	Lock Indicator. This output pin will go high when the DPLL is frequency locked to the input reference.
HOLDOVER	(CMOS) O	52	Holdover Indicator. This output pin will go high whenever the DPLL enters Holdover mode.
NORMAL	(CMOS) O	46	Normal Indicator. This output pin will go high whenever the DPLL enters Normal mode.
FREERUN	(CMOS) O	51	Freerun Indicator. This output pin will go high whenever the DPLL enters Freerun mode.
MON_out	O	7	Frequency Out-of-range Indicator. A logic high at this pin indicates that the reference input (Fref) is off the nominal frequency by more than ±12 ppm.
C19POS C19NEG	(LVDS) O	21 22	19.44 MHz Clock Output (LVDS Level). This pair of outputs is used for OC3/STS3 applications.
C19o	(CMOS) O	43	19.44 MHz Clock Output (CMOS Level). This output is used for OC3/STS3 applications.
C32o	(CMOS) O	25	32.768 MHz Clock Output. This output is a 32.768 MHz clock used for ST-BUS operation.
C16o	(CMOS) O	24	16.384 MHz Clock Output. This output is a 16.384 MHz clock used for ST-BUS operation.
C8o	(CMOS) O	23	8.192 MHz Clock Output. This output is an 8.192 MHz clock used for ST-BUS operation.
C4o	(CMOS) O	20	4.096 MHz Clock Output. This output is a 4.096 MHz clock used for ST-BUS operation.
C2o	(CMOS) O	17	2.048 MHz Clock Output. This output is a 2.048 MHz clock used for ST-BUS operation.

Name	Type	Pin Number	Description
$\overline{C3o}$	(CMOS) O	16	3.088 MHz Clock Output. This output is used for T1 applications.
C1.5o	(CMOS) O	15	1.544 MHz Clock Output. This output is used for T1 applications.
C6o	(CMOS) O	14	6.312 MHz Clock Output. This output is used for DS2 applications.
C2/C1.5	(CMOS) O	54	2.048 MHz or 1.544 MHz Clock Output. This output can be 2.048 MHz or 1.544 MHz, depending on the frequency selection pins F_sel0 and F_sel1. If the input reference is 8 kHz, 2.048 MHz, or 19.44 MHz, the C2/C1.5 pin will output a 2.048 MHz clock signal. If the input reference is 1.544 MHz, the C2/C1.5 will output a 1.544 MHz clock signal. Refer to Table - 3 for details.
F19o	(CMOS) O	49	8 kHz Frame Signal with 19.44 MHz Pulse Width. This output is used for OC3/STS3 applications.
$\overline{F32o}$	(CMOS) O	40	Frame Pulse ST-BUS 8.192 Mb/s. This is an 8 kHz 30 ns active low framing pulse, which marks the beginning of an ST-BUS frame. This framing signal is typically used for ST-BUS operation at 8.192 Mb/s.
$\overline{F16o}$	(CMOS) O	39	Frame Pulse ST-BUS 8.192 Mb/s. This is an 8 kHz 61 ns active low framing pulse, which marks the beginning of an ST-BUS frame. This framing signal is typically used for ST-BUS operation at 8.192 Mb/s.
F8o	(CMOS) O	36	Frame Pulse. This is an 8 kHz 122 ns active high framing pulse, which marks the beginning of a frame.
$\overline{F0o}$	(CMOS) O	33	Frame Pulse ST-BUS 2.048 Mb/s. This is an 8 kHz 244 ns active low framing pulse, which marks the beginning of an ST-BUS frame. This framing signal is typically used for ST-BUS operation at 2.048 Mb/s and 4.096 Mb/s.
RSP	(CMOS) O	41	Receive Sync Pulse. This is an 8 kHz 488 ns active high framing pulse, which marks the beginning of a ST-BUS frame. This framing signal is typically used to connect to the Siemens MUNICH-32 device.
TSP	(CMOS) O	42	Transmit Sync Pulse. This is an 8 kHz 488 ns active high framing pulse, which marks the beginning of an ST-BUS frame. This framing is typically used to connect to the Siemens MUNICH-32 device.
TDO	(CMOS) O	29	Test Serial Data Out. JTAG serial data is output on this pin on the falling edge of TCK. This pin is held in high impedance state when JTAG scan is not enabled.
TDI	I	32	Test Serial Data In. JTAG serial test instructions and data are shifted in on this pin. This pin is internally pulled up to V_{DD} .
\overline{TRST}	I	30	Test Reset. Asynchronously initializes the JTAG TAP controller by putting it in the Test-Logic-Reset state. This pin is internally pulled up to V_{DD} . It is connected to the ground for normal applications.
TCK	I	28	Test Clock. Provides the clock for the JTAG test logic.
TMS	I	31	Test Mode Select. JTAG signal that controls the state transitions of the TAP controller. This pin is internally pulled up to V_{DD} .
IC0, IC2	-	53, 55	These pins should be connected to V_{SS} .
IC	-	6, 8, 11 34, 35	These pins should be left open.

2 FUNCTIONAL DESCRIPTION

The IDT82V3011 is a T1/E1/OC3 WAN PLL with single reference input, providing timing (clock) and synchronization (framing) signals to interface circuits for multitrunk T1/E1 and STS3/OC3 links. The details are described in the following sections.

2.1 STATE CONTROL CIRCUIT

The State Control Circuit is an important part in the IDT82V3011. It is used to control the TIE block and the DPLL block as shown in Figure - 2. The control is based on the result of Invalid Input Signal Detection and the logic levels on the MODE_sel0, MODE_sel1 and TIE_en pins.

The IDT82V3011 can be operated in three different modes: Normal, Holdover and Freerun. The operating mode is selected by the MODE_sel1 and MODE_sel0 pins, as shown in Table - 1.

Figure - 3 shows the state control diagram. All state changes occur synchronously on the rising edge of F8o. Three operating modes, Normal (S1), Holdover (S3) and Freerun (S0) can be switched from one to another by changing the logic levels on the MODE_sel0 and MODE_sel1 pins.

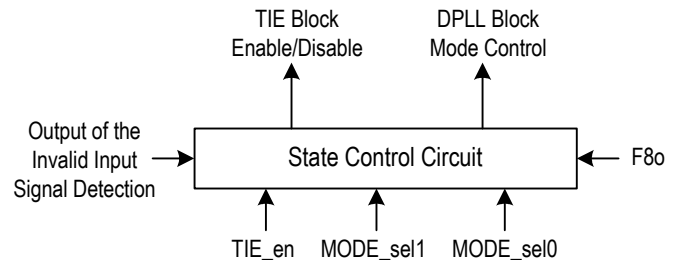
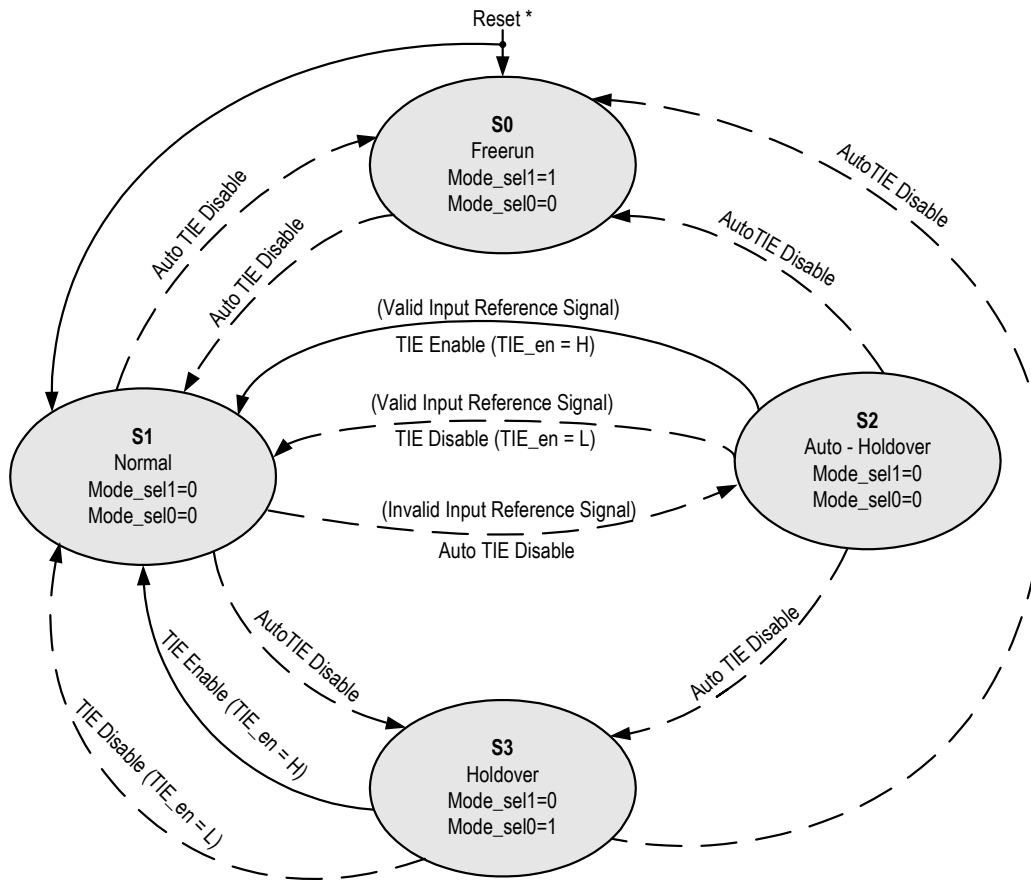

Figure - 2 State Control Circuit

Table - 1 Operating Modes Selection

Mode Selection Pins		Operating Mode
MODE_sel1	MODE_sel0	
0	0	Normal
0	1	Holdover
1	0	Freerun
1	1	Reserved



* Note: After reset, the Mode_sel1 and Mode_sel0 should be initially set to '10' or '00'.

Figure - 3 State Control Diagram

The mode changes between Normal (S1) and Auto-Holdover (S2) are triggered by the Invalid Input Reference Detection Circuit and are irrelative to the logic levels on the MODE_sel0 and MODE_sel1 pins. At the stage of S1, if the input reference is invalid (out of the capture range), the operating mode will be changed to Auto-Holdover (S2) automatically. When the input reference becomes valid, the operating mode will be changed back to Normal (S1) automatically. Refer to “2.4 Invalid Input Signal Detection” for more information.

When changing the operating mode, the TIE control block is enabled/disabled automatically by the state control circuit as shown in Figure - 3, except for the changes from Normal (S1) to Auto-Holdover (S2), and from Auto-Holdover (S2) and Holdover (S3) to Normal (S1). During these three changes, the TIE control block can be enabled or disabled, depending on the logic level on the TIE_en pin.

2.1.1 NORMAL MODE

The Normal mode is typically used when a slave clock source synchronized to the network is required.

In this mode, the IDT82V3011 provides timing ($C1.5o$, $\overline{C3o}$, $C2o$, $\overline{C4o}$, $C8o$, $\overline{C16o}$, $C19o$, $\overline{C32o}$) and synchronization ($\overline{F0o}$, $F8o$, $\overline{F16o}$, $F19o$, $\overline{F32o}$, TSP, RSP) signals. All these signals are synchronous to the input reference. The nominal frequency of the input reference can be 8 kHz, 1.544 MHz, 2.048 MHz or 19.44 MHz.

After reset, the IDT82V3011 will take 30 seconds at most to make the output signals synchronous (phase locked) to the input reference.

Whenever the IDT82V3011 works in the Normal mode, the NORMAL pin will be set to logic high.

2.1.2 FAST LOCK MODE

The Fast Lock mode is a submode of the Normal mode. It allows the DPLL to lock to a reference more quickly than the Normal mode allows. Typically, the locking time in the Fast Lock mode is less than 500 ms.

When the FLOCK pin is set to high, the Fast Lock mode will be enabled.

2.1.3 HOLDOVER MODE

The Holdover mode is typically used for short duration (e.g., 2 seconds) while network synchronization is temporarily disrupted.

In the Holdover mode, the IDT82V3011 provides timing and synchronization signals that are not locked to an external reference signal, but are based on storage techniques. In the Normal mode, when the output frequency is locked to the input reference signal, a numerical value corresponding to the output frequency is stored alternately in two memory locations every 30 ms. When the device is changed to the Holdover mode, the stored value from between 30 ms and 60 ms is used to set the output frequency of the device.

The frequency accuracy in the Holdover mode is ± 0.00625 ppm, which corresponds to a worst case of 18 frame (125 μ s per frame) slips in 24 hours. This meets the AT&T TR62411 requirement of ± 0.37 ppm (255 frame slips per 24 hours).

Whenever the IDT82V3011 works in the Holdover mode, the HOLDOVER pin will be set to logic high.

2.1.4 FREERUN MODE

The Freerun mode is typically used when a master clock source is required, or used when a system is just powered up and the network

synchronization has not been achieved.

In this mode, the IDT82V3011 provides timing and synchronization signals which are based on the master clock frequency (OSCi) only, and are not synchronized to the input reference signal.

The accuracy of the output clock is equal to the accuracy of the master clock (OSCi). So if a ± 32 ppm output clock is required, the master clock must also be ± 32 ppm. Refer to “2.7 OSC” for more information.

Whenever the IDT82V3011 works in the Freerun mode, the FREERUN pin will be set to logic high.

2.2 FREQUENCY SELECT CIRCUIT

The input reference can be 8 kHz, 1.544 MHz, 2.048 MHz or 19.44 MHz, as determined by the F_sel1 and F_sel0 pins. See Table - 2 for details.

Every time the frequency is changed, the device must be reset to make the change effective.

Table - 2 Input Frequency Selection

Frequency Selection Pins		Input Frequency
F_sel1	F_sel0	
0	0	19.44 MHz
0	1	8 kHz
1	0	1.544 MHz
1	1	2.048 MHz

2.3 REFERENCE INPUT MONITOR

The Telcordia GR-1244-CORE standard recommends that the DPLL should be able to reject the references that are off the nominal frequency by more than ± 12 ppm. The IDT82V3011 monitors the frequency of the input reference and outputs a signal at MON_out pin to indicate the monitoring result. Whenever the reference frequency is off the nominal frequency by more than ± 12 ppm, the MON_out pin will go high. The signal at MON_out pin is updated every 2 seconds.

2.4 INVALID INPUT SIGNAL DETECTION

This circuit is used to detect if the input reference is out of the capture range. Refer to “3.6 Capture Range” for details. This includes a complete loss of the input reference and a large frequency shift in the input reference.

If the input reference is invalid (out of the capture range), the IDT82V3011 will be automatically changed to the Holdover mode (Auto-Holdover). When the input reference becomes valid, the device will be changed back to the Normal mode and the output signals will be locked to the input reference.

In the Holdover mode, the output signals are based on the output reference signal 30 ms to 60 ms prior to entering the Holdover mode. The amount of phase drift while in holdover can be negligible because the Holdover mode is very accurate (e.g., 0.00625 ppm). Consequently, the phase delay between the input and output after switching back to the Normal mode is preserved.

2.5 TIE CONTROL BLOCK

If the input reference is badly damaged or lost, it is necessary to use the reference generated by storage techniques instead. But when changing the operating mode, a step change in phase on the input reference will occur. A step change in phase in the DPLL input may lead

to an unacceptable phase change on the output signals. The TIE control block, when enabled, prevents a step change in phase on the input reference signal from causing a step change in phase on the output of the DPLL block. Figure - 4 shows the TIE Control Block diagram.

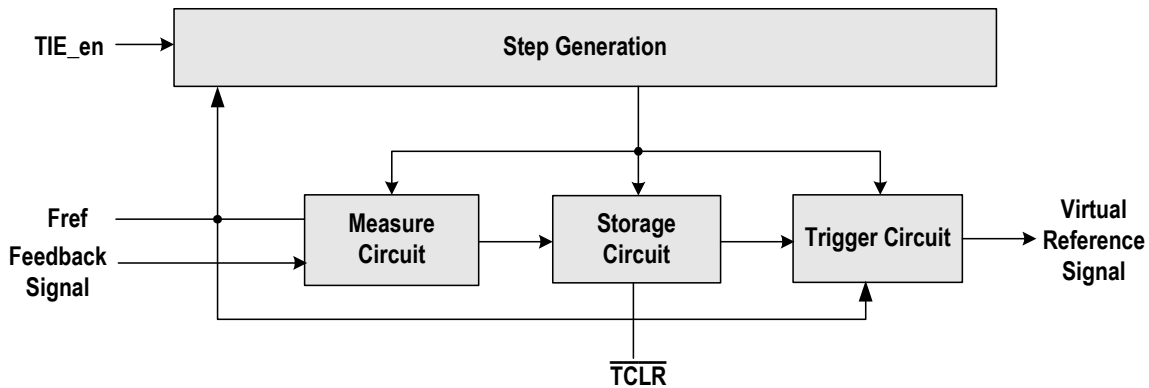

Figure - 4 TIE Control Block Diagram

When the TIE Control Block is enabled manually or automatically (by the TIE_en pin or TIE auto-enable logic generated by the State Control Circuit), it works under the control of the Step Generation circuit.

At the Measure Circuit stage, the input reference signal (Fref) is compared with the feedback signal (current output feed back from the Frequency Select Circuit). The phase difference between the input reference and the feedback signal is stored in the Storage Circuit for TIE correction. According to the value stored in the storage circuit, the Trigger Circuit generates a virtual reference with the same phase as the previous reference. In this way, the reference can be switched without generating a step change in phase.

Figure - 5 shows the phase transient that will result if a mode change

is performed with the TIE Control Block enabled.

The value of the phase difference in the Storage Circuit can be cleared by applying a logic low reset signal to the $\overline{\text{TCLR}}$ pin. The minimum width of the reset pulse should be 300 ns.

When the IDT82V3011 primarily enters the Holdover mode for a short time period and then returns back to the Normal mode, the TIE Control Circuit should not be enabled. This will prevent undesired accumulated phase change between the input and output.

If the TIE Control Block is disabled manually or automatically, a mode change will result in a phase alignment between the input signal and the output signal as shown in Figure - 6. The slope of the phase adjustment is limited to 5 ns per 125 μs .

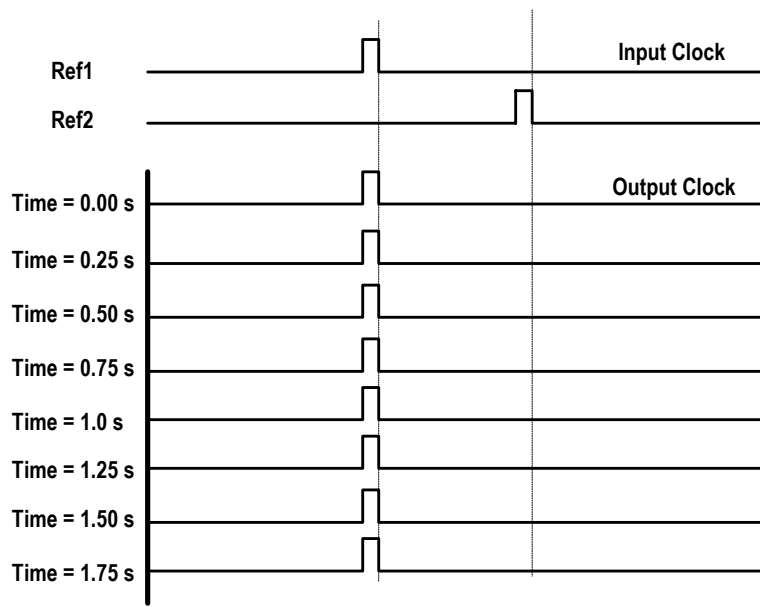

Figure - 5 Reference Switch with TIE Control Block Enabled

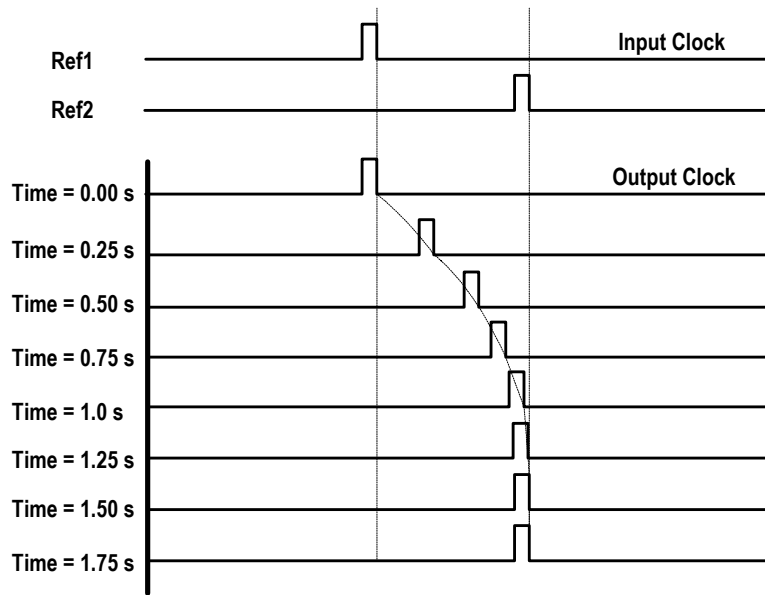

Figure - 6 Reference Switch with TIE Control Block Disabled

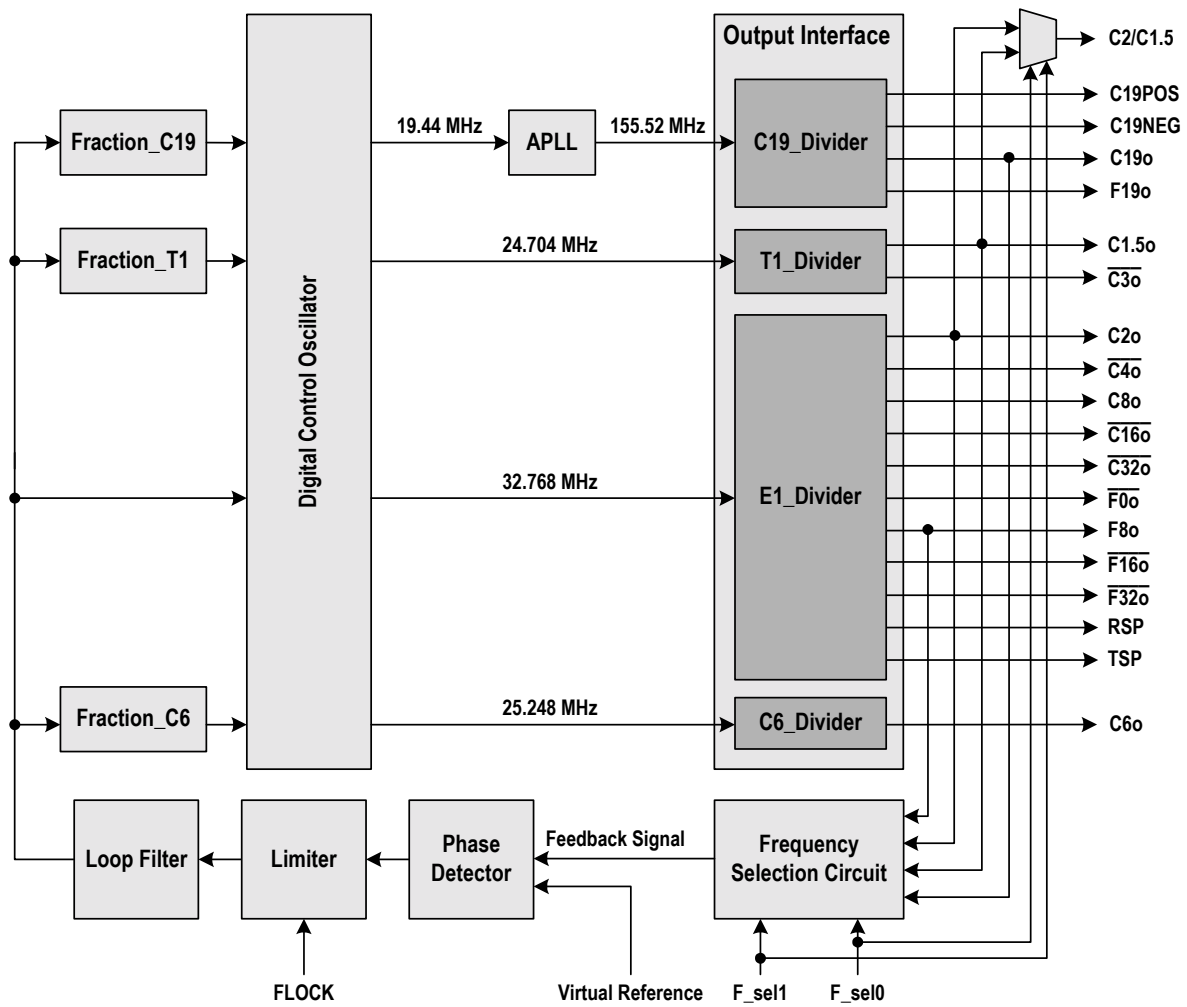

Figure - 7 DPLL Block Diagram

2.6 DPLL BLOCK

As shown in Figure - 7, the DPLL Block consists of a Phase Detector, a Limiter, a Loop Filter, a Digital Control Oscillator and Divider.

2.6.1 PHASE DETECTOR (PHD)

In the Normal mode, the Phase Detector compares the virtual reference signal from the TIE Control Circuit with the feedback signal from the Frequency Select Circuit, and outputs an error signal corresponding to the phase difference. This error signal is sent to the Limiter circuit for phase slope control.

In the Freerun or Holdover mode, the Frequency Select Circuit, the Phase Detector and the Limiter are inactive, and the input reference signal is not used.

2.6.2 LIMITER

The Limiter is used to limit the phase slope. It ensures that the maximum output phase slope is limited to 5 ns per 125 μ s for all input transient conditions. This well meets the AT&T TR62411 and Telcordia GR-1244-CORE specifications, which specify the maximum phase slope of 7.6 ns per 125 μ s and 81 ns per 1.326 ms respectively.

In the Normal mode, the Limiter receives the error signal from the Phase Detector, limits the phase slope within 5 ns per 125 μ s and sends the limited signal to the Loop Filter.

In the Fast Lock mode, the Limiter is disabled, and the DPLL locks to the input reference within 500 ms, which is much shorter than that in the Normal mode.

2.6.3 LOOP FILTER

The Loop Filter ensures that the jitter transfer meets the ETS 300 011 and AT&T TR62411 requirements. It works similarly to a first order low pass filter with 2.1 Hz cutoff frequency for the four valid input frequencies (8 kHz, 1.544 MHz, 2.048 MHz or 19.44 MHz).

The output of the Loop Filter goes to the Digital Control Oscillator directly or through the Fraction blocks, in which E1, T1 C6 and C19 signals are generated.

2.6.4 FRACTION BLOCK

By applying some algorithms to the incoming E1 signal, the Fraction_C19, Fraction_C6 and Fraction_T1 blocks generate C19, C6 and T1 signals respectively.

2.6.5 DIGITAL CONTROL OSCILLATOR (DCO)

In the Normal mode, the DCO receives four limited and filtered signals from Loop Filter or Fraction blocks. Based on the values of the received signals, the DCO generates four digital outputs: 19.44 MHz, 25.248 MHz, 32.768 MHz and 24.704 MHz for C19, C6, E1 and T1 dividers respectively.

In the Holdover mode, the DCO is running at the same frequency as that generated by storage techniques.

In the Freerun mode, the DCO is running at the same frequency as that of the master clock.

2.6.6 LOCK INDICATOR

If the output frequency of the DPLL is identical to the input frequency, and the input phase offset is small enough so that no slope limiting is exhibited, the LOCK pin will be set high.

2.6.7 OUTPUT INTERFACE

The Output Interface uses three output signals from the DCO to generate totally 9 types of clock signals and 7 types of framing signals. All these output signals are synchronous to F8o.

The 32.768 MHz signal is used by the E1_divider to generate five types of clock signals (C2o, $\overline{C4o}$, C8o, $\overline{C16o}$ and $\overline{C32o}$) with nominal 50% duty cycle and six types of framing signals (F0o, F8o, $\overline{F16o}$, $\overline{F32o}$, RSP and TSP).

The 24.704 MHz signal is used by the T1_divider to generate two types of T1 signals (C1.5o and $\overline{C3o}$) with nominal 50% duty cycle.

The 25.248 MHz signal is used by the C6_divider to generate a C6o signal with nominal 50% duty cycle.

The 19.44 MHz signal is sent to an APLL, which outputs a 155.52 MHz signal. The 155.52 MHz signal is used by the C19_divider to generate 19.44 MHz clock signals (C19o, C19POS, C19NEG) with nominal 50% duty cycle and a framing signal F19o.

Additionally, the IDT82V3011 provides an output clock (C2/C1.5) with the frequency controlled by the frequency selection pins F_sel0 and F_sel1. If the reference input is 8 kHz, 2.048 MHz or 19.44 MHz, the C2/C1.5 pin will output a 2.048 MHz clock signal. If the reference input is 1.544 MHz, the C2/C1.5 pin will output a 1.544 MHz clock signal (see Table - 3 for details). The electrical and timing characteristics of this output (2.048 MHz or 1.544 MHz) is the same as that of C2o or C1.5o.

Table - 3 C2/C1.5 Output Frequency Control

Frequency Selection Pins		Fref Input Frequency	C2/C1.5 Output Frequency
F_sel1	F_sel0		
0	0	19.44 MHz	2.048 MHz
0	1	8 kHz	2.048 MHz
1	0	1.544 MHz	1.544 MHz
1	1	2.048 MHz	2.048 MHz

2.7 OSC

The IDT82V3011 can use a clock as the master timing source. In the Freerun mode, the frequency tolerance of the clock outputs is identical to the frequency tolerance of the source at the OSCi pin. For applications not requiring an accurate Freerun mode, the tolerance of the master timing source may be ± 100 ppm. For applications requiring an accurate Freerun mode, such as AT&T TR62411, the tolerance of the master timing source must be no greater than ± 32 ppm.

The desired capture range should be taken into consideration when determining the accuracy of the master timing source. The sum of the accuracy of the master timing source and the capture range of the IDT82V3011 will always equal 230 ppm. For example, if the master timing source is 100 ppm, the capture range will be 130 ppm.

2.7.1 CLOCK OSCILLATOR

When selecting a Clock Oscillator, numerous parameters must be considered. This includes absolute frequency, frequency change over temperature, output rise and fall times, output levels and duty cycle.

For applications requiring ± 32 ppm clock accuracy, the following clock oscillator module may be used.

FOX F7C-2E3-20.0 MHz
 Frequency: 20 MHz
 Tolerance: 25 ppm 0°C to 70°C
 Rise & Fall Time: 10 ns (0.33 V, 2.97 V, 15 pF)
 Duty Cycle: 40% to 60%

For Stratum 3 application, the clock oscillator should meet the following requirements:

Frequency: 20.0 MHz
 Tolerance: ±4.6 ppm over 20 years life time
 Drift: ±0.04 ppm per day @ constant temperature
 ±0.3 ppm over temperature range of 0°C to 70°C

The output clock should be connected directly (not AC coupled) to the OSCi input of the IDT82V3011, as shown in Figure - 8.

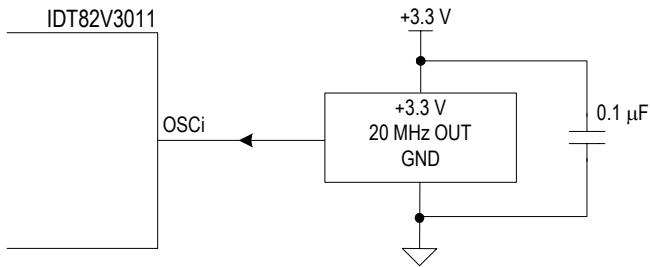

Figure - 8 Clock Oscillator Circuit

2.8 JTAG

The IDT82V3011 supports IEEE 1149.1 JTAG Scan.

2.9 RESET CIRCUIT

A simple power-up reset circuit is shown as Figure - 9. The logic low reset pulse is about 50 μs.

Resistor Rp is used for protection only and limits current into the \overline{RST} pin during power down conditions. The logic low reset pulse width is not critical but should be greater than 300 ns.

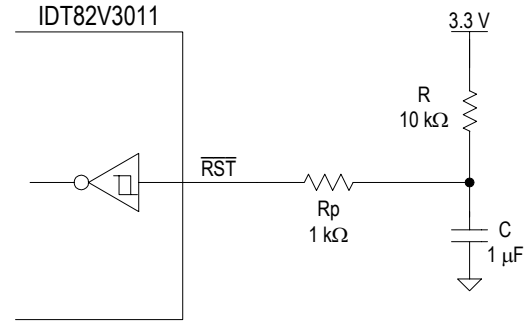

Figure - 9 Power-Up Reset Circuit

3 MEASURES OF PERFORMANCE

The following are some synchronizer performance indicators and their corresponding definitions.

3.1 INTRINSIC JITTER

Intrinsic jitter is the jitter produced by the synchronizing circuit and is measured at its output. It is measured by applying a reference signal with no jitter to the input of the device, and measuring its output jitter. Intrinsic jitter may also be measured when the device is in a non-synchronizing mode, such as free running or holdover, by measuring the output jitter of the device. Intrinsic jitter is usually measured with various band limiting filters depending on the applicable standards. For the IDT82V3011, the intrinsic jitter is limited to less than 0.02 UI on the 2.048 MHz and 1.544 MHz clocks.

3.2 JITTER TOLERANCE

Jitter tolerance is a measure of the ability of a DPLL to operate properly (i.e., remain in lock and or regain lock in the presence of large jitter magnitudes at various jitter frequencies) when jitter is applied to its reference. The applied jitter magnitude and jitter frequency depends on the applicable standards.

3.3 JITTER TRANSFER

Jitter transfer or jitter attenuation refers to the magnitude of jitter at the output of a device for a given amount of jitter at the input of the device. Input jitter is applied at various amplitudes and frequencies, and output jitter is measured with various filters depending on the applicable standards.

For the IDT82V3011, two internal elements determine the jitter attenuation. This includes the internal 2.1 Hz low pass loop filter and the phase slope limiter. The phase slope limiter limits the output phase slope to 5 ns per 125 μ s. Therefore, if the input signal exceeds this rate, such as for very large amplitude, low frequency input jitter, the maximum output phase slope will be limited (i.e., attenuated) to 5 ns per 125 μ s.

The IDT82V3011 has 16 outputs with 4 possible input frequencies for a total of 39 possible jitter transfer functions. Since all outputs are derived from the same signal, the jitter transfer values for the four cases, 8 kHz to 8 kHz, 1.544 MHz to 1.544 MHz, 2.048 MHz to 2.048 MHz and 19.44 MHz to 19.44 MHz can be applied to all outputs.

It should be noted that 1 UI at 1.544 MHz is 644 ns, which is not equal to 1 UI at 2.048 MHz, which is 488 ns. Consequently, a transfer value using different input and output frequencies must be calculated in common units (e.g., seconds).

Using the above method, the jitter attenuation can be calculated for all combinations of inputs and outputs based on the four jitter transfer functions provided. Note that the resulting jitter transfer functions for all combinations of inputs (8 kHz, 1.544 MHz, 2.048 MHz, 19.44 MHz) and outputs (8 kHz, 1.544 MHz, 3.088 MHz, 6.312 MHz, 2.048 MHz, 4.096 MHz, 8.192 MHz, 16.384 MHz, 19.44 MHz, 32.768 MHz) for a given input signal (jitter frequency and jitter amplitude) are the same.

Since intrinsic jitter is always present, jitter attenuation will appear to be lower for small input jitter signals than for large ones. Consequently,

accurate jitter transfer function measurements are usually made with large input jitter signals (e.g., 75% of the specified maximum jitter tolerance).

3.4 FREQUENCY ACCURACY

Frequency accuracy is defined as the absolute tolerance of an output clock signal when it is not locked to an external reference, but is operating in a free running mode. For the IDT82V3011, the Freerun accuracy is equal to the Master Clock (OSCi) accuracy.

3.5 HOLDOVER ACCURACY

Holdover accuracy is defined as the absolute tolerance of an output clock signal, when it is not locked to an external reference signal, but is operating using storage techniques. For the IDT82V3011, the storage value is determined while the device is in Normal mode and locked to an external reference signal.

The absolute Master Clock (OSCi) accuracy of the IDT82V3011 does not affect Holdover accuracy, but the change in OSCi accuracy while in Holdover mode does.

3.6 CAPTURE RANGE

Also referred to as pull-in range. This is the input frequency range over which the synchronizer must be able to pull into synchronization. The IDT82V3011 capture range is equal to ± 230 ppm minus the accuracy of the master clock (OSCi). For example, a 32 ppm master clock results in a capture range of 198 ppm.

The Telcordia GR-1244-CORE standard, recommends that the DPLL should be able to reject references that are off the nominal frequency by more than ± 12 ppm. The IDT82V3011 provides a MON_out pin to indicate whether the reference input Fref is within ± 12 ppm of the nominal frequency.

3.7 LOCK RANGE

This is the input frequency range over which the synchronizer must be able to maintain synchronization. The lock range is equal to the capture range for the IDT82V3011.

3.8 PHASE SLOPE

Phase slope is measured in seconds per second and is the rate at which a given signal changes phase with respect to an ideal signal. The given signal is typically the output signal. The ideal signal is of constant frequency and is nominally equal to the value of the final output signal or final input signal.

3.9 TIME INTERVAL ERROR (TIE)

TIE is the time delay between a given timing signal and an ideal timing signal.

3.10 MAXIMUM TIME INTERVAL ERROR (MTIE)

MTIE is the maximum peak to peak delay between a given timing signal and an ideal timing signal within a particular observation period.

3.11 PHASE CONTINUITY

Phase continuity is the phase difference between a given timing signal and an ideal timing signal at the end of a particular observation period. Usually, the given timing signal and the ideal timing signal are of the same frequency. Phase continuity applies to the output of the synchronizer after a signal disturbance due to a mode change. The observation period is usually the time from the disturbance, to just after the synchronizer has settled to a steady state.

In the case of the IDT82V3011, the output signal phase continuity is maintained to within ± 5 ns at the instance (over one frame) of all mode changes. The total phase shift, depending on the type of mode change, may accumulate up to 200 ns over many frames. The rate of change of the 200 ns phase shift is limited to a maximum phase slope of approximately 5 ns per 125 μ s. This meets the AT&T TR62411 maximum phase slope requirement of 7.6 ns per 125 μ s and Telcordia GR-1244-CORE (81 ns per 1.326 ms).

3.12 PHASE LOCK TIME

This is the time it takes the synchronizer to phase lock to the input

signal. Phase lock occurs when the input signal and output signal are not changing in phase with respect to each other (not including jitter).

Lock time is very difficult to determine because it is affected by many factors including:

1. Initial input to output phase difference
2. Initial input to output frequency difference
3. Synchronizer loop filter
4. Synchronizer limiter

Although a short lock time is desirable, it is not always possible to achieve due to other synchronizer requirements. For instance, better jitter transfer performance is achieved with a lower frequency loop filter which increases lock time. And better (smaller) phase slope performance (limiter) results in longer lock times. The IDT82V3011 loop filter and limiter are optimized to meet the AT&T TR62411 jitter transfer and phase slope requirements. Consequently, phase lock time, which is not a standard requirement, may be longer than in other applications. See ["7.1 Performance"](#) for details.

The IDT82V3011 provides a FLOCK pin to enable the Fast Lock mode. When this pin is set to high, the DPLL will lock to an input reference within approximately 500 ms.

4 ABSOLUTE MAXIMUM RATINGS

Ratings	Min.	Max.	Unit
Power supply voltage	-0.5	5.0	V
Voltage on any pin with respect to ground	-0.5	5.5	V
Package power dissipation		200	mW
Storage temperature	-55	125	°C

Note: Stresses greater than those listed under ABSOLUTE MAXIMUM RATINGS may cause permanent damage to the device. This is a stress rating only and functional operation of the device at these or any other conditions above those indicated in the operational sections of this specification is not implied. Exposure to absolute maximum rating conditions for extended periods may affect reliability.

5 RECOMMENDED DC OPERATING CONDITIONS

Parameter	Min.	Max.	Unit
Operating temperature	-40	+85	°C
Power supply voltage	3.0	3.6	V

6 DC ELECTRICAL CHARACTERISTICS

6.1 SINGLE END INPUT/OUTPUT PORT

Parameter	Description	Min.	Typ.	Max.	Units	Test Conditions *
I_{DDs}	Supply current with OSCi = 0 V			10	mA	Outputs unloaded
I_{DD}	Supply current with OSCi = Clock			60	mA	Outputs unloaded
V_{CIH}	CMOS high-level input voltage	$0.7V_{DD}$			V	OSCi, Fref
V_{CIL}	CMOS low-level input voltage			$0.3V_{DD}$	V	OSCi, Fref
V_{TIH}	TTL high-level input voltage	2.0			V	All input pins except for OSCi and Fref
V_{TIL}	TTL low-level input voltage			0.8	V	All input pins except for OSCi and Fref
I_{IL}	Input leakage current:				μA	$V_I = V_{DD}$ or 0 V
	Normal (low level)	-15		15		
	Normal (high level)	-15		15		
	Pull up (low level)	-100		0		
	Pull up (high level)	-15		15		
	Pull down (low level)	-15		15		
	Pull down (high level)	0		100		
V_{OH}	High-level output voltage	2.4			V	$I_{OH} = 8$ mA
V_{OL}	Low-level output voltage			0.4	V	$I_{OL} = 8$ mA

*** Note:**

1. Voltages are with respect to ground (V_{SS}) unless otherwise stated.
2. Supply voltage and operating temperature are as per Recommended Operating Conditions.

6.2 DIFFERENTIAL OUTPUT PORT (LVDS)

Parameter	Description	Min.	Typ.	Max.	Units	Test Conditions
VOD	Differential Output Voltage	250	350	450	mV	RL = 100 Ω
ΔVOD	Change in Magnitude of VOD for Complementary Output States		4	35	mV	RL = 100 Ω
VOS	Offset Voltage	1.125	1.25	1.375	V	RL = 100 Ω
ΔVOS	Change in Magnitude of VOS for Complementary Output States		5	25	mV	RL = 100 Ω
VOH	Output Voltage High		1.38	1.6	V	RL = 100 Ω
VOL	Output Voltage Low	0.9	1.03		V	RL = 100 Ω
t _{TLH}	Output Rise time		0.38	1.5	ns	RL = 100 Ω
t _{THL}	Output Fall time		0.40	1.5	ns	RL = 100 Ω
IOS	Output Short Circuit Current		6.0	TBD	mA	
IOSD	Differential Output Short Circuit Current		6.0	10	mA	

7 AC ELECTRICAL CHARACTERISTICS

7.1 PERFORMANCE

Description	Min.	Typ.	Max.	Units	Test Conditions / Notes (see "Notes" on page 23)
Freerun Mode accuracy with OSCi at: 0 ppm	-0		+0	ppm	3-7
Freerun Mode accuracy with OSCi at: ± 32 ppm	-32		+32	ppm	3-7
Freerun Mode accuracy with OSCi at: ± 100 ppm	-100		+100	ppm	3-7
Holdover Mode accuracy with OSCi at: 0 ppm	-0.00625		+0.00625	ppm	2, 4-7, 41, 42
Holdover Mode accuracy with OSCi at: ± 32 ppm	-0.00625		+0.00625	ppm	2, 4-7, 41, 42
Holdover Mode accuracy with OSCi at: ± 100 ppm	-0.00625		+0.00625	ppm	2, 4-7, 41, 42
Capture range with OSCi at: 0 ppm	-230		+230	ppm	1, 4-7
Capture range with OSCi at: ± 32 ppm	-198		+198	ppm	1, 4-7
Capture range with OSCi at: ± 100 ppm	-130		+130	ppm	1, 4-7
Phase lock time		50		s	1, 4-13, 43
Output phase continuity with mode switch to Normal			200	ns	2-13
Output phase continuity with mode switch to Freerun			200	ns	1-2, 4-13
Output phase continuity with mode switch to Holdover			50	ns	1, 4-13
Input Frequency accuracy when MON_out is logic low	-12		+12	ppm	
MTIE (maximum time interval error)			600	ns	1-13, 26
Output phase slope			40	$\mu\text{s/s}$	1-13, 26
Reference input for Auto-Holdover with 8 kHz	-18 k		+18 k	ppm	1, 4, 8-10
Reference input for Auto-Holdover with 1.544 MHz	-36 k		+36 k	ppm	1, 5, 8-10
Reference input for Auto-Holdover with 2.048 MHz	-36 k		+36 k	ppm	1, 6, 8-10
Reference input for Auto-Holdover with 19.44 MHz	-36 k		+36 k	ppm	1, 7, 8-10

7.2 INTRINSIC JITTER UNFILTERED

Description	Min.	Typ.	Max.	Units	Test Conditions / Notes (see "Notes" on page 23)
Intrinsic jitter at F8o (8 kHz)			0.0001	U _{Ipp}	1-13, 20-23, 27
Intrinsic jitter at $\overline{F0o}$ (8 kHz)			0.0001	U _{Ipp}	1-13, 20-23, 27
Intrinsic jitter at $\overline{F16o}$ (8 kHz)			0.0001	U _{Ipp}	1-13, 20-23, 27
Intrinsic jitter at C1.5o (1.544 MHz)			0.015	U _{Ipp}	1-13, 20-23, 28
Intrinsic jitter at $\overline{C3o}$ (3.088 MHz)			0.03	U _{Ipp}	1-13, 20-23, 30
Intrinsic jitter at C2o (2.048 MHz)			0.01	U _{Ipp}	1-13, 20-23, 29
Intrinsic jitter at C6o (6.312 MHz)			0.06	U _{Ipp}	1-13, 20-23, 32
Intrinsic jitter at $\overline{C4o}$ (4.096 MHz)			0.02	U _{Ipp}	1-13, 20-23, 31
Intrinsic jitter at C8o (8.192 MHz)			0.04	U _{Ipp}	1-13, 20-23, 33
Intrinsic jitter at $\overline{C16o}$ (16.834 MHz)			0.04	U _{Ipp}	1-13, 20-23, 34
Intrinsic jitter at TSP (8 kHz)			0.0001	U _{Ipp}	1-13, 20-23, 27
Intrinsic jitter at RSP (8 kHz)			0.0001	U _{Ipp}	1-13, 20-23, 27
Intrinsic jitter at $\overline{C32o}$ (32.768 MHz)			0.08	U _{Ipp}	1-13, 20-23, 36

7.3 C1.5o (1.544 MHz) INTRINSIC JITTER FILTERED

Description	Min.	Typ.	Max.	Units	Test Conditions / Notes (see "Notes" on page 23)
Intrinsic jitter (4 Hz to 100 kHz filter)			0.008	U _{Ipp}	1-13, 20-23, 28
Intrinsic jitter (10 Hz to 40 kHz filter)			0.006	U _{Ipp}	1-13, 20-23, 28
Intrinsic jitter (8 kHz to 40 kHz filter)			0.006	U _{Ipp}	1-13, 20-23, 28
Intrinsic jitter (10 Hz to 8 kHz filter)			0.003	U _{Ipp}	1-13, 20-23, 28

7.4 C2o (2.048 MHz) INTRINSIC JITTER FILTERED

Description	Min.	Typ.	Max.	Units	Test Conditions / Notes (see "Notes" on page 23)
Intrinsic jitter (4 Hz to 100 kHz filter)			0.005	U _{Ipp}	1-13, 20-23, 29
Intrinsic jitter (10 Hz to 40 kHz filter)			0.004	U _{Ipp}	1-13, 20-23, 29
Intrinsic jitter (8 kHz to 40 kHz filter)			0.003	U _{Ipp}	1-13, 20-23, 29
Intrinsic jitter (10 Hz to 8 kHz filter)			0.002	U _{Ipp}	1-13, 20-23, 29

7.5 C19o (19.44 MHz) INTRINSIC JITTER FILTERED

Description	Min.	Typ.	Max.	Units	Test Conditions / Notes (see "Notes" on page 23)
Intrinsic jitter (500 Hz to 1.3 MHz filter)			2	ns _p	1-13, 20-23, 35
Intrinsic jitter (65 kHz to 1.3 MHz filter)			0.5	ns _p	1-13, 20-23, 35

7.6 8 KHZ INPUT TO 8 KHZ OUTPUT JITTER TRANSFER

Description	Min.	Typ.	Max.	Units	Test Conditions / Notes (see "Notes" on page 23)
Jitter attenuation for 1 Hz@0.01 Ulpp input	0		6	dB	1, 4, 8-13, 20-21, 23, 27, 37
Jitter attenuation for 1 Hz@0.54 Ulpp input	6		16	dB	1, 4, 8-13, 20-21, 23, 27, 37
Jitter attenuation for 10 Hz@0.10 Ulpp input	15		22	dB	1, 4, 8-13, 20-21, 23, 27, 37
Jitter attenuation for 60 Hz@0.10 Ulpp input	32		38	dB	1, 4, 8-13, 20-21, 23, 27, 37
Jitter attenuation for 300 Hz@0.10 Ulpp input	42			dB	1, 4, 8-13, 20-21, 23, 27, 37
Jitter attenuation for 3600 Hz@0.005 Ulpp input	50			dB	1, 4, 8-13, 20-21, 23, 27, 37

7.7 1.544 MHZ INPUT TO 1.544 MHZ OUTPUT JITTER TRANSFER

Description	Min.	Typ.	Max.	Units	Test Conditions / Notes (see "Notes" on page 23)
Jitter attenuation for 1 Hz@20 Ulpp input	0		6	dB	1, 5, 8-13, 20-21, 23, 28, 37
Jitter attenuation for 1 Hz@104 Ulpp input	6		16	dB	1, 5, 8-13, 20-21, 23, 28, 37
Jitter attenuation for 10 Hz@20 Ulpp input	17		22	dB	1, 5, 8-13, 20-21, 23, 28, 37
Jitter attenuation for 60 Hz@20 Ulpp input	33		38	dB	1, 5, 8-13, 20-21, 23, 28, 37
Jitter attenuation for 300 Hz@20 Ulpp input	45			dB	1, 5, 8-13, 20-21, 23, 28, 37
Jitter attenuation for 10 kHz@0.3 Ulpp input	48			dB	1, 5, 8-13, 20-21, 23, 28, 37
Jitter attenuation for 40 kHz@0.3 Ulpp input	50			dB	1, 5, 8-13, 20-21, 23, 28, 37

7.8 2.048 MHZ INPUT TO 2.048 MHZ OUTPUT JITTER TRANSFER

Description	Min.	Typ.	Max.	Units	Test Conditions / Notes (see "Notes" on page 23)
Jitter at output for 1 Hz@3.00 Ulpp input			2.5	Ulpp	1, 6, 8-13, 20-21, 23, 29, 37
Jitter at output for 1 Hz@3.00 Ulpp input with 40 Hz to 100 kHz filter			0.07	Ulpp	1, 6, 8-13, 20-21, 23, 29, 38
Jitter at output for 3 Hz@2.33 Ulpp input			1.4	Ulpp	1, 6, 8-13, 20-21, 23, 29, 37
Jitter at output for 3 Hz@2.33 Ulpp input with 40 Hz to 100 kHz filter			0.10	Ulpp	1, 6, 8-13, 20-21, 23, 29, 38
Jitter at output for 5 Hz@2.07 Ulpp input			0.90	Ulpp	1, 6, 8-13, 20-21, 23, 29, 37
Jitter at output for 5 Hz@2.07 Ulpp input with 40 Hz to 100 kHz filter			0.10	Ulpp	1, 6, 8-13, 20-21, 23, 29, 38
Jitter at output for 10 Hz@1.76 Ulpp input			0.40	Ulpp	1, 6, 8-13, 20-21, 23, 29, 37
Jitter at output for 10 Hz@1.76 Ulpp input with 40 Hz to 100 kHz filter			0.10	Ulpp	1, 6, 8-13, 20-21, 23, 29, 38
Jitter at output for 100 Hz@1.50 Ulpp input			0.06	Ulpp	1, 6, 8-13, 20-21, 23, 29, 37
Jitter at output for 100 Hz@1.50 Ulpp input with 40 Hz to 100 kHz filter			0.05	Ulpp	1, 6, 8-13, 20-21, 23, 29, 38
Jitter at output for 2400 Hz@1.50 Ulpp input			0.04	Ulpp	1, 6, 8-13, 20-21, 23, 29, 37
Jitter at output for 2400 Hz@1.50 Ulpp input with 40 Hz to 100 kHz filter			0.03	Ulpp	1, 6, 8-13, 20-21, 23, 29, 38
Jitter at output for 100 kHz@0.20 Ulpp input			0.04	Ulpp	1, 6, 8-13, 20-21, 23, 29, 37
Jitter at output for 100 kHz@0.20 Ulpp input with 40 Hz to 100 kHz filter			0.02	Ulpp	1, 6, 8-13, 20-21, 23, 29, 38

7.9 19.44 MHZ INPUT TO 19.44 MHZ OUTPUT JITTER TRANSFER

Description	Min.	Typ.	Max.	Units	Test Conditions / Notes (see "Notes" on page 23)
Jitter attenuation for 1 Hz@20 Ulpp input	0		6	dB	1, 7-13, 20-21, 23, 35, 37
Jitter attenuation for 1 Hz@104 Ulpp input	6		16	dB	1, 7-13, 20-21, 23, 35, 37
Jitter attenuation for 10 Hz@20 Ulpp input	17		22	dB	1, 7-13, 20-21, 23, 35, 37
Jitter attenuation for 60 Hz@20 Ulpp input	33		38	dB	1, 7-13, 20-21, 23, 35, 37
Jitter attenuation for 300 Hz@20 Ulpp input	45			dB	1, 7-13, 20-21, 23, 35, 37
Jitter attenuation for 10 kHz@0.3 Ulpp input	48			dB	1, 7-13, 20-21, 23, 35, 37
Jitter attenuation for 40 kHz@0.3 Ulpp input	50			dB	1, 7-13, 20-21, 23, 35, 37

7.10 8 KHZ INPUT JITTER TOLERANCE

Description	Min.	Typ.	Max.	Units	Test Conditions / Notes (see "Notes" on page 23)
Jitter tolerance for 1 Hz input	0.80			Ulpp	1, 4, 8-13, 20-21, 23-25, 27
Jitter tolerance for 5 Hz input	0.70			Ulpp	1, 4, 8-13, 20-21, 23-25, 27
Jitter tolerance for 20 Hz input	0.60			Ulpp	1, 4, 8-13, 20-21, 23-25, 27
Jitter tolerance for 300 Hz input	0.16			Ulpp	1, 4, 8-13, 20-21, 23-25, 27
Jitter tolerance for 400 Hz input	0.14			Ulpp	1, 4, 8-13, 20-21, 23-25, 27
Jitter tolerance for 700 Hz input	0.07			Ulpp	1, 4, 8-13, 20-21, 23-25, 27
Jitter tolerance for 2400 Hz input	0.02			Ulpp	1, 4, 8-13, 20-21, 23-25, 27
Jitter tolerance for 3600 Hz input	0.01			Ulpp	1, 4, 8-13, 20-21, 23-25, 27

7.11 1.544 MHZ INPUT JITTER TOLERANCE

Description	Min.	Typ.	Max.	Units	Test Conditions / Notes (see "Notes" on page 23)
Jitter tolerance for 1 Hz input	150			Ulpp	1, 5, 8-13, 20-21, 23-25, 28
Jitter tolerance for 5 Hz input	140			Ulpp	1, 5, 8-13, 20-21, 23-25, 28
Jitter tolerance for 20 Hz input	130			Ulpp	1, 5, 8-13, 20-21, 23-25, 28
Jitter tolerance for 300 Hz input	38			Ulpp	1, 5, 8-13, 20-21, 23-25, 28
Jitter tolerance for 400 Hz input	25			Ulpp	1, 5, 8-13, 20-21, 23-25, 28
Jitter tolerance for 700 Hz input	15			Ulpp	1, 5, 8-13, 20-21, 23-25, 28
Jitter tolerance for 2400 Hz input	5			Ulpp	1, 5, 8-13, 20-21, 23-25, 28
Jitter tolerance for 10 kHz input	1.2			Ulpp	1, 5, 8-13, 20-21, 23-25, 28
Jitter tolerance for 40 kHz input	0.5			Ulpp	1, 5, 8-13, 20-21, 23-25, 28

7.12 2.048 MHZ INPUT JITTER TOLERANCE

Description	Min.	Typ.	Max.	Units	Test Conditions / Notes (see "Notes" on page 23)
Jitter tolerance for 1 Hz input	150			U _{Ipp}	1, 6, 8-13, 20-21, 23-25, 29
Jitter tolerance for 5 Hz input	140			U _{Ipp}	1, 6, 8-13, 20-21, 23-25, 29
Jitter tolerance for 20 Hz input	130			U _{Ipp}	1, 6, 8-13, 20-21, 23-25, 29
Jitter tolerance for 300 Hz input	40			U _{Ipp}	1, 6, 8-13, 20-21, 23-25, 29
Jitter tolerance for 400 Hz input	33			U _{Ipp}	1, 6, 8-13, 20-21, 23-25, 29
Jitter tolerance for 700 Hz input	18			U _{Ipp}	1, 6, 8-13, 20-21, 23-25, 29
Jitter tolerance for 2400 Hz input	5.5			U _{Ipp}	1, 6, 8-13, 20-21, 23-25, 29
Jitter tolerance for 10 kHz input	1.3			U _{Ipp}	1, 6, 8-13, 20-21, 23-25, 29
Jitter tolerance for 100 kHz input	0.4			U _{Ipp}	1, 6, 8-13, 20-21, 23-25, 29

7.13 19.44 MHZ INPUT JITTER TOLERANCE

Description	Min.	Typ.	Max.	Units	Test Conditions / Notes (see "Notes" on page 23)
Jitter tolerance for 12 μ Hz input	2800			U _{Ipp}	1, 7-13, 20-21, 23-25, 35
Jitter tolerance for 178 μ Hz input	2800			U _{Ipp}	1, 7-13, 20-21, 23-25, 35
Jitter tolerance for 0.0016 Hz input	311			U _{Ipp}	1, 7-13, 20-21, 23-25, 35
Jitter tolerance for 0.0156 Hz input	311			U _{Ipp}	1, 7-13, 20-21, 23-25, 35
Jitter tolerance for 0.125 Hz input	39			U _{Ipp}	1, 7-13, 20-21, 23-25, 35
Jitter tolerance for 19.3 Hz input	39			U _{Ipp}	1, 7-13, 20-21, 23-25, 35
Jitter tolerance for 500 Hz input	1.5			U _{Ipp}	1, 7-13, 20-21, 23-25, 35
Jitter tolerance for 6.5 kHz input	1.5			U _{Ipp}	1, 7-13, 20-21, 23-25, 35
Jitter tolerance for 65 kHz input	0.15			U _{Ipp}	1, 7-13, 20-21, 23-25, 35
Jitter tolerance for 1.3 MHz input	0.15			U _{Ipp}	1, 7-13, 20-21, 23-25, 35

Notes:

Voltages are with respect to ground (V_{SS}) unless otherwise stated. Supply voltage and operating temperature are as per Recommended Operating Conditions. Timing parameters are as per Timing Parameter Measurement Voltage Levels.

- Normal mode selected.
- Holdover mode selected.
- Freerun mode selected.
- 8 kHz frequency mode selected.
- 1.544 MHz frequency mode selected.
- 2.048 MHz frequency mode selected.
- 19.44 MHz frequency mode selected.
- Master clock input OSCi at 20 MHz \pm 0 ppm.
- Master clock input OSCi at 20 MHz \pm 32 ppm.
- Master clock input OSCi at 20 MHz \pm 100 ppm.
- Reference input at \pm 0 ppm.
- Reference input at \pm 32 ppm.
- Reference input at \pm 100 ppm.
- For Freerun mode of \pm 0 ppm.
- For Freerun mode of \pm 32 ppm.
- For Freerun mode of \pm 100 ppm.
- For capture range of \pm 230 ppm.
- For capture range of \pm 198 ppm.

19. For capture range of ± 130 ppm.
20. 25 pF capacitive load.
21. OSCi Master Clock jitter is less than 2 nspp, or 0.04 Ulpp where 1 Ulpp = 1/20 MHz.
22. Jitter on reference input is less than 7 nspp.
23. Applied jitter is sinusoidal.
24. Minimum applied input jitter magnitude to regain synchronization.
25. Loss of synchronization is obtained at slightly higher input jitter amplitudes.
26. Within 10 ms of the state change.
27. 1 Ulpp = 125 μ s for 8 kHz signals.
28. 1 Ulpp = 648 ns for 1.544 MHz signals.
29. 1 Ulpp = 488 ns for 2.048 MHz signals.
30. 1 Ulpp = 323 ns for 3.088 MHz signals.
31. 1 Ulpp = 244 ns for 4.096 MHz signals.
32. 1 Ulpp = 158 ns for 6.312 MHz signals.
33. 1 Ulpp = 122 ns for 8.192 MHz signals.
34. 1 Ulpp = 61 ns for 16.484 MHz signals.
35. 1 Ulpp = 51 ns for 19.44 MHz signals.
36. 1 Ulpp = 30 ns for 32.968 MHz signals.
37. No filter.
38. 40 Hz to 100 kHz bandpass filter.
39. With respect to reference input signal frequency.
40. After a $\overline{\text{RST}}$ or $\overline{\text{TCLR}}$.
41. Master clock duty 40% to 60%.
42. Prior to Holdover mode, device as in Normal mode and phase locked.
43. With input frequency offset of 100 ppm.

8 TIMING CHARACTERISTICS

8.1 TIMING PARAMETER MEASUREMENT VOLTAGE LEVELS

Parameter	Description	CMOS	Units
V_T	Threshold Voltage	$0.5V_{DD}$	V
V_{HM}	Rise and Fall Threshold Voltage High	$0.7V_{DD}$	V
V_{LM}	Rise and Fall Threshold Voltage Low	$0.3V_{DD}$	V

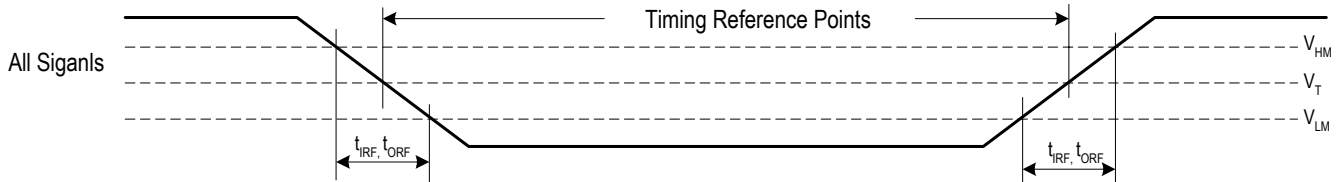

Figure - 10 Timing Parameter Measurement Voltage Levels

Notes:

1. Voltages are with respect to ground (V_{SS}) unless otherwise stated.
2. Supply voltage and operating temperature are as per Recommended Operating Conditions.
3. Timing for input and output signals is based on the worst case result of the CMOS thresholds.

8.2 INPUT/OUTPUT TIMING

Parameter	Description	Min.	Typ.	Max.	Units	Test Conditions
t_{RW}	Reference input pulse width high or low	100			ns	8 kHz, 1.544 MHz or 2.048 MHz reference input
		5			ns	19.44 MHz reference input
t_{IRF}	Reference input rise or fall time			10	ns	
t_{R8D}	8 kHz reference input to F8o delay	0		25	ns	
t_{R15D}	1.544 MHz reference input to F8o delay	326		342	ns	
t_{R2D}	2.048 MHz reference input to F8o delay	248		264	ns	
t_{R19D}	19.44 MHz reference input to F8o delay		5		ns	
t_{FOD}	F8o to $\overline{F0o}$ delay	111		130	ns	
t_{F16S}	$\overline{F16o}$ setup to $\overline{C16o}$ falling	25		40	ns	
t_{F16H}	$\overline{F16o}$ hold to $\overline{C16o}$ falling	25		40	ns	
t_{F19S}	F19o setup to C19o falling		25		ns	
t_{F19H}	F19o hold to C19o falling		25		ns	
t_{C15D}	F8o to C1.5o delay	-10		10	ns	
t_{C3D}	F8o to $\overline{C3o}$ delay	-10		10	ns	
t_{C6D}	F8o to C6o delay	-10		10	ns	
t_{C2D}	F8o to C2o	-11		5	ns	
t_{C4D}	F8o to $\overline{C4o}$	-11		5	ns	
t_{C8D}	F8o to C8o delay	-11		5	ns	
t_{C16D}	F8o to $\overline{C16o}$ delay	-11		5	ns	

Parameter	Description	Min.	Typ.	Max.	Units	Test Conditions
t_{C19D}	F8o to C19o delay	-11		5	ns	
t_{C32D}	F8o to $\overline{C32o}$ delay	-11		5	ns	
t_{TSPD}	F8o to TSP delay	-6		10	ns	
t_{RSPD}	F8o to RSP delay	-8		8	ns	
t_{C15W}	C1.5o pulse width high or low	309		339	ns	
t_{C3W}	$\overline{C3o}$ pulse width high or low	154		169	ns	
t_{C6W}	C6o pulse width high or low	70		86	ns	
t_{C2W}	C2o pulse width high or low	232		258	ns	
t_{C4W}	$\overline{C4o}$ pulse width high or low	111		133	ns	
t_{C8W}	C8o pulse width high or low	52		70	ns	
t_{C16W}	$\overline{C16o}$ pulse width high or low	24		35	ns	
t_{C19W}	C19o pulse width high or low		25		ns	
t_{C32W}	$\overline{C32o}$ pulse width high or low	14		16.78	ns	
t_{TSPW}	TSP pulse width high	478		494	ns	
t_{RSPW}	RSP pulse width high	474		491	ns	
t_{F0WL}	$\overline{F0o}$ pulse width low	234		254	ns	
t_{F8WH}	F8o pulse width high	109		135	ns	
t_{F16WL}	$\overline{F16o}$ pulse width low	47		72	ns	
t_{F19WH}	F19o pulse width low		25		ns	
t_{ORF}	Output clock and frame pulse rise or fall time			9	ns	
t_S	Input controls setup Time	100			ns	
t_H	Input controls hold Time	100			ns	
t_{F16D}	F8o to $\overline{F16o}$ delay	24		38	ns	
t_{F19D}	F8o to F19o delay		25		ns	
t_{F32D}	F8o to $\overline{F32o}$ delay	12		19	ns	
t_{F32S}	$\overline{F32o}$ setup to $\overline{C32o}$ falling	11			ns	
t_{F32H}	$\overline{F32o}$ hold to $\overline{C32o}$ falling	11			ns	
t_{F32WL}	$\overline{F32o}$ pulse width low	15		31	ns	

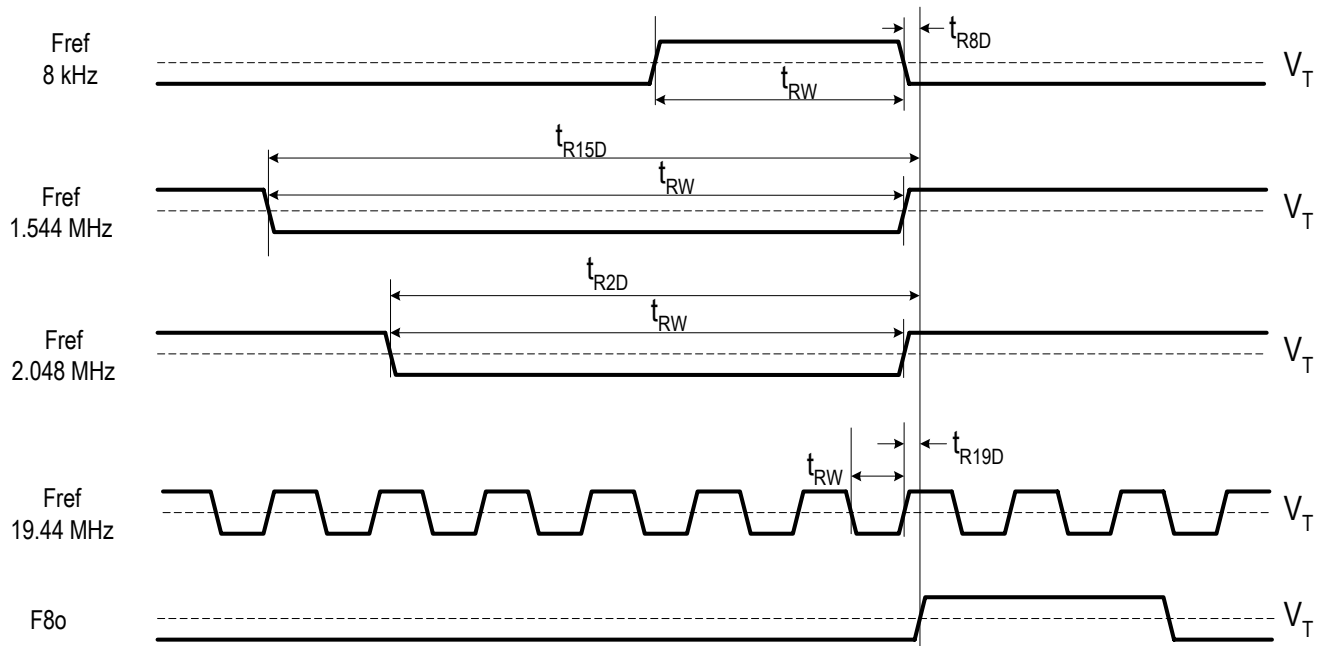

Figure - 11 Input to Output Timing (Normal Mode)

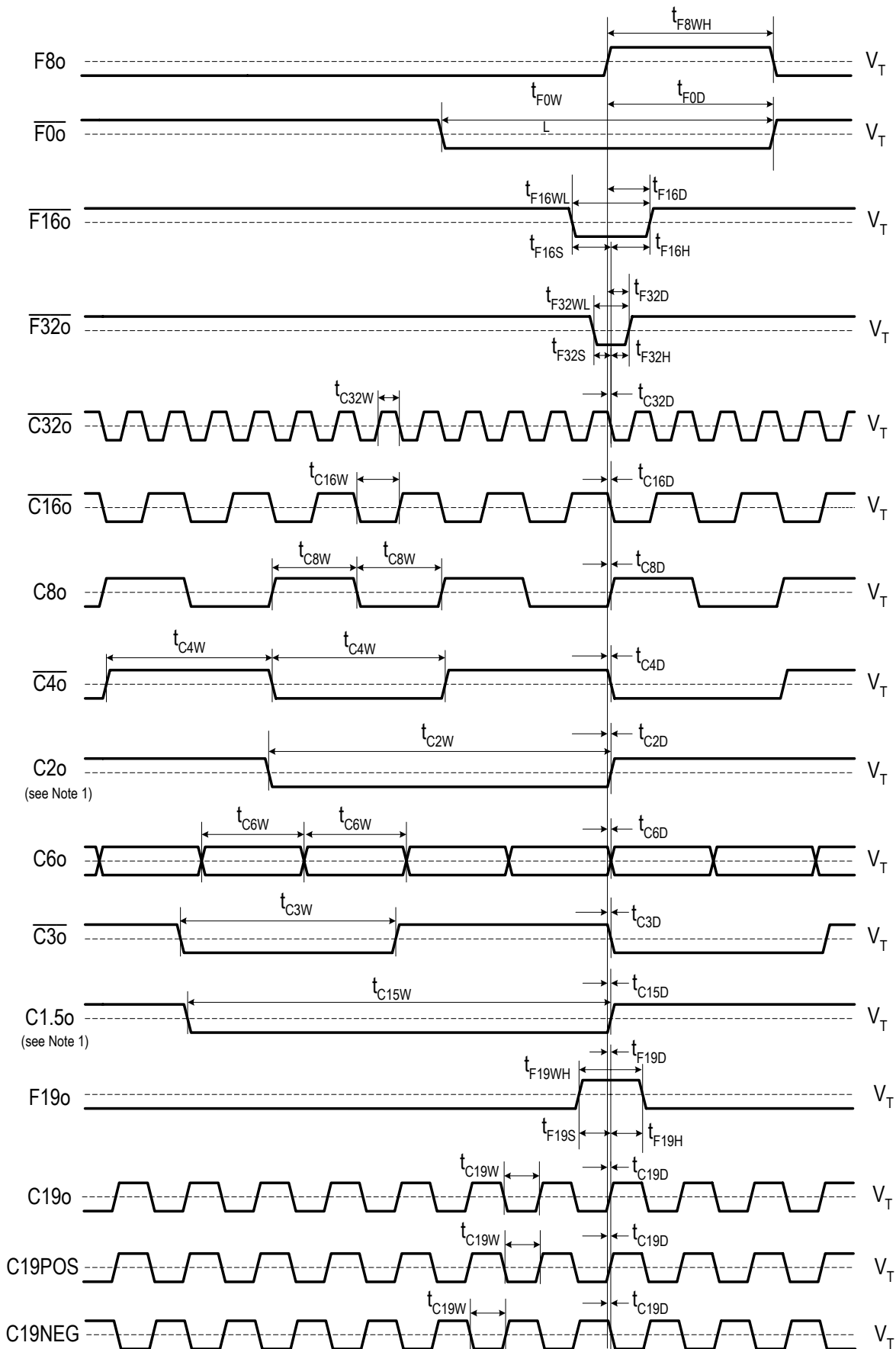

Figure - 12 Output Timing 1

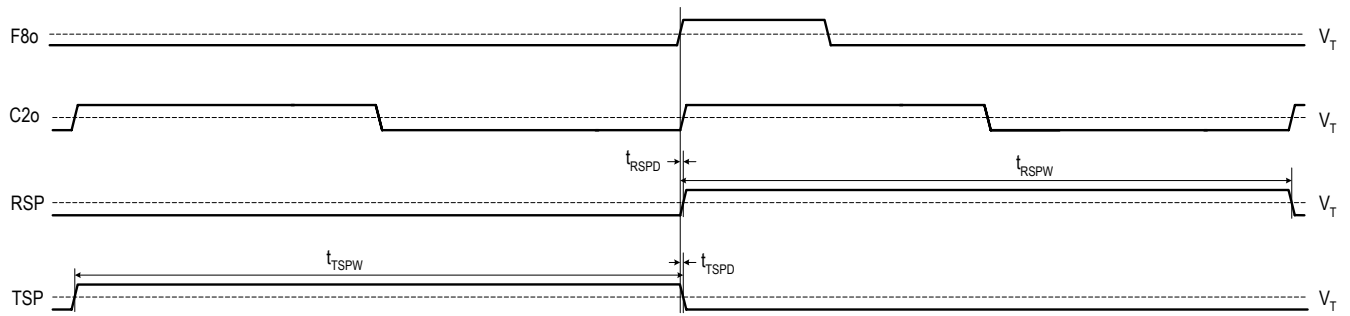

Figure - 13 Output Timing 2

Note 1: The timing characteristic of C2/C1.5 (2.048 MHz or 1.544 MHz) is as same as that of C2o or C1.5o.

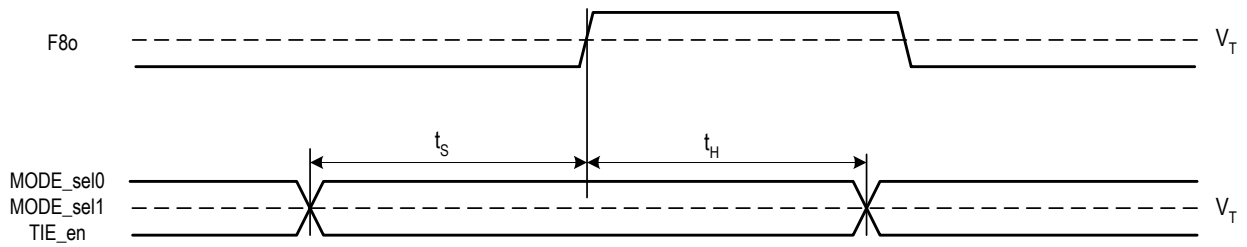
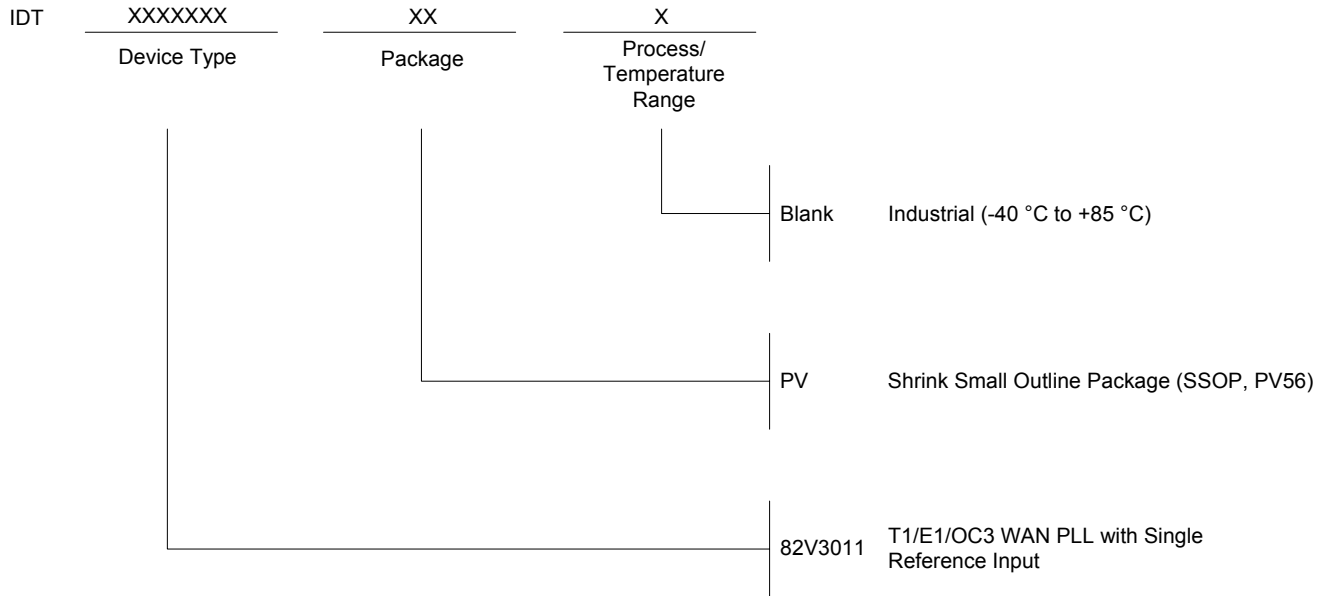

Figure - 14 Input Control Setup and Hold Timing

9 ORDERING INFORMATION



DATASHEET DOCUMENT HISTORY

07/21/2003 pgs. 7, 8, 17.



CORPORATE HEADQUARTERS
2975 Stender Way
Santa Clara, CA 95054

for SALES:
800-345-7015 or 408-727-6116
fax: 408-492-8674
www.idt.com

for Tech Support:
email: telecomhelp@idt.com
phone: 408-330-1753