

TOSHIBA TRANSISTOR SILICON NPN EPITAXIAL TYPE (PCT PROCESS)

RN1901, RN1902, RN1903, RN1904, RN1905, RN1906

SWITCHING, INVERTER CIRCUIT, INTERFACE CIRCUIT
AND DRIVER CIRCUIT APPLICATIONS.

Unit in mm

- Including Two Devices in US6 (Ultra Super Mini Type with 6 leads)
- With Built-in Bias Resistors
- Simplify Circuit Design
- Reduce a Quantity of Parts and Manufacturing Process
- Complementary to RN2901~RN2906

EQUIVALENT CIRCUIT AND BIAS RESISTOR VALUES

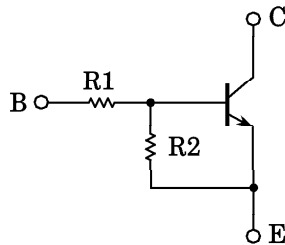

TYPE No.	R1 (kΩ)	R2 (kΩ)
RN1901	4.7	4.7
RN1902	10	10
RN1903	22	22
RN1904	47	47
RN1905	2.2	47
RN1906	4.7	47

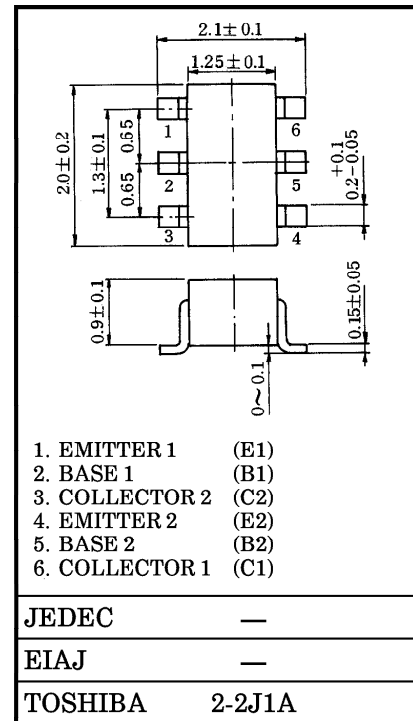

Weight : 6.8mg

EQUIVALENT CIRCUIT (TOP VIEW)

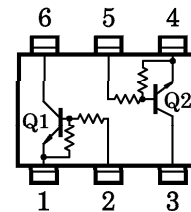

MAXIMUM RATINGS (Ta = 25°C) (Q1, Q2 COMMON)

CHARACTERISTIC		SYMBOL	RATING	UNIT
Collector-Base Voltage	RN1901~1906	V _{CB0}	50	V
Collector-Emitter Voltage		V _{CE0}	50	V
Emitter-Base Voltage	RN1901~1904	V _{EB0}	10	V
	RN1905, 1906		5	
Collector Current	RN1901~1906	I _C	100	mA
Collector Power Dissipation		P _C *	200	mW
Junction Temperature		T _j	150	°C
Storage Temperature Range		T _{stg}	-55~150	°C

* : Total Rating

961001EAA2

● TOSHIBA is continually working to improve the quality and the reliability of its products. Nevertheless, semiconductor devices in general can malfunction or fail due to their inherent electrical sensitivity and vulnerability to physical stress. It is the responsibility of the buyer, when utilizing TOSHIBA products, to observe standards of safety, and to avoid situations in which a malfunction or failure of a TOSHIBA product could cause loss of human life, bodily injury or damage to property. In developing your designs, please ensure that TOSHIBA products are used within specified operating ranges as set forth in the most recent products specifications. Also, please keep in mind the precautions and conditions set forth in the TOSHIBA Semiconductor Reliability Handbook.

ELECTRICAL CHARACTERISTICS (Ta = 25°C) (Q1, Q2 COMMON)

CHARACTERISTIC		SYMBOL	TEST CONDITION	MIN.	TYP.	MAX.	UNIT
Collector Cut-off Current	RN1901~1906	ICBO	V _{CB} = 50V, I _E = 0	—	—	100	nA
		ICEO	V _{CE} = 50V, I _B = 0	—	—	500	
Emitter Cut-off Current	RN1901	I _{EBO}	V _{EB} = 10V, I _C = 0	0.82	—	1.52	mA
	RN1902			0.38	—	0.71	
	RN1903			0.17	—	0.33	
	RN1904		V _{EB} = 5V, I _C = 0	0.082	—	0.15	
	RN1905			0.078	—	0.145	
	RN1906			0.074	—	0.138	
DC Current Gain	RN1901	h _{FE}	V _{CE} = 5V, I _C = 10mA	30	—	—	
	RN1902			50	—	—	
	RN1903			70	—	—	
	RN1904			80	—	—	
	RN1905			80	—	—	
	RN1906			80	—	—	
Collector-Emitter Saturation Voltage	RN1901~1906	V _{CE (sat)}	I _C = 5mA I _B = 0.25mA	—	0.1	0.3	V
Input Voltage (ON)	RN1901	V _{I (ON)}	V _{CE} = 0.2V I _C = 5mA	1.1	—	2.0	V
	RN1902			1.2	—	2.4	
	RN1903			1.3	—	3.0	
	RN1904			1.5	—	5.0	
	RN1905			0.6	—	1.1	
	RN1906			0.7	—	1.3	
Input Voltage (OFF)	RN1901~1904	V _{I (OFF)}	V _{CE} = 5V I _C = 0.1mA	1.0	—	1.5	V
	RN1905, 1906			0.5	—	0.8	
Transition Frequency	RN1901~1906	f _T	V _{CE} = 10V, I _C = 5mA	—	250	—	MHz
Collector Output Capacitance	RN1901~1906	C _{ob}	V _{CB} = 10V, I _E = 0, f = 1MHz	—	3	6	pF
Input Resistor	RN1901	R1		3.29	4.7	6.11	kΩ
	RN1902			7	10	13	
	RN1903			15.4	22	28.6	
	RN1904			32.9	47	61.1	
	RN1905			1.54	2.2	2.86	
	RN1905			3.29	4.7	6.11	
Resistor Ratio	RN1901~1904	R1 / R2		0.9	1.0	1.1	
	RN1905			0.0421	0.0468	0.0515	
	RN1906			0.09	0.1	0.11	

961001EAA2'

- The information contained herein is presented only as a guide for the applications of our products. No responsibility is assumed by TOSHIBA CORPORATION for any infringements of intellectual property or other rights of the third parties which may result from its use. No license is granted by implication or otherwise under any intellectual property or other rights of TOSHIBA CORPORATION or others.
- The information contained herein is subject to change without notice.

(Q1, Q2 COMMON)

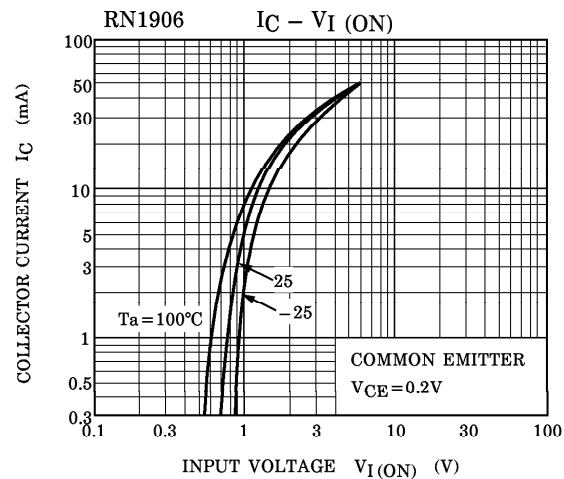
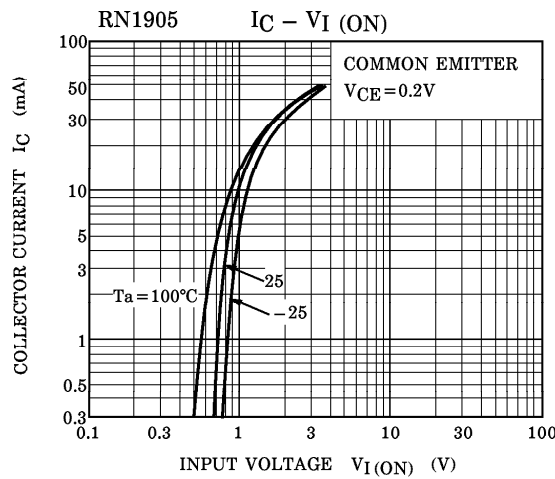
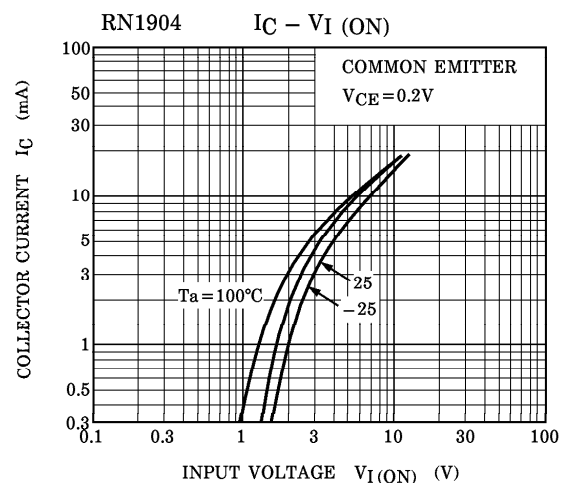
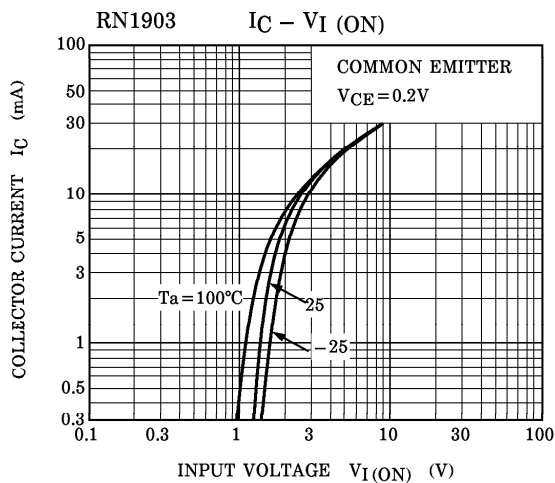
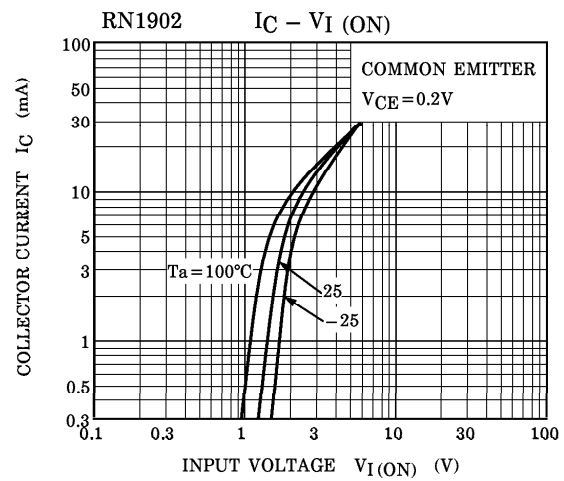
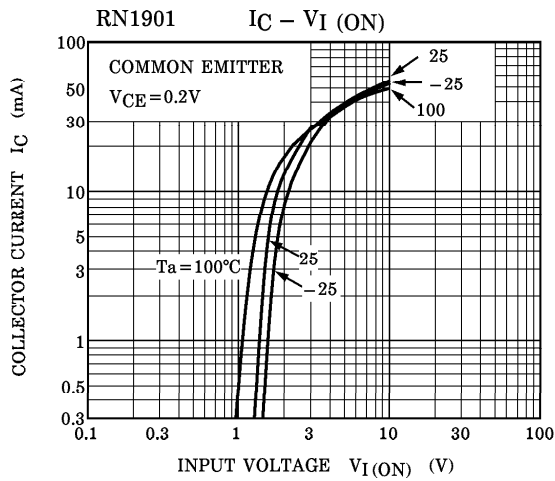

(Q1, Q2 COMMON)

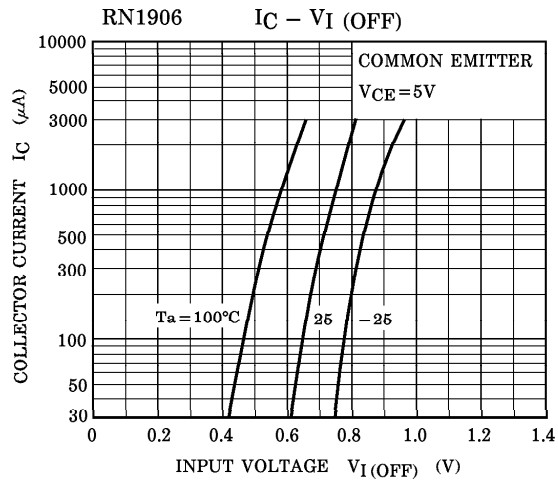
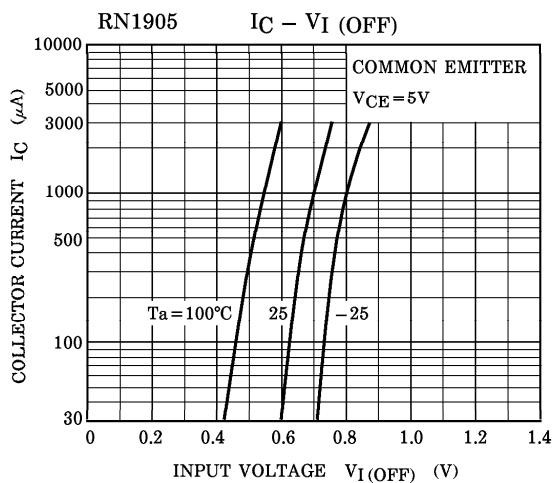
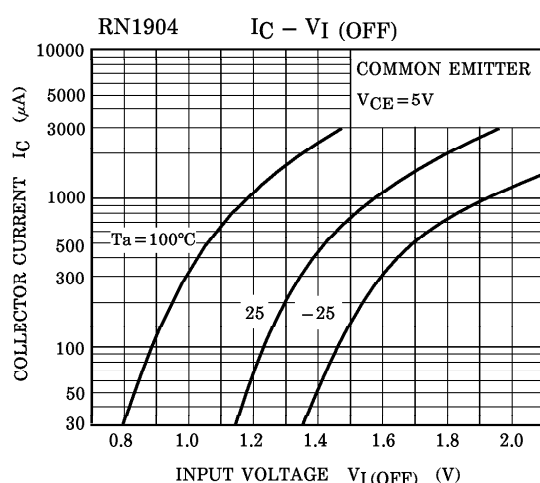
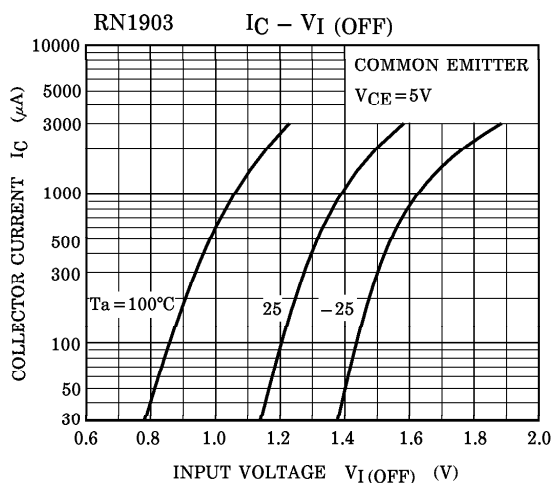
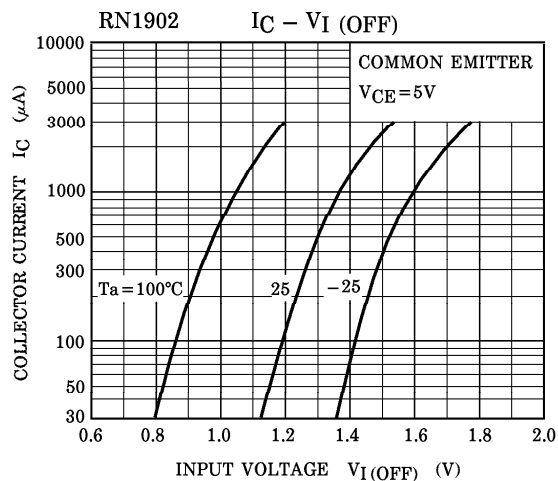
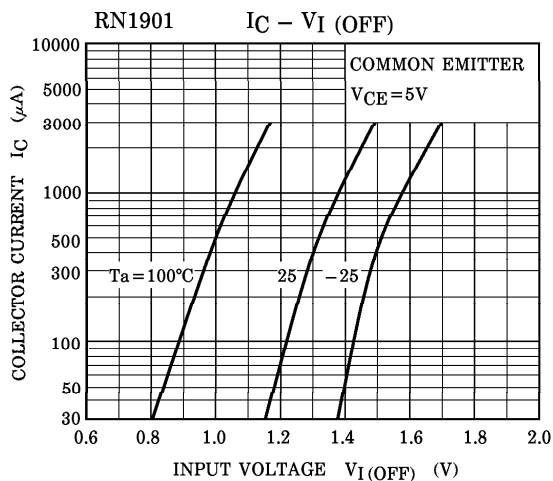

(Q1, Q2 COMMON)

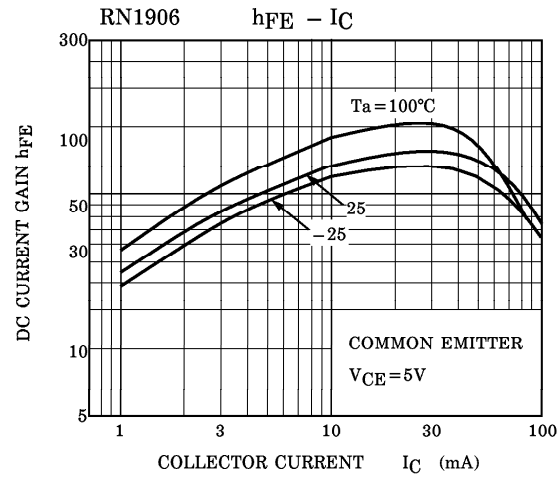
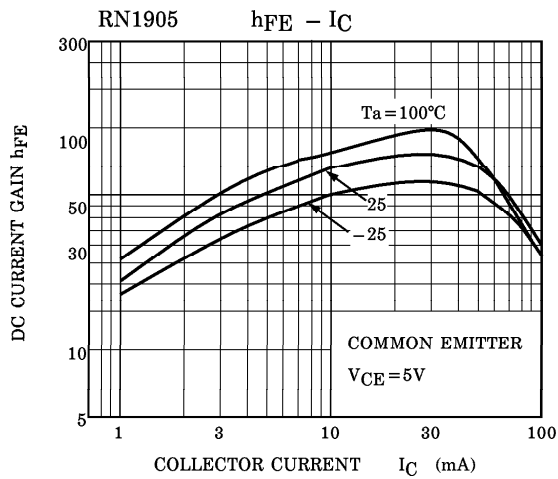
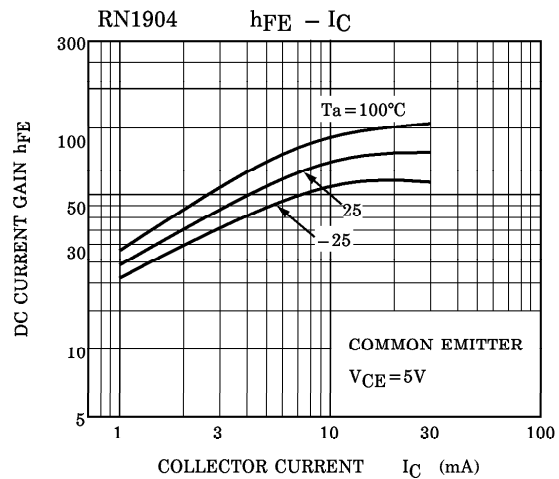
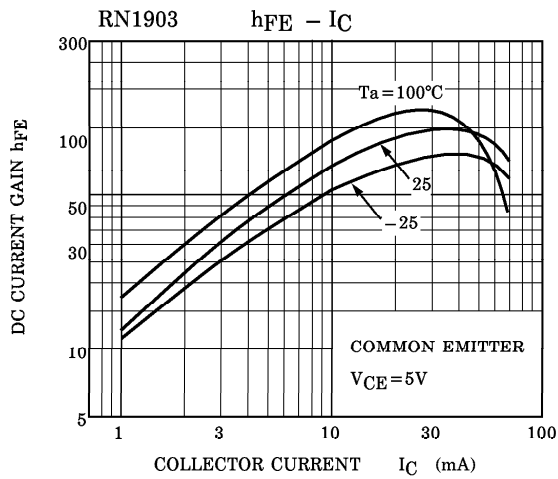
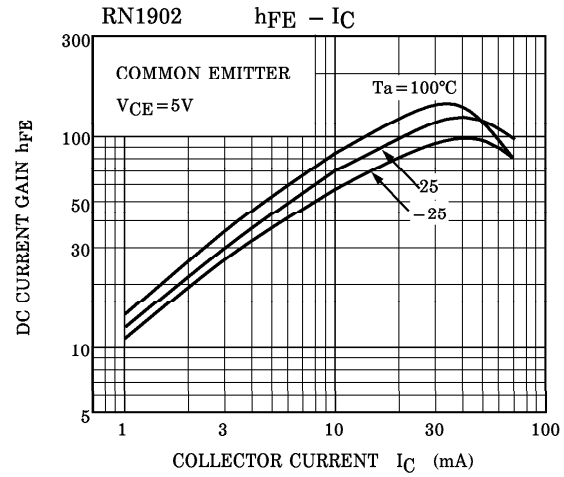
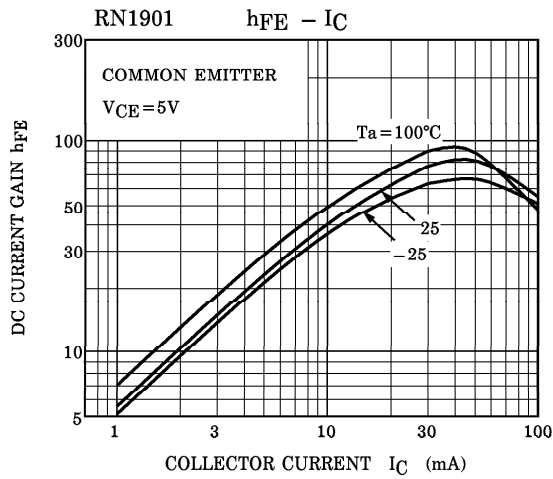

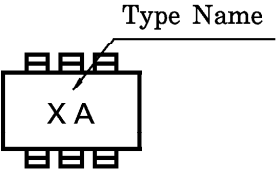
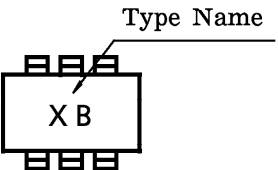
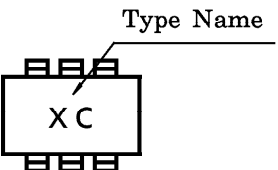
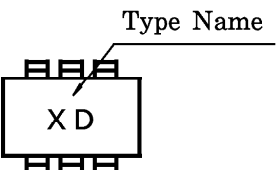
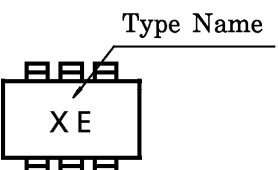
TYPE NAME	MARKING
RN1901	
RN1902	
RN1903	
RN1904	
RN1905	
RN1906	