

OKI Semiconductor

MSM7662

NTSC/PAL Digital Video Decoder

GENERAL DESCRIPTION

The MSM7662 is an LSI device that decodes NTSC or PAL analog video signals into YCbCr and RGB digital data based on ITU-RBT.601.

The device has built-in two channels of A/D converters and can accept composite video and S video signals for the input video signals. Composite video signals are converted to YCbCr and RGB digital data via the 2-dimensional Y/C separation circuit with an adaptive filter.

Analog video signals can be sampled by a clock at the pixel frequency or at twice the pixel frequency. A decimation filter is built-in for sampling at twice the pixel frequency.

Input signals are synchronized internally and high-speed locking for color burst is possible. Because a FIFO buffer is built into the output format circuit, jitter-free output can be obtained even for non-standard signals.

FEATURES (• new feature not found on MSM7661)

- Input analog signal
 - NTSC/PAL composite video signal or S-video signal
- 5 composite, 2 S-video analog inputs (switchable)
- Built-in clamp circuits and video amps
- Built-in 8-bit A/D converters (2 channels; sampling frequency: 40 MHz)
- 4 selectable output interfaces
 - ITU-RBT.656 (conditional), 8-bit (YCbCr), 8-bit (Y) + 8-bit (CbCr)
 - YCbCr = 4 : 2 : 2, YCbCr = 4 : 1 : 1 (limit)
 - 24-bit RGB RGB = 4 : 4 : 4
- 2-dimensional Y/C separation using adaptive comb filter (this filter is bypassed for S-video signal input)
 - NTSC format: 3 lines or 2 lines, PAL format: 2 lines (3 virtual lines)
- Selectable input signal synchronization
 - 4 synchronization modes: FIFO-1, FIFO-2, FM-1, FM-2 (FIFO-1 is normally selected)
 - (FIFO-1 and FIFO-2 use the internal FIFO, FM-1 and FM-2 use external field memory)
- Compatible pixel frequencies
 - 13.5 MHz (ITU-RBT.601), 12.27 MHz (NTSC Square Pixel)
 - 14.31818 MHz (NTSC 4fsc), 14.45 MHz (PAL Square Pixel)
- Built-in AGC/ACC circuits, compatible with a wide range of input levels
 - Input level range: -8 dB to +3.5 dB
 - Switchable between AGC/MGC (fixed gain) and ACC/MCC (fixed gain)
- Decimation filter built into input stage, allows easy configuration of filter prior to A/D converter
- Automatic NTSC/PAL recognition (only for ITU-RBT.601)
- Sleep mode
- Multiplex signal recognition (closed caption)
 - During vertical blanking interval, data is output as 8-bit data.
- I²C-bus interface
- 3.3 V single power supply (I/O 5 V tolerance)
- Package:
 - 100-pin plastic TQFP (TQFP100-P-1414-0.50-K) (Product name: MSM7662TB)

BLOCK DIAGRAM

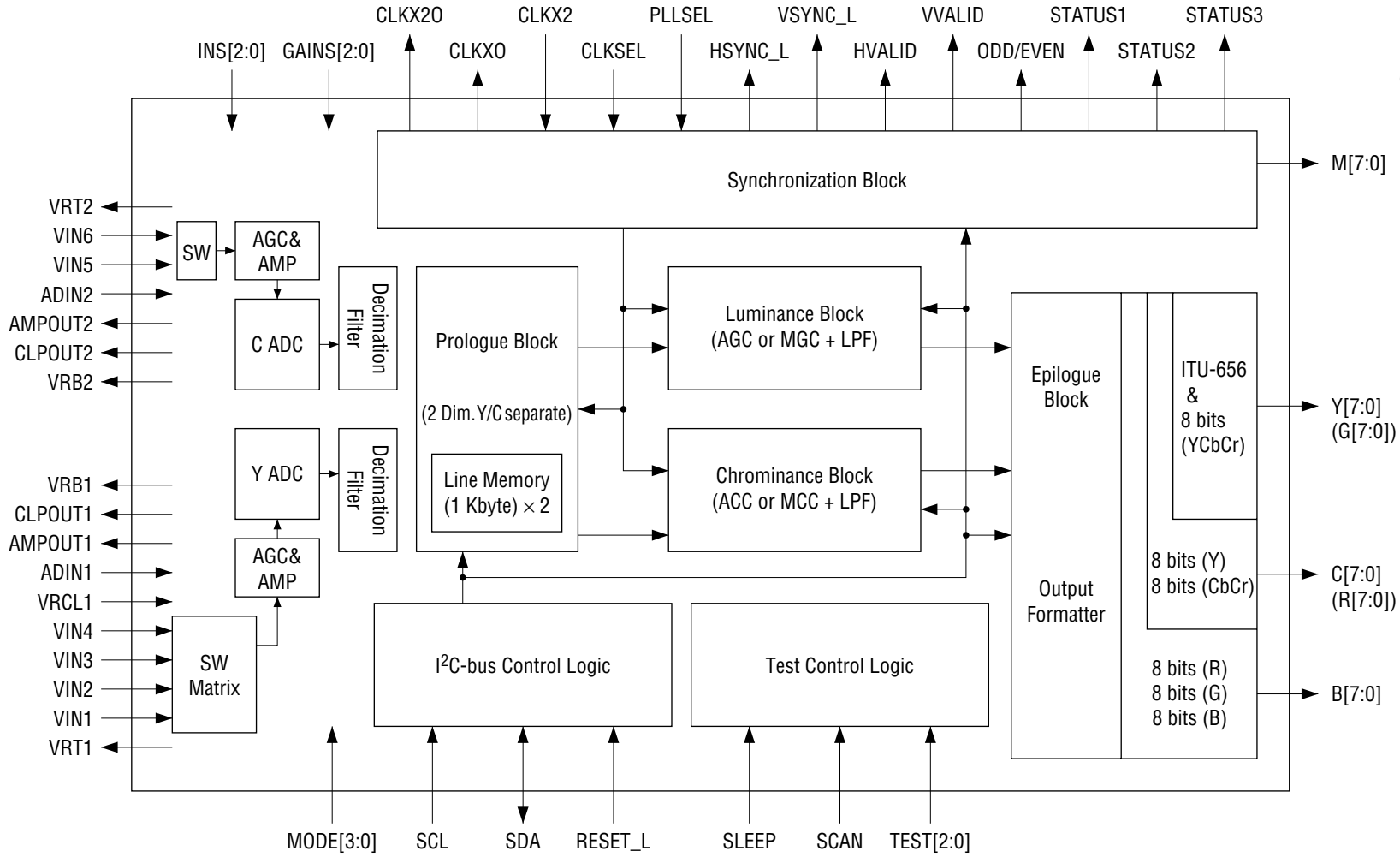

PIN CONFIGURATION (TOP VIEW)

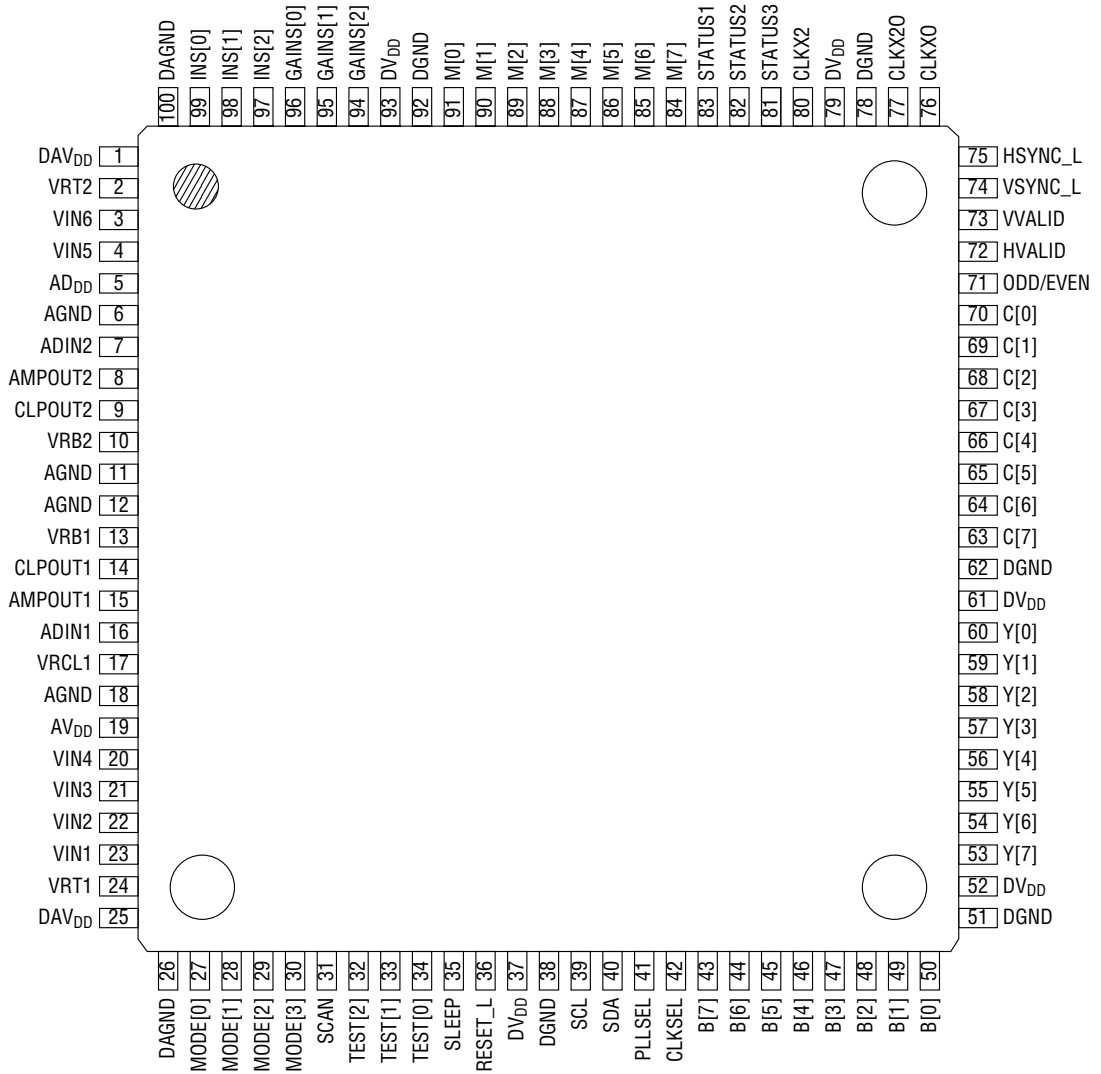

100-Pin Plastic TQFP

PIN DESCRIPTIONS

| Pin | Symbol | Type | Description |
|----------|-------------------|------|--|
| 1 | DAV _{DD} | — | Digital power supply in A/D converter |
| 2 | VRT2 | 0 | A/D converter reference voltage (high side) for chroma signal |
| 3 | VIN6 | I | Chroma signal input pin (leave open or connect to AGND when not used) |
| 4 | VIN5 | I | Chroma signal input pin (leave open or connect to AGND when not used) |
| 5 | AV _{DD} | — | Analog power supply |
| 6 | AGND | — | Analog ground |
| 7 | ADIN2 | I | A/D converter input pin for chroma signal |
| 8 | AMPOUT2 | 0 | Chroma signal amp output |
| 9 | CLPOUT2 | 0 | Chroma signal clamp voltage output |
| 10 | VRB2 | 0 | A/D converter reference voltage (low side) for chroma signal |
| 11 | AGND | — | Analog ground |
| 12 | AGND | — | Analog ground |
| 13 | VRB1 | I | A/D converter reference voltage (low side) for composite/luminance signal |
| 14 | CLPOUT1 | 0 | Composite/luminance signal clamp voltage output |
| 15 | AMPOUT1 | 0 | Composite/luminance signal amp output |
| 16 | ADIN1 | I | A/D converter input pin for composite/luminance signal |
| 17 | VRCL1 | I | Luminance signal clamp voltate input |
| 18 | AGND | — | Analog ground |
| 19 | AV _{DD} | — | Analog power supply |
| 20 | VIN4 | I | Composite/luminance signal input (leave open or connect to AGND when not used) |
| 21 | VIN3 | I | Composite/luminance signal input (leave open or connect to AGND when not used) |
| 22 | VIN2 | I | Composite/luminance signal input (leave open or connect to AGND when not used) |
| 23 | VIN1 | I | Composite/luminance signal input (leave open or connect to AGND when not used) |
| 24 | VRT1 | 0 | A/D converter reference voltage (high side) for composite/luminance signal |
| 25 | DAV _{DD} | — | Digital power supply in A/D converter |
| 26 | DAGND | — | Digital ground in A/D converter |
| 27 to 30 | MODE[3:0] | I | <p>Mode selection pins (pulled-down by internal resistors)</p> <p>MODE[3:2] Output mode selection 00: ITU-RBT.656 (with SAV, EAV, blank processing) 01: ITU-RBT.656 (no SAV, EAV, blank processing) 10: ITU-RBT.601 11: RGB</p> <p>MODE[1] 0: NTSC 1: PAL MODE[0] 0: ITU-RBT.601 1: Square Pixel</p> <p>If an ITU-R.601 signal is input while registers are set to automatic NSTC/PAL recognition, NTSC/PAL will be automatically recognized regardless of the MODE1 setting.</p> |

PIN DESCRIPTIONS (continued)

| Pin | Symbol | Type | Description |
|----------|-----------------------|------|--|
| 31 | SCAN | I | Test input. Normally fixed at "0" (pulled down by internal resistor). |
| 32 | TEST[2] | I | Test input. Normally fixed at "0" (pulled down by internal resistor). |
| 33 | TEST[1] | I | Test input. Normally fixed at "0" (pulled down by internal resistor). |
| 34 | TEST[0] | I | Test input. Normally fixed at "0" (pulled down by internal resistor). |
| 35 | SLEEP | I | 0: normal operation, 1: sleep operation |
| 36 | RESET_L | I | Reset input pin (active "L") |
| 37 | DV _{DD} | — | Digital power supply |
| 38 | DGND | — | Digital ground |
| 39 | SCL | I | I ² C-bus clock input |
| 40 | SDA | I/O | I ² C-bus data I/O pin |
| 41 | PLLSEL | I | Internal/external sync switching pin (pulled down by internal resistor). 0: Internal sync mode, 1: External sync mode; use external PLL |
| 42 | CLKSEL | I | Clock select input pin (pulled down by internal resistor). "L": double-speed 27 MHz, "H": normal clock 13.5 MHz |
| 43 to 50 | B[7:0] | I/O | B data output during RGB mode B[7]: MSB, B[0]: LSB |
| 51 | DGND | — | Digital ground |
| 52 | DV _{DD} | — | Digital power supply |
| 53 to 60 | Y[7:0] | O | ITU-RBT.656 data output during ITU-RBT.656 output mode ITU-RBT.601 luminance data output during ITU-RBT.601 output mode G data output during RGB mode, Y[7]: MSB, Y[0]: LSB |
| 61 | DV _{DD} | — | Digital power supply |
| 62 | DGND | — | Digital ground |
| 63 to 70 | C[7:0] | I/O | Chroma data output during ITU-RBT.601 output mode R data output during RGB mode, C[7]: MSB, C[0]: LSB |
| 71 | ODD/EVEN | O | Field display output If field is odd, "H" is output |
| 72 | HVALID | O | Horizontal valid pixel timing output pin |
| 73 | VVALID | O | Vertical valid line timing output pin |
| 74 | VS _{SYNC} _L | O | V sync output pin |
| 75 | HS _{SYNC} _L | O | H sync output pin |
| 76 | CLKXO | O | Pixel clock output |
| 77 | CLKX20 | O | System clock output |
| 78 | DGND | — | Digital ground |
| 79 | DV _{DD} | — | Digital power supply |
| 80 | CLKX2 | I | System clock input |
| 81 | STATUS[3] | O | Default is internal FIFO overflow detection (TV, VTR mode switching guide) 0: non-detection, 1: detection CSYNC output (selected by register) When PLLSEL external sync mode is selected, HSYNC output |

PIN DESCRIPTIONS (continued)

| Pin | Symbol | Type | Description |
|----------|------------------|------|---|
| 82 | STATUS[2] | 0 | Default is NTSC-PAL recognition 0: NTSC, 1: PAL HLOCK sync detection display output (selected by register) 0: non-detection, 1: detection |
| 83 | STATUS[1] | 0 | VBI interval multiplex signal detection output 0: non-detection, 1: detection |
| 84 | M[7] | I/O | Field memory control signal; RE output |
| 85 | M[6] | I/O | Field memory control signal; WE output |
| 86 | M[5] | I/O | Field memory control signal; RSTR output |
| 87 | M[4] | I/O | Field memory control signal; RSTW output |
| 88 | M[3] | I/O | Test output pin, normally "L" output |
| 89 | M[2] | I/O | Slave address select "L": 1000001X "H": 1000011X (no internal pull-up or pull-down resistor) |
| 90 | M[1] | I/O | Pin for setting by either external pin or internal register in order to select analog section gain value and video signal input pin. "L": external pin setting "H": internal register setting (no internal pull-up or pull-down resistor) |
| 91 | M[0] | I/O | Test I/O pin, normally fixed at "H" (no internal pull-up or pull-down resistor) |
| 92 | DGND | — | Digital ground |
| 93 | DV _{DD} | — | Digital power supply |
| 94 to 96 | GAINS[2:0] | I | Inputs for amp gain switch setting during external setting mode (pulled down by internal resistors) |
| 97 to 99 | INS[2:0] | I | Inputs for signal input pin switch setting during external setting (pulled down by internal resistors) |
| 100 | DAGND | — | Digital ground in A/D converter |

ABSOLUTE MAXIMUM RATINGS

| Parameter | Symbol | Condition | Rating | Unit |
|----------------------|-----------|----------------------------|--------------|--------------------|
| Power Supply Voltage | V_{DD} | $T_a = 25^{\circ}\text{C}$ | -0.3 to +4.5 | V |
| Input Voltage | V_I | $V_{DD} = 3.3\text{ V}$ | -0.3 to +5.5 | V |
| Power Consumption | P_W | — | 1 | W |
| Storage Temperature | T_{STG} | — | -55 to +150 | $^{\circ}\text{C}$ |

RECOMMENDED OPERATING CONDITIONS

| Parameter | Symbol | Condition | Min. | Typ. | Max. | Unit |
|---------------------------------|----------------|------------------------------|---------------------|------|----------|--------------------|
| Power Supply Voltage | V_{DD} | $T_a = 25^{\circ}\text{C}$ | 3.0 | 3.3 | 3.6 | V |
| Power Supply Voltage | GND | $T_a = 25^{\circ}\text{C}$ | — | 0 | — | V |
| Digital "H" Level Input Voltage | V_{IH1} | — | 2.2 | — | V_{DD} | V |
| | $V_{IH2} (*1)$ | — | $0.8 \times V_{DD}$ | — | V_{DD} | V |
| Digital "L" Level Input Voltage | V_{IL} | — | 0 | — | 0.8 | V |
| Analog Video Signal Input | V_{AIN} | SYNC tip to white peak level | 0.8 | — | 1.1 | V_{P-P} |
| Operating Temperature | T_a | — | 0 | — | 70 | $^{\circ}\text{C}$ |

*1: CLKX2, SDA

ELECTRICAL CHARACTERISTICS

DC Characteristics

(Ta = 0 to 70°C, V_{DD} (DV_{DD}, ADV_{DD}, AV_{DD}) = 3.3 V ±0.3 V)

| Parameter | Symbol | Condition | Min. | Typ. | Max. | Unit |
|--------------------------|-------------------|---|-----------------------|------|-----------------|------|
| "H" Level Output Voltage | V _{OH} | I _{OH} = -4 mA (*1) | 0.7 × V _{DD} | — | V _{DD} | V |
| | | I _{OH} = -6 mA (*2) | | | | |
| "L" Level Output Voltage | V _{OL} | I _{OL} = 4 mA (*1) | 0 | — | 0.8 | V |
| | | I _{OL} = 6 mA (*2) | | | | |
| Input Leakage Current | I _{LI} | V _I = GND to V _{DD} | -10 | — | +10 | μA |
| | | R _{pull_down} = 50 kΩ (*3) | -250 | — | -20 | μA |
| Output Leakage Current | I _{LO} | V _I = GND to V _{DD} | -10 | — | +10 | μA |
| SDA Output Voltage | SDAV _L | — | 0 | — | 0.4 | V |
| SDA Output Current | SDAI _O | — | 3 | — | — | mA |

*1: HSYNC_L, VSYNC_L, SYSEL, C[7:0], B[7:0], ODD, VVALID, HVALID, CLKXO, HSY

*2: Y[7:0], CLKX2O

*3: MODE[3:0], TE, TEST1, T0, T1, PLLSEL, CLKSEL, M[3:0], ATEST[3:1], INS[3:1]

DC Characteristics (Analog Unit)

(Ta = 0 to 70°C, V_{DD} (DV_{DD}, ADV_{DD}, AV_{DD}) = 3.3 V ±0.3 V)

| Parameter | Symbol | Condition | Min. | Typ. | Max. | Unit |
|-----------------------|--------------------|------------------------|-----------------|------|-----------------|------------------|
| AMPOUT Output Voltage | V _{OAMP} | R _O = 330 Ω | 0.2 | — | 2.6 | V |
| CLPOUT Output Voltage | V _{OCLP} | R _O = 5 kΩ | 0.2 | — | 1.6 | V |
| VRT Output Voltage | V _{RT} | — | 2.05 | 2.3 | 2.4 | V |
| VRB Output Voltage | V _{RB} | — | 0.15 | 0.3 | 0.4 | V |
| ADIN | V _{IADIN} | — | V _{RB} | — | V _{RT} | V |
| VIN | V _{IVIN} | Capacitive coupling | 0.4 | — | 1.3 | V _{P-P} |
| Input Current | I _{IVIN} | V _I = 1.5 V | 60 | 100 | 200 | μA |

DC Characteristics

(Ta = 0 to 70°C, V_{DD} (DV_{DD}, ADV_{DD}, AV_{DD}) = 3.3 V ±0.3 V)

| Parameter | Symbol | Condition | Min. | Typ. | Max. | Unit |
|----------------------------------|-----------------|---------------------------|------|------|------|------|
| Power Supply Current (Operating) | I _{D1} | AD1 on | 150 | 210 | TBD | mA |
| | | AD1 off CLKX2 = 27 MHz | | | | |
| Power Supply Current (Operating) | I _{D2} | AD1 on | 190 | 240 | TBD | mA |
| | | AD2 on CLKX2 = 27 MHz | | | | |
| Power Supply Current (Sleep) | I _{DS} | V _I = 1.5 V | 0.2 | 1 | 5 | mA |

AC Characteristics (Single Speed Mode)

(Ta = 0 to 70°C, V_{DD} (DV_{DD}, ADV_{DD}, AV_{DD}) = 3.3 V ±0.3 V)

| Parameter | Symbol | Condition | Min. | Typ. | Max. | Unit |
|---|--------------------|-------------------------------|------|-------|------|------|
| CLKX2 Cycle Time | t _{CLKX1} | ITU-RS601 | — | 74.07 | — | ns |
| | | NTSC 4fsc | — | 69.84 | — | ns |
| | | NTSC Square Pixel | — | 81.5 | — | ns |
| | | PAL Square Pixel | — | 67.8 | — | ns |
| CLKX1 Duty | t _{D_D1} | CLKSEL : H | 40 | | 60 | % |
| | | | | | | |
| | | | | | | |
| Output Data Delay Time 1 (*) | t _{OD11} | — | 7 | — | 28 | ns |
| Output Data Delay Time 2 (*) | t _{OD12} | — | 7 | — | 35 | ns |
| Output Clock Delay Time (*) (CLKX2-CLKX0) | t _{CXD11} | CLKSEL : H | 3 | — | 22 | ns |
| Output Clock Delay Time (*) (CLKX2-CLKX20) | t _{CXD12} | CLKSEL : H | 3 | — | 16 | ns |
| SCL Clock Cycle Time | t _{C_SC1} | R _{pull_up} = 4.7 kΩ | 200 | — | — | ns |
| SCL Clock Duty | t _{D_SC1} | — | — | 50 | — | % |
| SCL Low Level Cycle | t _{L_SC1} | R _{pull_up} = 4.7 kΩ | 100 | — | — | ns |

(*) Output load: 15 pF

AC Characteristics (Double Speed Mode)

(Ta = 0 to 70°C, V_{DD} (DV_{DD}, ADV_{DD}, AV_{DD}) = 3.3 V ±0.3 V)

| Parameter | Symbol | Condition | Min. | Typ. | Max. | Unit |
|---|--------------------|-------------------------------|------|-------|------|------|
| CLKX2 Cycle Time | t _{CLKX2} | ITU-RS601 | — | 37.05 | — | ns |
| | | NTSC 4fsc | — | 34.9 | — | ns |
| | | NTSC Square Pixel | — | 40.75 | — | ns |
| | | PAL Square Pixel | — | 33.9 | — | ns |
| CLKX2 Duty | t _{D_D2} | — | 45 | — | 55 | % |
| | | | | | | |
| | | | | | | |
| Output Data Delay Time 1 (*) | t _{OD21} | CLKSEL : L | 8 | — | 28 | ns |
| Output Data Delay Time 2 (*) | t _{OD22} | CLKSEL : L | 8 | — | 34 | ns |
| Output Clock Delay Time (*) (CLKX2-CLKX0) | t _{CXD21} | CLKSEL : L | 6 | — | 22 | ns |
| Output Clock Delay Time (*) (CLKX2-CLKX20) | t _{CXD22} | CLKSEL : L | 5 | — | 16 | ns |
| SCL Clock Cycle Time | t _{C_SCL} | R _{pull_up} = 4.7 kΩ | 200 | — | — | ns |
| SCL Clock Duty | t _{D_SCL} | — | — | 50 | — | % |
| SCL Low Level Cycle | t _{L_SCL} | R _{pull_up} = 4.7 kΩ | 100 | — | — | ns |

(*) Output load: 15 pF

INPUT AND OUTPUT TIMING

Clock and Output Timing

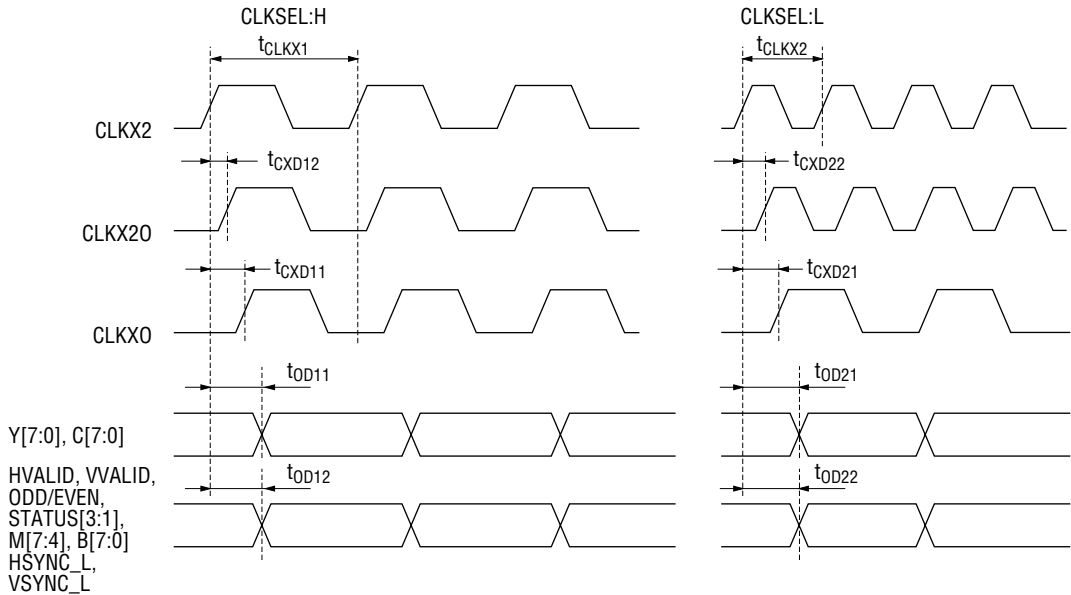

I²C-bus Interface Input/Output Timing

The basic input/output timing of the I²C-bus is indicated below.

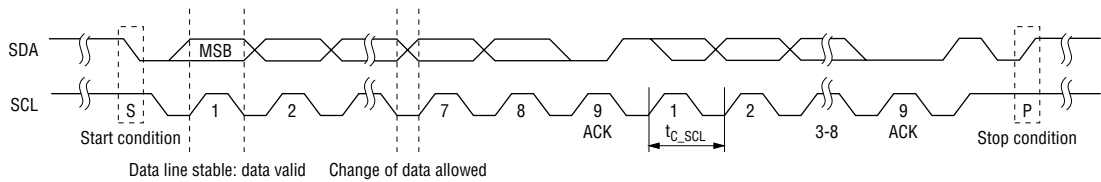

FUNCTIONAL DESCRIPTION

Analog Unit

- 1) Analog input select: Compatible with composite video signals and S-video signals. Input selection can be switched by register control via the I²C-bus or by external pins. (See the below chart for pin combinations.)
- 2) Clamp function: An analog clamp and a digital pulse clamp can be used.
 Analog clamp (HSY = 1)*
 Analog clamp → HSY clamp (digital clamp)
 HSY clamp (digital clamp)
 Only the HSY clamp can be set as the pedestal clamp.
- 3) AGC amp: The AGC function operates depending upon the input level.
 Manual gain setting is also possible. This AGC function operates at 2 stages, the analog unit and digital unit. Digital decoded data is output in conformance with ITU-RBT.601.
- 4) A/D converter: Two internal 8-bit A/D converters sample at twice the pixel frequency. (Sampling at the pixel frequency is possible by changing the register setting.)

List of Analog Input Conditions

| Input Signal | @Control Pin | Input Pin | | | | | | ADC Selection | |
|------------------|--------------|-------------|-----------|-----------|-----------|-----------|--------|---------------|-----|
| | INS[2:0] | VIN1 | VIN2 | VIN3 | VIN4 | VIN5 | VIN6 | ON | OFF |
| Composite Input* | [000] | Composite | | | | | | ON | OFF |
| Composite Input | [001] | | Composite | | | | | ON | OFF |
| Composite Input | [010] | | | Composite | | | | ON | OFF |
| Composite Input | [011] | | | | Composite | | | ON | OFF |
| Composite Input | [100] | | | | | Composite | | ON | OFF |
| S-video Input | [101] | Luminance | | | | Chroma | | ON | ON |
| S-video Input | [110] | | Luminance | | | | Chroma | ON | ON |
| All inputs Off | [111] | OFF (Sleep) | | | | | | OFF | OFF |

Blank spaces: non-selectable *: register default setting after LSI reset

@: These pin settings are valid during external mode setting. In the internal register mode, the register contents will be changed.

Manual Gain Control (analog AMP gain)

| Gain Setting Pins GAINS[2:0] | Set Gain Value Typ. Value (multiplication factor) |
|---------------------------------|--|
| [000] | 1.0 |
| [001] | 1.35 |
| [010] | 1.75 |
| [011] | 2.3 |
| [100] | 3.0 |
| [101] | 3.8 |
| [110] | 5.0 |
| [111] | 2.0 |

Decoder Unit

1. Prologue Block

The prologue block inputs data and performs Y/C separation.

Data can be input at either the pixel frequency (ITU-R: 13.5 MHz) or at twice the pixel frequency (ITU-R: 27 MHz). If input at twice the pixel frequency, data is processed after passing through a decimator circuit to convert it to the pixel frequency. The decimator circuit may be bypassed by changing the register setting, regardless of whether data is input at the normal pixel frequency or at twice the pixel frequency.

If a composite signal (CVBS) is input, the default setting performs Y/C separation using a 2-dimensional adaptive comb filter.

The following operating modes can be selected via the I²C-bus. Default settings are indicated by an asterisk (*). The default state is selected at reset.

- 1) Video input mode selection
 - Composite video input *
 - S-video input
- 2) Video input mode selection
 - NTSC/PAL auto-select* (only for ITU-R.601)
 - Dependent upon operating mode selected

When ITU-R.601 is selected, the video input mode is automatically set depending upon the number of lines per field.

- 3) Operating mode selection

| | |
|-------------------|--------------|
| NTSC ITU-R.601 | 13.5 MHz* |
| NTSC Square Pixel | 12.27 MHz |
| NTSC 4fsc | 14.31818 MHz |
| PAL ITU-R.601 | 13.5 MHz |
| PAL Square Pixel | 14.75 MHz |
- 4) Decimator circuit pass/bypass selection
 - Pass through decimator circuit*
 - Bypass decimator circuit
- 5) Y/C separation mode selection
 - Use adaptive comb filter*
 - Use non-adaptive comb filter
 - Do not use comb filter (use trap filter)

The adaptive comb filter makes the correlation between up to 3 consecutive lines (only 2 lines in the case of a PAL signal). If there is correlation, Y/C separation is performed by the comb filter according to the format of correlation.

The non-adaptive comb filter performs Y/C separation by removing the luminance component based on the average of preceding and following lines (when there is correlation between 3 lines). When a comb filter is not used, Y/C separation is performed by a trap filter.

If an S-video signal is input, these Y/C separation circuits are bypassed.

The functions of this block only operate when lines are valid as image information. During the V blanking interval, CVBS signals are not processed.

2. Luminance Block

The luminance block removes synchronous signals from signals containing luminance components after Y/C separation. The signals are compensated and then output as luminance signals. Two modes of gain control functions can be selected for the luminance signal output level: AGC (Auto Gain Control) and MGC + Pedestal Clamp.

In the AGC mode, luminance level amplification is determined by comparing the SYNC depth with a reference value. The default is 40IRE and can be changed by the register setting. The input has a sync chip clamp.

In the MGC + Pedestal Clamp mode, the signal output level is clamped to the pedestal level of the input. Signal amplification and black level can be changed from the clamped position by register settings.

This block can select the following operating modes.

1) Selection of prefilter and sharp filter usage

Do not use*

Use

These filters are used to enhance the edges of luminance component signals.

2) Selection of aperture bandpass filter coefficient

Middle range*

High range

3) Coring range selection

Off*

±4LBS

±5LBS

±7LBS

4) Aperture weighting coefficient selection

0*

0.25

0.75

1.5

Both coring and aperture compensation processes perform contour compensation.

5) Selection of pixel position compensating circuit usage

Use*

Do not use

6) AGC loop filter time constant selection

Slow coefficient value 1/1024n

Medium 1/64n*

Fast 1/n

Fixed 0

Fixed: manual gain setting is possible

- 7) Parameter for fine adjustment of AGC sync depth
- 8) Parameter for fine adjustment of sync removal level
The black level is adjusted. The default setting outputs the pedestal position as a black level (=16).
- 9) Pedestal clamp selection
Do not use pedestal clamp*
Use pedestal clamp (at this time, AGC does not operate, MGC operates)

3. Chrominance Block

This block processes the chroma signals.
The following operating modes can be selected.

- 1) Selection of color bandpass filter usage
Do not use*
Use
- 2) ACC loop filter time constant selection

| | | |
|--------|-------------------|---------|
| Slow | coefficient value | 1/1024m |
| Medium | | 1/64m* |
| Fast | | 1/m |
| Fixed | | 0 |

Fixed: manual gain setting is possible
- 3) ACC reference level fine adjustment
- 4) Parameter for burst level fine adjustment
- 5) Threshold level at which chroma amplitude becomes valid is selected based upon color burst ratio.
 - 0.5
 - 0.25*
 - 0.125
 - Off

Off: The color killer function is turned off. If decoloration occurs while decoding a still picture, setting the threshold level to "off" will reduce the decoloration.
- 6) Color killer mode selection
 - Auto color killer mode*
 - Forced color killer
- 7) Parameter for fine adjustment of color subcarrier phase

In this block, chroma signals pass through a bandpass filter to cut out unnecessary band. To maintain a constant chroma level, these signals then pass through an ACC compensating circuit and are UV demodulated. (The filter can be bypassed.) If the demodulated result does not reach a constant level, color killer signals are generated to fix the ACC gain. This functions as an auto color killer control circuit. The UV demodulated results pass through a low-pass filter and are output as chrominance signals.

4. Synchronization Block

This block processes the sync signals. Synchronous signals are generated for chip output and for internal use. Various signals are output from this block and the following operating modes can be selected.

- 1) Adjustment of SYNC threshold level (internal sync)
- 2) HSY control
 - 2-1) Fine adjustment of HSY signal (start side)
 - 2-2) Fine adjustment of HSY signal (stop side)
- 3) HSY signal enable selection

High Level*
Active
Low Level

The HSY signal provides the sync-tip-clamp processing for the A/D converter.

- 4) Fine adjustment of HSYNC_L signal
- 5) HVALID control
 - 5-1) Fine adjustment of HVALID signal (start side)
 - 5-2) Fine adjustment of HVALID signal (stop side)
- 6) VVALID control
 - 6-1) Fine adjustment of VVALID signal (start side)
 - 6-2) Fine adjustment of VVALID signal (stop side)

Data signals are transferred at the rising edge of the HVALID signal.

- 7) FIFO and Field Memory mode selection

FIFO-1 mode*: Sets and outputs a standard value for the number of pixels per 1H from the internal FIFO.

This mode is also compatible (to a degree) with non-standard VTR signals.

FIFO-2 mode: Sets and outputs a constant pixel number corresponding to the input H interval for the number of pixels per 1H from the internal FIFO.

FM-1 mode: This mode outputs the decoded results according to the SYNC signal.

Usage of external field memory is required to manage the number of pixels and to absorb jitter.

Memory control signals are to be generated externally.

FM-2 mode: This mode is compatible with considerably distorted non-standard VTR signals. Jitter is absorbed by using external field memory (2 Mb×2) and the standard value is set as the pixel number.

Field memory control signals are output simultaneously from M[7:4].

- 8) Field memory control signals

If the FM-1 mode uses external field memory (2 Mb × 2) instead of the internal FIFO, field memory control signals are supplied from pins M[7:4].

5. Epilogue Block

The Epilogue Block outputs the UV signal from the Chrominance block and the Y signal from the Luminance block in a format based on a signal obtained from the control register setting. This block can select the following modes.

- 1) Output mode selection
 - 1-1) ITU-RBT.656 (SAV, EAV, blank processing)
 - 1-2) * 8-bit (YCbCr) output (2x pixel clock) synchronization with HSYNC_L, VSYNC_L
 - 1-3) 16-bit (8-bit Y/8-bit CbCr) (pixel clock) synchronization with HSYNC_L, VSYNC_L
 - 1-4) 24-bit RGB (8 bits each) synchronization with HSYNC_L, VSYNC_L
- 2) Enable Blue Back display when synchronization fails
 - OFF
 - ON*
- 3) Selection of YCbCr signal output format
 - YCbCr 4 : 2 : 2*
 - YCbCr 4 : 1 : 1

The chrominance signal (U, V component) outputs Cb and Cr data to the C pin in an output format to be described later.
- 4) Selection of 8-bit chroma signal output format
 - Offset binary*
 - 2's complement
- 5) Output pin enable selection
 - High-impedance
 - Output enable*
- 6) Multiplex signal (VBI data) detection level adjustment

The levels to detect multiplexed signals sent during the vertical blanking period are configured to be variable. The binary values after input signals are A-to D converted are employed as the levels to detect multiplexed signals, and the levels are set in eight steps with respect to the SYNC tip level. (See page 26 and page 27)
- 7) Various mode detection
 - NTSC/PAL detection
 - Multiplex signal detection
 - HSYNC synchronization detection
 - Iinternal FIFO overflow detection
- 8) Output signal phase control

Y and C phases can each be adjusted in the range of -2 to +1 pixels.

6. I²C Control Block

This serial interface block is based on the I²C standard of the Phillips Corporation. This block only functions as a Slave-Receiver (write mode).

7. Test Control Block

This block is used to test the LSI chip. Normally this block is not used.

Input Signal Level

The figure below shows the ideal range of the input signal, considered as an 8-bit straight binary value.

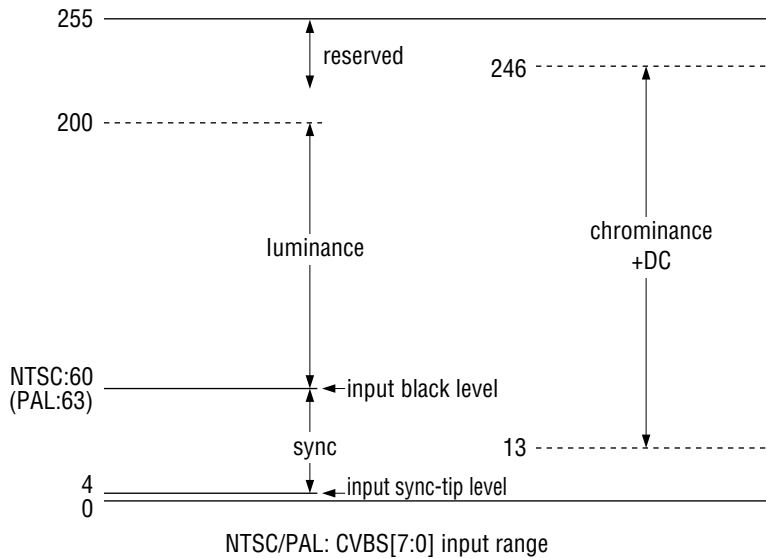

The above input conditions are ideal. Because analog signals are normally input at different levels, the exact settings described above are difficult to achieve. While maintaining the ratio of White Peak (100%)/SYNC = 100IRE/40IRE (NTSC), if the input signal is set within the A/D converter's voltage range, the Y digital output will be output with Black Level = 16 and White Peak (100%) = 235.

Output format

ITU-RBT.656 output, 8-bit (YCbCr) output, and 16-bit (8-bit Y/8-bit CbCr) output have the following formats.

The YCbCr 4:2:2 format and 4:1:1 format are shown below.
The output format can be changed by register settings.

| Output | Pixel Byte Sequence | | | | | |
|----------|---------------------|-----|-----|-----|-----|-----|
| Y7 (MSB) | Y7 | Y7 | Y7 | Y7 | Y7 | Y7 |
| Y6 | Y6 | Y6 | Y6 | Y6 | Y6 | Y6 |
| Y5 | Y5 | Y5 | Y5 | Y5 | Y5 | Y5 |
| Y4 | Y4 | Y4 | Y4 | Y4 | Y4 | Y4 |
| Y3 | Y3 | Y3 | Y3 | Y3 | Y3 | Y3 |
| Y2 | Y2 | Y2 | Y2 | Y2 | Y2 | Y2 |
| Y1 | Y1 | Y1 | Y1 | Y1 | Y1 | Y1 |
| Y0 (LSB) | Y0 | Y0 | Y0 | Y0 | Y0 | Y0 |
| C7 (MSB) | Cb7 | Cr7 | Cb7 | Cr7 | Cb7 | Cr7 |
| C6 | Cb6 | Cr6 | Cb6 | Cr6 | Cb6 | Cr6 |
| C5 | Cb5 | Cr5 | Cb5 | Cr5 | Cb5 | Cr5 |
| C4 | Cb4 | Cr4 | Cb4 | Cr4 | Cb4 | Cr4 |
| C3 | Cb3 | Cr3 | Cb3 | Cr3 | Cb3 | Cr3 |
| C2 | Cb2 | Cr2 | Cb2 | Cr2 | Cb2 | Cr2 |
| C1 | Cb1 | Cr1 | Cb1 | Cr1 | Cb1 | Cr1 |
| C0 (LSB) | Cb0 | Cr0 | Cb0 | Cr0 | Cb0 | Cr0 |
| Y point | 0 | 1 | 2 | 3 | 4 | 5 |
| C point | 0 | | 2 | | 4 | |

YCbCr 4:2:2 format

| Output | Pixel Byte Sequence | | | | | | | |
|----------|---------------------|-----|-----|-----|-----|-----|-----|-----|
| Y7 (MSB) | Y7 | Y7 | Y7 | Y7 | Y7 | Y7 | Y7 | Y7 |
| Y6 | Y6 | Y6 | Y6 | Y6 | Y6 | Y6 | Y6 | Y6 |
| Y5 | Y5 | Y5 | Y5 | Y5 | Y5 | Y5 | Y5 | Y5 |
| Y4 | Y4 | Y4 | Y4 | Y4 | Y4 | Y4 | Y4 | Y4 |
| Y3 | Y3 | Y3 | Y3 | Y3 | Y3 | Y3 | Y3 | Y3 |
| Y2 | Y2 | Y2 | Y2 | Y2 | Y2 | Y2 | Y2 | Y2 |
| Y1 | Y1 | Y1 | Y1 | Y1 | Y1 | Y1 | Y1 | Y1 |
| Y0 (LSB) | Y0 | Y0 | Y0 | Y0 | Y0 | Y0 | Y0 | Y0 |
| C7 (MSB) | Cb7 | Cb5 | Cb3 | Cb1 | Cb7 | Cb5 | Cb3 | Cb1 |
| C6 | Cb6 | Cb4 | Cb2 | Cb0 | Cb6 | Cb4 | Cb2 | Cb0 |
| C5 | Cr7 | Cr5 | Cr3 | Cr1 | Cr7 | Cr5 | Cr3 | Cr1 |
| C4 | Cr6 | Cr4 | Cr2 | Cr0 | Cr6 | Cr4 | Cr2 | Cr0 |
| C3 | 0 | 0 | 0 | 0 | 0 | 0 | 0 | 0 |
| C2 | 0 | 0 | 0 | 0 | 0 | 0 | 0 | 0 |
| C1 | 0 | 0 | 0 | 0 | 0 | 0 | 0 | 0 |
| C0 (LSB) | 0 | 0 | 0 | 0 | 0 | 0 | 0 | 0 |
| Y point | 0 | 1 | 2 | 3 | 4 | 5 | 6 | 7 |
| C point | 0 | | | | 4 | | | |

YCbCr 4:1:1 format

Relation between video mode and pixel number (default settings when standard signal is input)

| Video Mode | Pixel Type | Pixel Rate (MHz) | Total Pixels | Active Pixels | Front-Porch | Hsync Back-Porch | HBLK Total |
|------------|--------------|------------------|--------------|---------------|-------------|------------------|------------|
| NTSC | ITUR.601 | 13.5 | 858 | 720 | 16 | 122 | 138 |
| | Square pixel | 12.27 | 780 | 640 | 28 | 112 | 140 |
| | 4fsc | 14.32818 | 910 | 768 | 8 | 134 | 142 |
| PAL | ITUR.601 | 13.5 | 864 | 720 | 12 | 132 | 144 |
| | Square pixel | 14.75 | 944 | 768 | 34 | 142 | 176 |

TIMING DESCRIPTION

Vertical Synchronizing Signal

The vertical synchronizing signal timing is as follows.

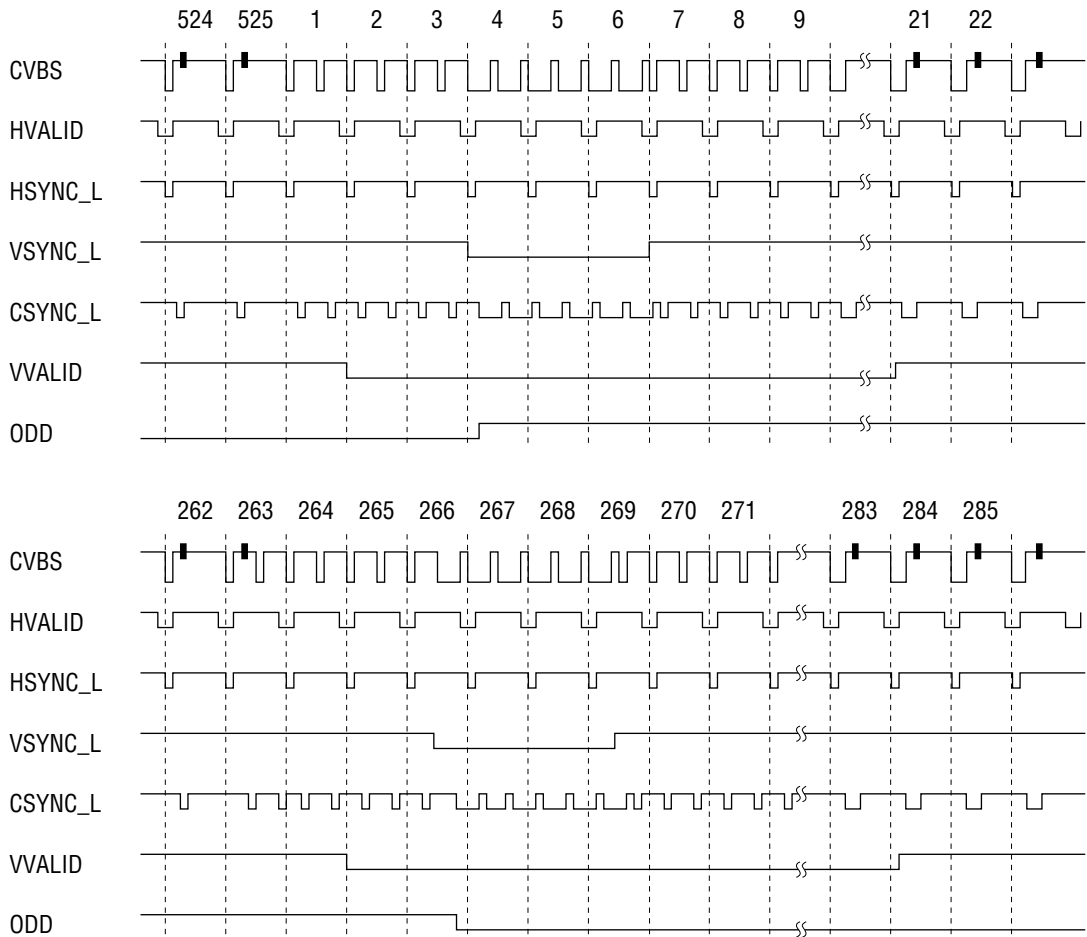

Vertical Synchronizing Signal (60 Hz)

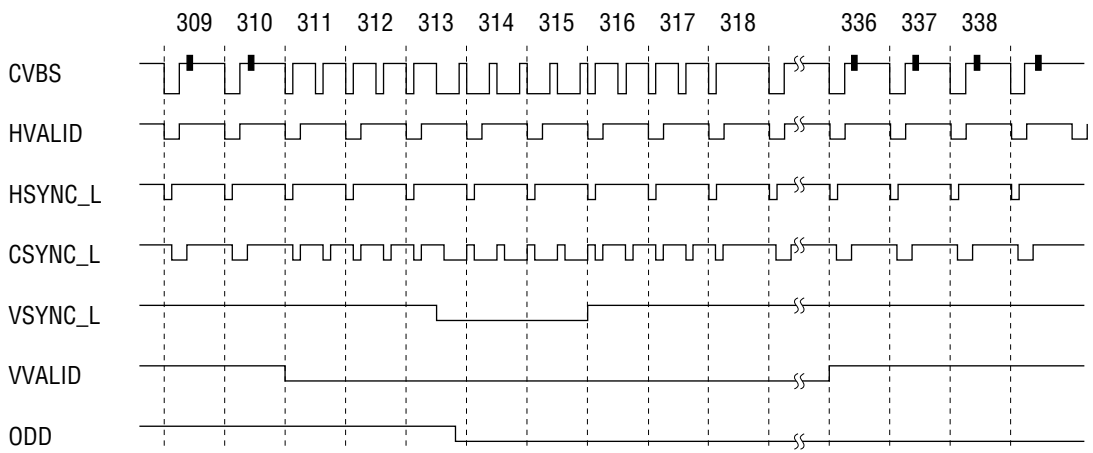
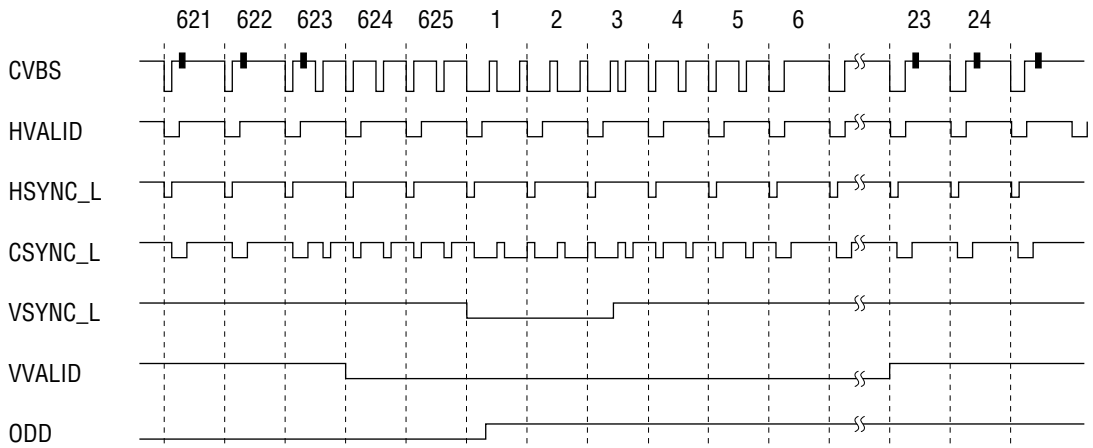

Vertical Synchronizing Signal (50 Hz)

A/D Converter Support Signal

The waveform of the HSY signal, shown below, provides clamp timing to the A/D converter when HSY clamp (digital clamp) is selected. The start and end edges of the clamp pulse have a variable range from the sync chip to the pedestal position.

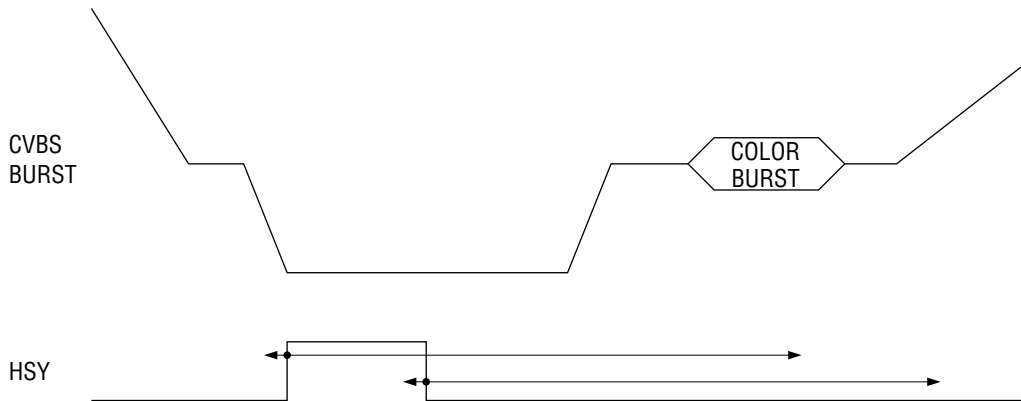

A/D Converter Support Signal

Output Timing

- ITU-R.656 output

T : clock periods 37 ns normal (1/27 MHz)
 SAV : start of active video timing reference code
 EAV : end of active video timing reference code

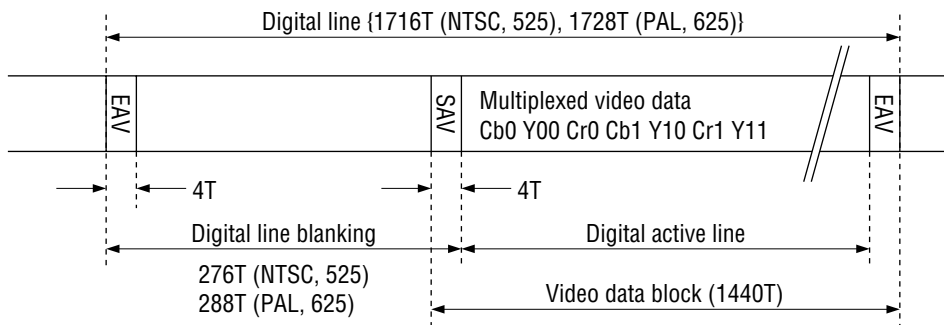

ITU-R BT.656 Output (Data in one line in which video data presents)

During the blanking interval, data is output with the Y value.

Note: Digital line 1716T (NTSC, 525) and 1728T (PAL, 625) are not maintained at the next line. Digital active line 1440T of the line immediately after VVALID falls and the 10th or 11th line after VSYNC_L rises will fluctuate due to pixel compensation. Especially when a non-standard signal is input, the line immediately after VVALID falls will fluctuate largely due to instability of the input signal. Due to phenomena such as an increase in the number of lines for a standard signal and a decrease in the number of lines for a non-standard signal, it may not be possible to guarantee correct EAV and SAV functionality.

Contents of SAV and EAV

Both SAV and EAV consist of 4 words. Their configuration is shown below.

| Word | Bit No. | | | | | | | | F = 0: during field 1 1: during field 2 V = 0: elsewhere 1: during field blanking H = 0: SAV H = 1: EAV P3, P2, P1, P0: Protection bit |
|--------|---------|---|---|---|----|----|----|---------|---|
| | 7 (MSB) | 6 | 5 | 4 | 3 | 2 | 1 | 0 (LSB) | |
| First | 1 | 1 | 1 | 1 | 1 | 1 | 1 | 1 | |
| Second | 0 | 0 | 0 | 0 | 0 | 0 | 0 | 0 | |
| Third | 0 | 0 | 0 | 0 | 0 | 0 | 0 | 0 | |
| Fourth | 1 | F | V | H | P3 | P2 | P1 | P0 | |

The 4th word of SAV and EAV

The relationship between the F, V, H and Protection bits in the 4th word of SAV and EAV is shown below.

| Bit No. | 7 (MSB) | 6 | 5 | 4 | 3 | 2 | 1 | 0 |
|----------|---------|---|---|---|----|----|----|----|
| Function | Fixed 1 | F | V | H | P3 | P2 | P1 | P0 |
| 0 | 1 | 0 | 0 | 0 | 0 | 0 | 0 | 0 |
| 1 | 1 | 0 | 0 | 1 | 1 | 1 | 0 | 1 |
| 2 | 1 | 0 | 1 | 0 | 1 | 0 | 1 | 1 |
| 3 | 1 | 0 | 1 | 1 | 0 | 1 | 1 | 0 |
| 4 | 1 | 1 | 0 | 0 | 0 | 1 | 1 | 1 |
| 5 | 1 | 1 | 0 | 1 | 1 | 0 | 1 | 0 |
| 6 | 1 | 1 | 1 | 0 | 1 | 1 | 0 | 0 |
| 7 | 1 | 1 | 1 | 1 | 0 | 0 | 0 | 1 |

Usually, V = 1 during blanking, however when VBI data is detected and V = 0 is the desired output, set the MRC[3] SAV, EAV V-status of Mode Register C (MRC) to "1".

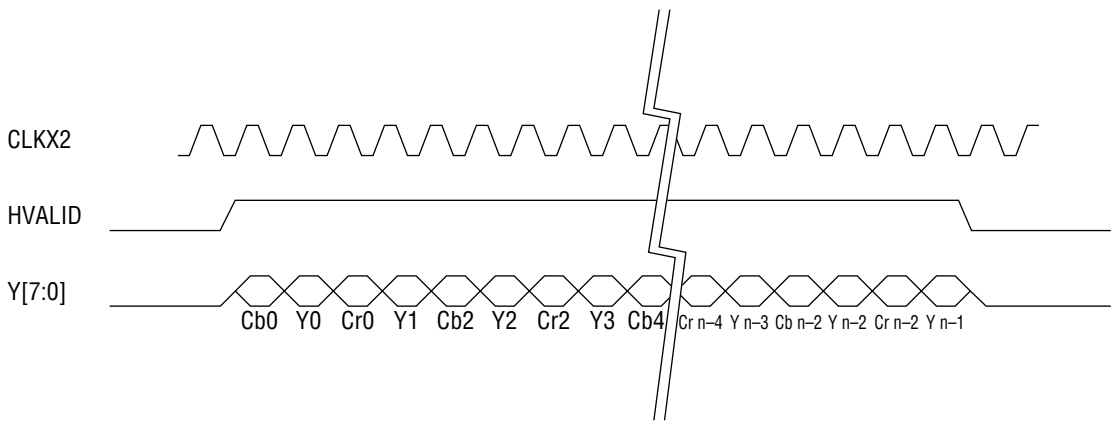

8-bit (YCbCr: 2x clock) Output

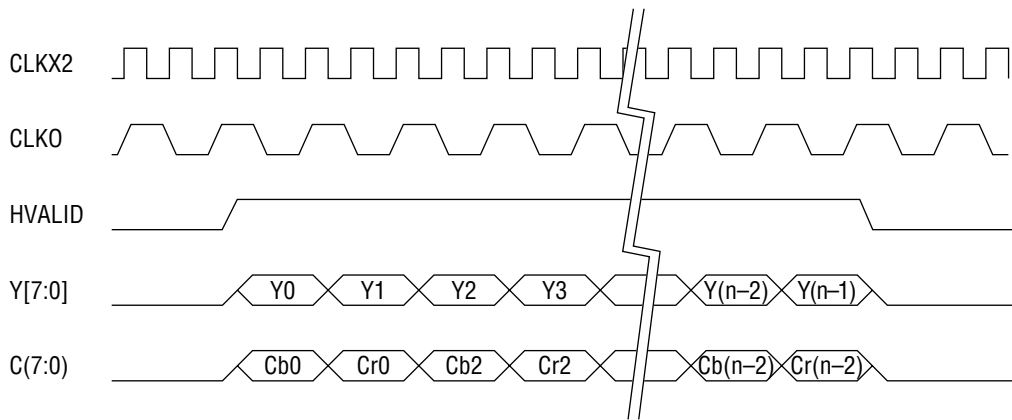

16-bit (Y: 8-bit, CbCr: 8-bit) Output

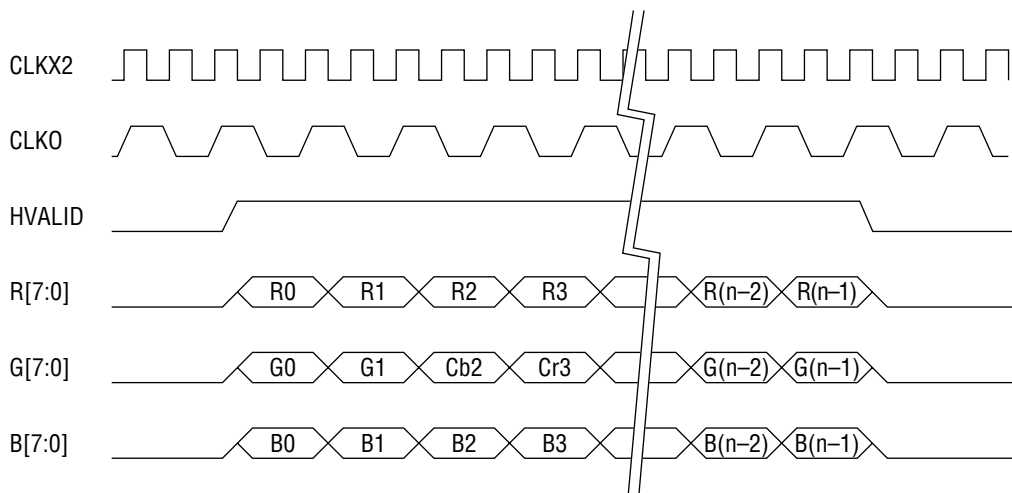

24-bit (R: 8-bit, G: 8-bit, B: 8-bit) Output

• Timing when using external field memory

Field memory timing in the FM-2 mode, using control signals from the decoder

Field memory: MSM518222, 2 units are used (Y and C)

Four memory control signals are supplied from the decoder, M[4]: RSTW, M[5]: RSTR, M[6]: WE., and M[7]: RE.

NTSC Signal (13.5 MHz)

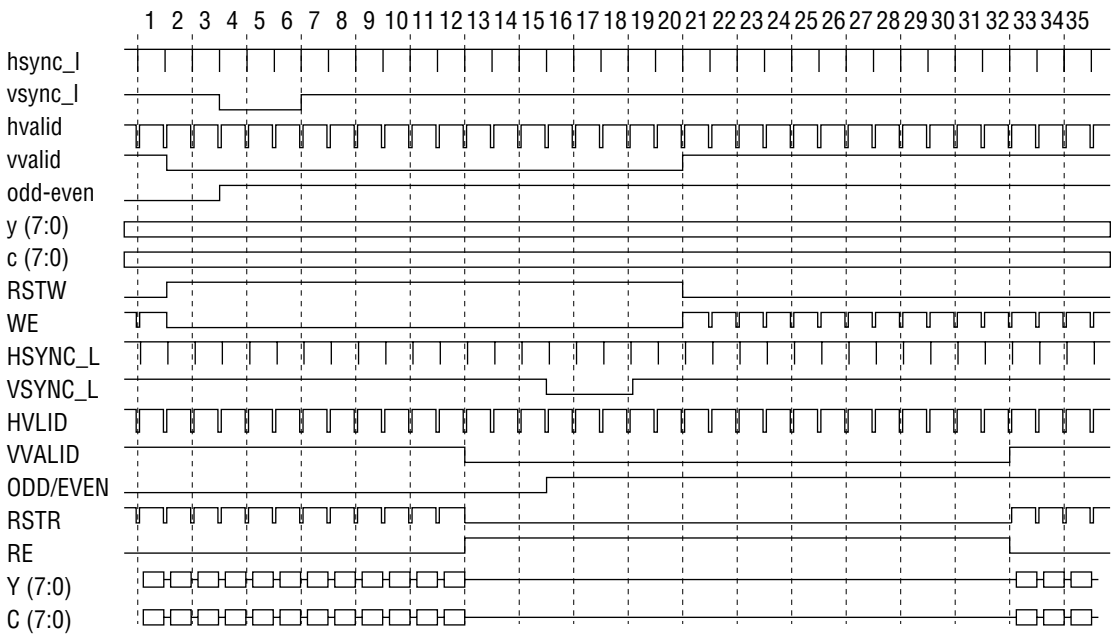

NTSC: ODD Field

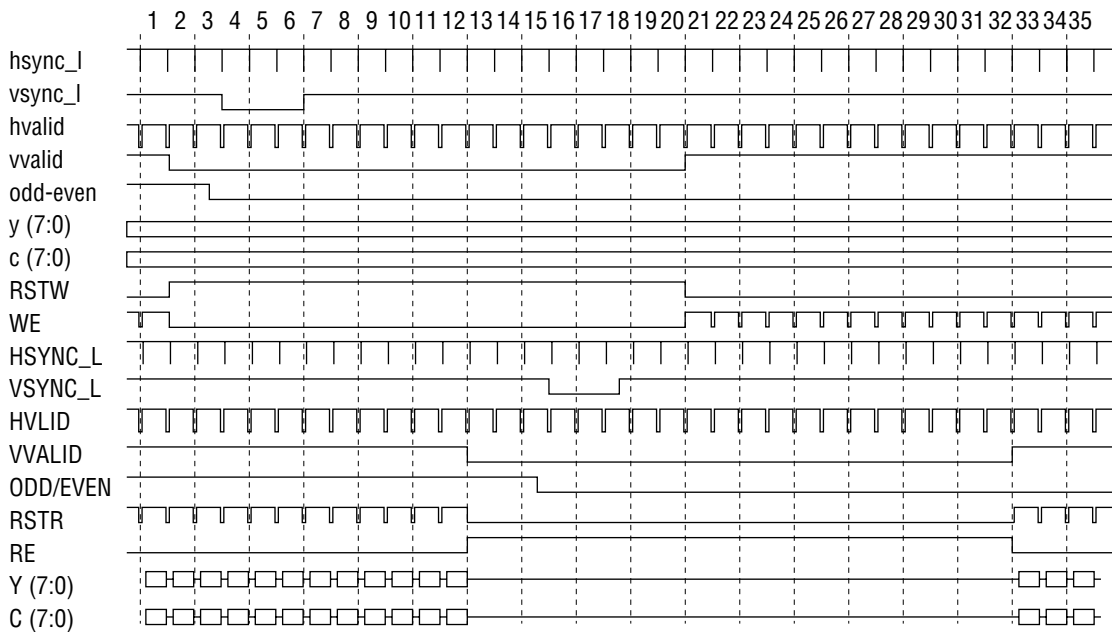

NTSC: EVEN Field

PAL Signal (13.5 MHz)

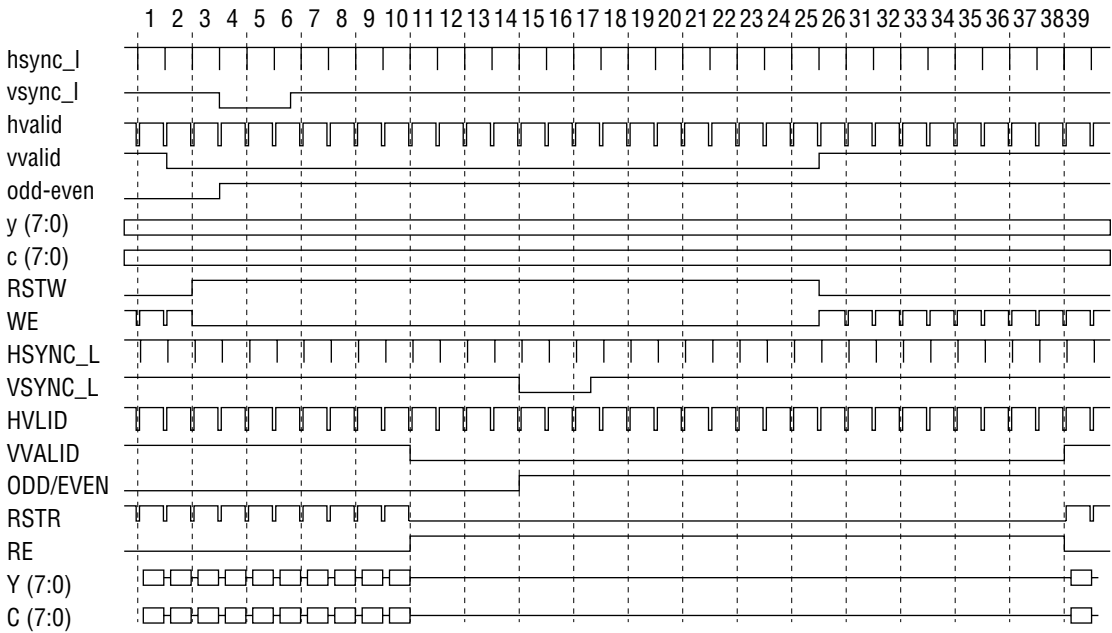

PAL: ODD Field

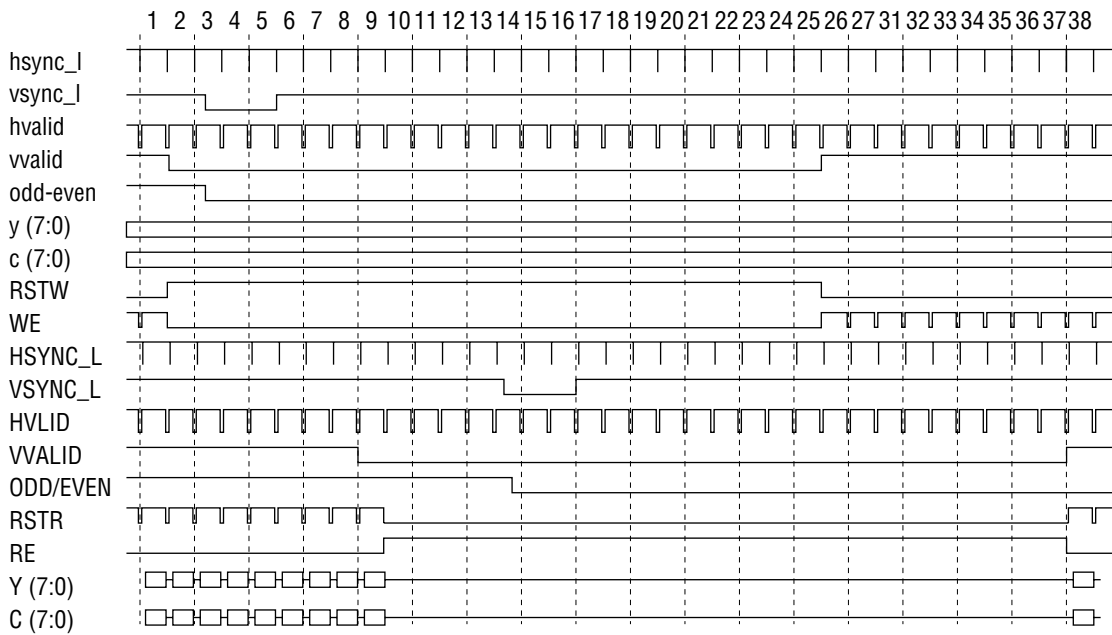

PAL: EVEN Field

Horizontal Synchronization Signal

The horizontal synchronization signal timing is shown below.

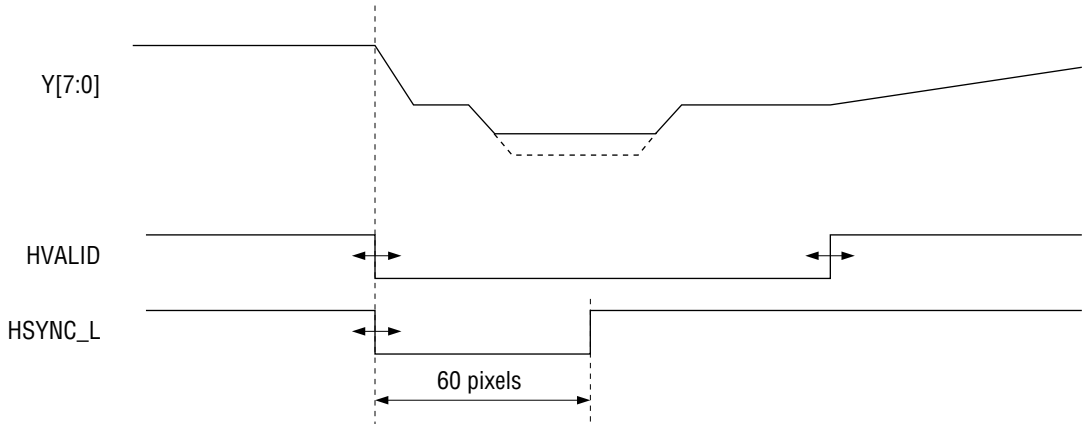

Horizontal Timing

VBI Data Detection (when a Composite signal is input): STATUS1 Timing

VBI data detection results are output from the STATUS1 pin.

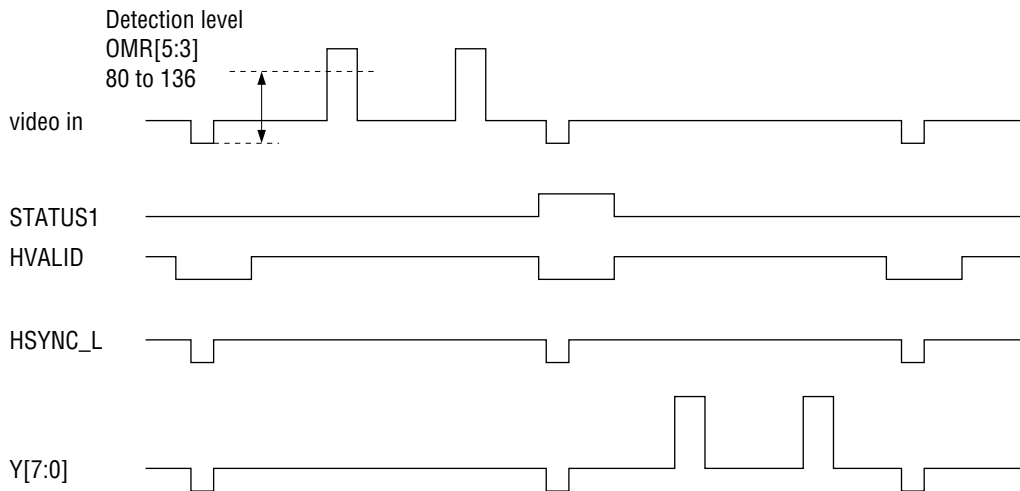

VBI Data Detection (when an S-Video signal is input): STATUS1 Timing

VBI data detection results are output from the STATUS1 pin.

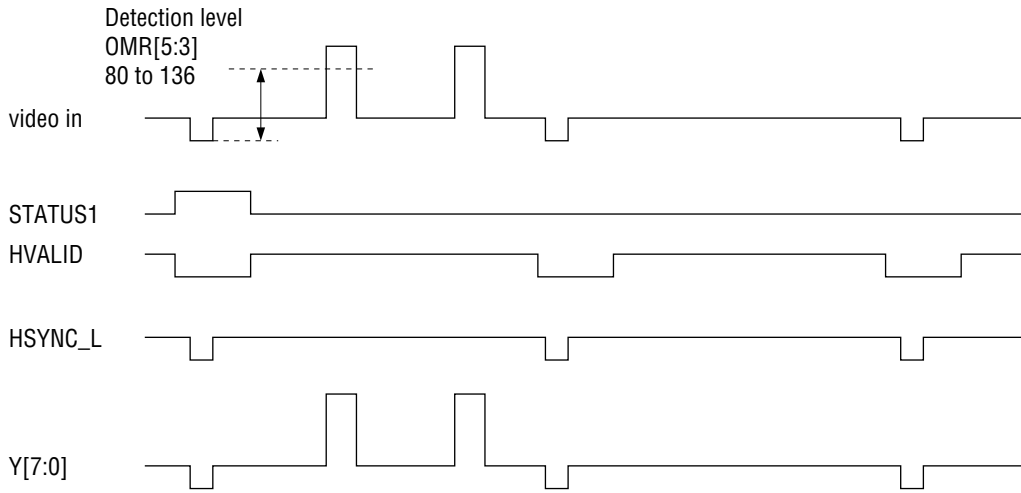

I²C-bus Interface Input and Output Timing

Basic input and output timing of the I²C-bus interface is shown below.

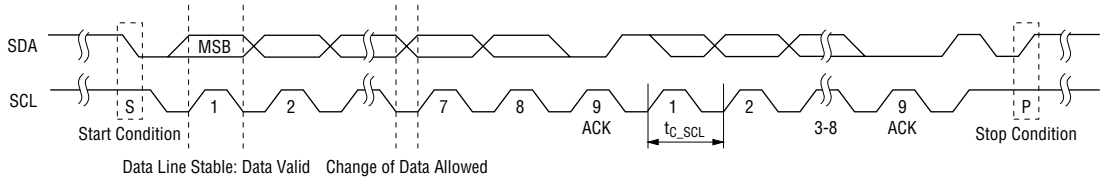

I²C-bus Basic Input/Output Timing

I²C BUS FORMAT

The I²C-bus interface input format is shown below.

| | | | | | | | | | | |
|---|---------------|---|------------|---|--------|---|-------|--------|---|---|
| S | Slave Address | A | Subaddress | A | Data 0 | A | | Data n | A | P |
|---|---------------|---|------------|---|--------|---|-------|--------|---|---|

| Symbol | Description |
|---------------|--|
| S | Start condition |
| Slave Address | Slave address 1000001X, 8th bit is write signal ["0"] or read signal ["1"] |
| A | Acknowledge. Generated by slave |
| Subaddress | Subaddress byte |
| Data n | Data to write to address designated by subaddress. |
| P | Stop condition |

As mentioned above, the write operation can be executed from subaddress to subaddress continuously. When the write operation is executed at subaddresses discontinuously, the Acknowledge and Stop condition formats are input repeatedly after Data 0.

If one of the following matters occurs, the decoder will not return "A" (Acknowledge).

- The slave address does not match.
- A non-existent subaddress is specified.
- The write attribute of a register does not match "X" (read ["1"]/write ["0"] control bit).

The input timing is shown below.

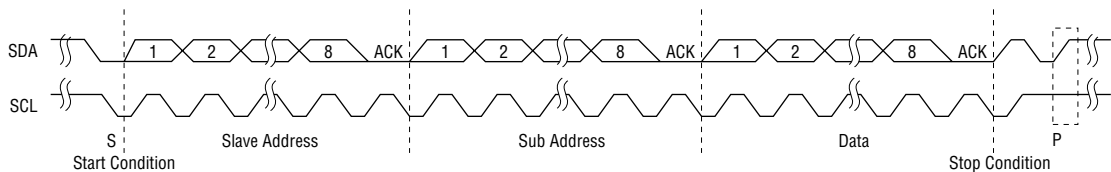

OPERATING MODE SETTING

There are two types of video mode settings.

1. External pin mode: direct setting from dedicated pins
2. Register setting mode: specification by internal register settings

These modes can be switched by the mode register MRA[0].

The reset state (default) is the external pin mode.

The following registers can be set in the external pin mode.

| | | |
|----------|-------------------|--|
| MRA[3:1] | Input signal mode | *00: NTSC ITU-RBT.601 13.5 MHz 001: NTSC Square Pixel 12.27 MHz 010: NTSC 4fsc 14.31818 MHz 100: PAL ITU-RBT.601 13.5 MHz 101: PAL Square Pixel 14.75 MHz |
| MRA[7:6] | Output mode | 00: ITU-R BT.656 (SAV, EAV, blank processing) *01: 8 bit (Y CbCr) HSYNC_L and VSYNC_L used for synchronization 10: ITU-R BT.601 16 bit (8 bit Y, 8 bit CbCr) 11: RGB (8 bit R, 8 bit G, 8 bit B) |

Note: NTSC 4fsc cannot be set externally.

Pin Setting Example

NTSC, 27 MHz (ITU-RBT.601), Composite input, 8-bit (YCbCr) Output

| Pin name | Condition | Notes |
|------------|-----------|---|
| MODE[3] | = low | 0 : ITU-RBT.656 01 : 8-bit (YCbCr) |
| MODE[2] | = high | |
| MODE[1] | = low | 0 : NTSC 1 : PAL |
| MODE[0] | = low | 0 : ITU-RBT.601 1 : Square Pixel |
| CLKSEL | = low | 0 : twice the pixel frequency 1 : pixel frequency |
| PLLSEL | = low | Normally set to a low level |
| INS[2:0] | = low | |
| GAINS[2:0] | = low | |
| TEST[2:0] | = low | |
| SCAN | = low | |
| M[2] | = | : low = 1000001, : high = 1000011 |
| M[1] | = low | Normally set to a low level |
| M[0] | = low | |
| SLEEP | = | 0 : normal operation 1 : sleep operation |

INTERNAL REGISTERS

Register List

| Register Function | Write /Read | Sub-address | Data byte | | | | | | | |
|--|-------------|-------------|-----------|---------|---------|---------|---------|---------|---------|---------|
| | | | D7 | D6 | D5 | D4 | D3 | D2 | D1 | D0 |
| Mode Register A (MRA) | Write | 0 | MRA7 | MRA6 | MRA5 | MRA4 | MRA3 | MRA2 | MRA1 | MRA0 |
| Mode Register B (MRB) | Write | 1 | MRB7 | MRB6 | MRB5 | MRB4 | MRB3 | MRB2 | MRB1 | MRB0 |
| Mode Register C (MRC) | Write | 2 | MRC7 | MRC6 | MRC5 | MRC4 | MRC3 | MRC2 | MRC1 | MRC0 |
| Horizontal Sync Trimmer (HSYT) | Write | 3 | HSYT7 | HSYT6 | HSYT5 | HSYT4 | HSYT3 | HSYT2 | HSYT1 | HSYT0 |
| Sync Threshold level adjust (STHR) | Write | 4 | STHR7 | STHR6 | STHR5 | STHR4 | STHR3 | STHR2 | STHR1 | STHR0 |
| Horizontal Sync Delay (HSDL) | Write | 5 | HSDL7 | HSDL6 | HSDL5 | HSDL4 | HSDL3 | HSDL2 | HSDL1 | HSDL0 |
| Horizontal Valid Trimmer (HVALT) | Write | 6 | HVALID7 | HVALID6 | HVALID5 | HVALID4 | HVALID3 | HVALID2 | HVALID1 | HVALID0 |
| Vertical Valid Trimmer (VVALT) | Write | 7 | VVALID7 | VVALID6 | VVALID5 | VVALID4 | VVALID3 | VVALID2 | VVALID1 | VVALID0 |
| Luminance Control (LUMC) | Write | 8 | LUMC7 | LUMC6 | LUMC5 | LUMC4 | LUMC3 | LUMC2 | LUMC1 | LUMC0 |
| AGC/Pedestal Loop filter Control (AGCLF) | Write | 9 | AGCLF7 | AGCLF6 | AGCLF5 | AGCLF4 | AGCLF3 | AGCLF2 | AGCLF1 | AGCLF0 |
| Sync separation level (SSEPL) | Write | A | SSEPL7 | SSEPL6 | SSEPL5 | SSEPL4 | SSEPL3 | SSEPL2 | SSEPL1 | SSEPL0 |
| Chrominance Control (CHRC) | Write | B | CHRC7 | CHRC6 | CHRC5 | CHRC4 | CHRC3 | CHRC2 | CHRC1 | CHRC0 |
| ACC Loop filter Control (ACCLF) | Write | C | ACCLF7 | ACCLF6 | ACCLF5 | ACCLF4 | ACCLF3 | ACCLF2 | ACCLF1 | ACCLF0 |
| Hue Control (HUE) | Write | D | HUE7 | HUE6 | HUE5 | HUE4 | HUE3 | HUE2 | HUE1 | HUE0 |
| Output phase Control for Data Y (OPCY) | Write | E | OPCY7 | OPCY6 | OPCY5 | OPCY4 | OPCY3 | OPCY2 | OPCY1 | OPCY0 |
| Output phase Control for Data C (OPCC) | Write | F | OPCC7 | OPCC6 | OPCC5 | OPCC4 | OPCC3 | OPCC2 | OPCC1 | OPCC0 |
| Optional Mode Register (OMR) | Write | 10 | OMR7 | OMR6 | OMR5 | OMR4 | OMR3 | OMR2 | OMR1 | OMR0 |
| ADC register (ADC1) | Write | 11 | ADC17 | ADC16 | ADC15 | ADC14 | ADC13 | ADC12 | ADC11 | ADC10 |
| ADC register (ADC2) | Write | 12 | ADC27 | ADC26 | ADC25 | ADC24 | ADC23 | ADC22 | ADC21 | ADC20 |
| ADC register (ADC3) | Write | 13 | ADC37 | ADC36 | ADC35 | ADC34 | ADC33 | ADC32 | ADC31 | ADC30 |
| 0 level detect register (ZLD) | Write | 14 | ZLD7 | ZLD6 | ZLD5 | ZLD4 | ZLD3 | ZLD2 | ZLD1 | ZLD0 |
| Status register (STATUS) | Read | 20 | STATUS7 | STATUS6 | STATUS5 | STATUS4 | STATUS3 | STATUS2 | STATUS1 | STATUS0 |

Register Parameters

Registers controlled from the I²C-bus are listed below.

An asterisk (*) indicates that the register setting value is the default value.

| | | |
|-----------------------|-----------------------|---|
| Mode Register A (MRA) | Write only | <address: \$00> |
| MRA[7:6] | Video output mode | 00: ITU-R BT.656 (SAV, EAV, blank processing) *01: Y,C 8 bits (SAV, EAV, without blank processing) 10: Y,C 16 bits 11: RGB 24 bits |
| MRA[5] | Chroma format | *0: Offset binary 1: 2's Complement |
| MRA[4] | Video input model | *0: Composite video input 1: S-video input |
| MRA[3:1] | Video Input mode2 | *000: NTSC ITU-R BT.601 13.5 MHz 001: NTSC Square Pixel 12.27 MHz 010: NTSC 4fsc 14.31818 MHz 100: PAL ITU-R BT.601 13.5 MHz 101: PAL Square Pixel 14.75 MHz |
| MRA[0] | Disable MODE[3:0] pin | *0: External pin mode 1: Register mode |
| Mode Register B (MRB) | Write only | <address: \$01> |
| MRB[7:6] | Synchronization mode | *00: FIFO-1 (use internal memory) 01: FIFO-2 (use internal memory) 10: FM-1 (use external memory, external control) 11: FM-2 (use external memory, control signals supplied from M[7:4]) |
| MRB[5] | Color killer mode | *0: Auto color killer (Chrominance signal level is set to "0" if the color burst level is below the specified value.) *1: Forced color killer (Chrominance signal level is forced to "0".) |
| MRB[4] | Blue Back | 0: OFF (Video signal is demodulated and output regardless of synchronization detection.) *1: AUTO (Blue Back is output when synchronization is not detected.) |
| MRB[3:2] | Clamp mode | *00: Analog Clamp (HSY = 1) 01: Analog, HSY hybrid clamp 10: HSY clamp 11: HSY = 0 |
| MRB[1:0] | Y/C separation mode | *00: Adaptive comb filter (Correlation of 3 lines is monitored and operating mode is selected.) 01: Non-adaptive comb filter (Operating mode is always fixed.) 10: Use trap filter. (Comb filter is not used.) 11: Undefined |

| | | |
|-------|--------------------------|-----------------------------------|
| Note: | Adaptive comb filter | 2/3-line comb filter for NTSC |
| | | Comb filter/trap filter for PAL |
| | Non-adaptive comb filter | 3-line comb filter for NTSC |
| | | 2-line cosine comb filter for PAL |

Mode Register C (MRC) Write only <address: \$02>

| | | |
|----------|---|--|
| MRC[7] | NTSC/PAL Auto select | 0: Fix *1: Auto |
| MRC[6] | Sub Pixel Alignment | *0: Use pixel position compensating circuit. 1: Do not use pixel position compensating circuit. |
| MRC[5] | Pixel Sampling Rate | *0: (4:2:2) 1: (4:1:1) |
| MRC[4] | Data-pass control | *0: Use DECIMATOR at 2x sampling 1: Do not use DECIMATOR |
| Note: | This register is valid when a 2x clock (27 MHz) is input. | |
| MRC[3] | SAV, EAV V-status | *0: During blanking, V = 1 1: During blanking, while VBI data is not detected, V = 1 |
| MRC[2] | RGB output level | *0: 0 to 255 1: 16 to 235 |
| MRC[1:0] | Undefined | Set to 0 |

Horizontal Sync Trimmer (HSYT) Write only <address: \$03>

| | | |
|-----------|--------------------------------|--|
| HSYT[7:4] | HSY start trimmer (× 8 pixels) | \$C to \$B (*\$0): -4 to +11 (-32 to +88 pixels) |
| HSYT[3:0] | HSY stop trimmer (× 8 pixels) | \$C to \$B (*\$0): -4 to +11 (-32 to +88 pixels) |

Sync. Threshold level adjust (STHR) Write only <address: \$04>

| | | |
|-----------|-------------|--------------------------------|
| STHR[7:0] | Sync. depth | \$00 to \$FF (*\$1E): 0 to 255 |
|-----------|-------------|--------------------------------|

Horizontal Sync Delay (HSDL) Write only <address: \$05>

| | | |
|-----------|-----------------------------------|--|
| HSDL[7:0] | HSYNC_L delay trimmer (× 1 pixel) | \$80 to \$7F (*\$00): -128 to +127 (-128 to +127 pixels) |
|-----------|-----------------------------------|--|

Note: In the internal sync separation (PLLSEL: Low) mode, the HSYNC_L sync signal output position is adjusted.
In the external sync separation (PLLSEL: High) mode, the phase shift of the H-Sync input and video signal input is adjusted.

Horizontal Valid Trimmer (HVALT) Write only <address: \$06>

| | | |
|------------|-----------------------------------|---|
| HVALT[7:4] | HVALID start trimmer (× 2 pixels) | \$8 to \$7 (*\$0): -8 to +7 (-16 to +14 pixels) |
| HVALT[3:0] | HVALID stop trimmer (× 2 pixels) | \$8 to \$7 (*\$0): -8 to +7 (-16 to +14 pixels) |

Vertical Valid Trimmer (VVALT) Write only <address: \$07>

VVALT[7:4] VVALID start trimmer (× 1 line) \$8 to \$7 (*\$0): -8 to +7
 VVALT[3:0] VVALID stop trimmer (× 1 line) \$8 to \$7 (*\$0): -8 to +7

Luminance Control (LUMC) Write only <address: \$08>

LUMC[7] Output level limiter *0: OFF
 1: ON
 Note: Control range while limiter is ON: 16...235
 LUMC[6] Use of Pre-filter *0: Do not use prefilter
 1: Use prefilter
 LUMC[5:4] Aperture bandpass select *00: range0 (middle)
 01: range1
 10: range2
 11: range3 (high)
 LUMC[3:2] Coring range select *00: coring off
 01: +/-4LSB
 10: +/-5LSB
 11: +/-7LSB
 LUMC[1:0] Aperture filter weighting factor
 *00: 0.00
 01: 0.25
 10: 0.75
 11: 1.50

AGC/Pedestal Loop filter control (AGCLF) Write only <address: \$09>

AGCLF[7:6] AGC loop filter time constant
 00: slow
 *01: medium
 10: fast
 11: MGC mode
 AGCLF[5:0] AGC reference level \$20 to \$1F (*\$00): -32 to +31

Sync separation level (SSEPL) Write only <address: \$0A>

SSEPL[7] Pedestal Clamp on/off *0: Do not use pedestal clamp
 1: Use pedestal clamp (AGC stops operating)
 SSEPL[6:0] Sync. separation level \$40 to \$3F (*\$00): -64 to +63

Chrominance Control (CHRC) Write only <address: \$0B>

CHRC[7:4] Undefined Set 0
 CHRC[3] C-Output level limiter *0: OFF
 1: ON
 Note: Control range while limiter is ON: 16...224

CHRC[2] Chroma bandpass filter 0: OFF
 *1: ON
 CHRC[1:0] Color kill threshold factor 00: 0.500 color burst level
 *01: 0.250 color burst level
 10: 0.125 color burst level
 11: Color killer off

ACC Loop filter control (ACCLF)

Write only <address: \$0C>

ACCLF[7] Undefined Set 0
 ACCLF[6:5] ACC loop filter time constant
 00: slow
 *01: medium
 10: fast
 11: MCC mode
 ACCLF[4:0] ACC reference level \$10 to \$0F (*\$00): -16 to +15

Hue control (HUE)

Write only <address: \$0D>

HUE[7:0] Hue control \$80 to \$7F (*\$00): -180 to +178.6 degrees

Output phase control for data Y (OPCY)

Write only <address: \$0E>

OPCY[7:2] Undefined Set 0
 OPCY[1:0] Output phase control for data Y
 *00: normal
 01: forward 1 clock
 10: backward 2 clock
 11: backward 1 clock

Output phase control for data C (OPCC)

Write only <address: \$0F>

OPCC[7:2] Undefined Set 0
 OPCC[1:0] Output phase control for data C
 *00: normal
 01: forward 1 clock
 10: backward 2 clock
 11: backward 1 clock

Optional Mode Register (OMR)

Write only <address: \$10>

OMR[7] HSY output timing select *0: Use A/D clamp position adjust circuit
 1: Do not use A/D clamp position adjust circuit

| | | |
|----------|--|---|
| OMR[6] | VSYNC output timing select | *0: VSYNC_L is synchronized to HSYNC_L and then output 1: VSYNC_L is output when a VSYNC input signal is detected. |
| OMR[5:3] | Multiplex signal detection level (VBID etc.) | 000: 80 001: 88 *010: 96 011: 104 100: 112 101: 120 110: 128 111: 136 |
| OMR[2] | Hi-Z Output in SLEE MODE | *0: Active 1: Hi-Z |
| OMR[1] | Status2 output mode | *0: NTSC/PAL identification 1: HLOCK sync detection |
| OMR[0] | Status3 output mode | *0: TV/VCR identification 1: CSYNC |

ADC register 1 (ADC1) Write only <address: \$11>

| | | |
|-----------|----------------------|--|
| ADC1[7] | Video amp select | *0: Use 1: Do not use |
| ADC1[6] | Comparator select | *0: Use 1: Do not use |
| ADC1[5:4] | Clamp current select | *00: 1.0 01: 1.5 10: Undefined 11: 2.0 |
| ADC1[2:0] | ADC input select | *000: ADI-VIN1 (composite) 001: ADI-VIN2 (composite) 010: ADI-VIN3 (composite) 011: ADI-VIN4 (composite) 100: ADI-VIN5 (composite) 101: ADI-VIN1 (Y), AD2-VIN5 (C) 110: ADI-VIN2 (Y), AD2-VIN6 (C) 111: Prohibited setting (ADC enters sleep state) |

ADC register 2 (ADC2) Write only <address: \$12>

| | | |
|-----------|------------------------------|--|
| ADC2[7] | ADC gain control mode select | 0: manual *1: auto |
| ADC2[6:4] | ADC gain manual select | 000: 1.00 *001: 1.35 010: 1.75 011: 2.30 100: 3.00 |

101: 3.80
 110: 5.00
 111: 2.05
 ADC2[3] ADC initialize condition gain select
 0: not initialize
 *1: initialize
 ADC2[1:0] ADC gain control and stage select
 00: 2nd change end
 01: 3rd change end
 *10: 3rd change loop

ADC register 3 (ADC3) Write only <address: \$13>

ADC3[7] Undefined Set 0
 ADC3[6:4] ADC gain control margin level select
 000: 10 mV
 001: 20 mV
 *010: 40 mV
 011: 80 mV
 100: 160 mV
 ADC3[2:0] ADC gain control line select
 000: 1 line
 001: 2 lines
 *010: 4 lines
 011: 8 lines
 100: 16 lines

0 level detect register (ZLD) Write only <address: \$14>

ZLD[7:3] Undefined Set 0
 ZLD[2:0] 0 level detect width (× 8 pixel)
 000: Undefined
 001: 8 pixels
 *010: 16 pixels
 011: 24 pixels
 100: 32 pixels
 101: 40 pixels
 110: 48 pixels
 111: 56 pixels

Status register (STATUS) Read only <address: \$20>

STATUS[7:5] Undefined
 STATUS[4] VBI interval multiplex signal detection 0: Non-detection, 1: Detection
 STATUS[3] HLOCK sync detection 0: Non-detection, 1: Detection
 STATUS[2] NTSC/PAL identification 0: NTSC, 1: PAL
 STATUS[1] TV1/TV2 identification Mode Register B (bit 6)
 0: TV1, 1: TV2
 STATUS[0] FTFO overflow detection 0: Non-detection, 1: Detection

Relationship between Register Setting Value and Adjusted Value

Horizontal Sync Trimmer

Position adjustment of sync chip clamp timing signal

HSYT [7:4] :Adjusting the starting position

| | | | | | | | | | | | | | | | | |
|-----------------------------|-----|-----|-----|----|---|----|-----|-----|-----|-----|-----|-----|-----|-----|-----|-----|
| Register Setting Value (0x) | C | D | E | F | 0 | 1 | 2 | 3 | 4 | 5 | 6 | 7 | 8 | 9 | A | B |
| Adjusted Value (Pixel) | -32 | -24 | -16 | -8 | 0 | +8 | +16 | +24 | +32 | +40 | +48 | +56 | +64 | +72 | +80 | +88 |

HSYT [3:0] :Adjusting the end position

| | | | | | | | | | | | | | | | | |
|-----------------------------|-----|-----|-----|----|---|----|-----|-----|-----|-----|-----|-----|-----|-----|-----|-----|
| Register Setting Value (0x) | C | D | E | F | 0 | 1 | 2 | 3 | 4 | 5 | 6 | 7 | 8 | 9 | A | B |
| Adjusted Value (Pixel) | -32 | -24 | -16 | -8 | 0 | +8 | +16 | +24 | +32 | +40 | +48 | +56 | +64 | +72 | +80 | +88 |

Horizontal Sync Delay

Adjustment of the starting position of horizontal sync signal

HSDL [7:0]

| | | MSB[7 : 4] | | | | | | | | | | | | | | | |
|----------------|---|------------|------|-----|-----|-----|-----|-----|-----|-----|-----|-----|-----|-----|-----|------|------|
| | | 8 | 9 | A | B | C | D | E | F | 0 | 1 | 2 | 3 | 4 | 5 | 6 | 7 |
| LSB [3 : 0] | 0 | -128 | -112 | -96 | -80 | -64 | -48 | -32 | -16 | 0 | +16 | +32 | +48 | +64 | +80 | +96 | +112 |
| | 1 | -127 | -111 | -95 | -79 | -63 | -47 | -31 | -15 | +1 | +17 | +33 | +49 | +65 | +81 | +97 | +113 |
| | 2 | -126 | -110 | -94 | -78 | -62 | -46 | -30 | -14 | +2 | +18 | +34 | +50 | +66 | +82 | +98 | +114 |
| | 3 | -125 | -109 | -93 | -77 | -61 | -45 | -29 | -13 | +3 | +19 | +35 | +51 | +67 | +83 | +99 | +115 |
| | 4 | -124 | -108 | -92 | -76 | -60 | -44 | -28 | -12 | +4 | +20 | +36 | +52 | +68 | +84 | +100 | +116 |
| | 5 | -123 | -107 | -91 | -75 | -59 | -43 | -27 | -11 | +5 | +21 | +37 | +53 | +69 | +85 | +101 | +117 |
| | 6 | -122 | -106 | -90 | -74 | -58 | -42 | -26 | -10 | +6 | +22 | +38 | +54 | +70 | +86 | +102 | +118 |
| | 7 | -121 | -105 | -89 | -73 | -57 | -41 | -25 | -9 | +7 | +23 | +39 | +55 | +71 | +87 | +103 | +119 |
| | 8 | -120 | -104 | -88 | -72 | -56 | -40 | -24 | -8 | +8 | +24 | +40 | +56 | +72 | +88 | +104 | +120 |
| | 9 | -119 | -103 | -87 | -71 | -55 | -39 | -23 | -7 | +9 | +25 | +41 | +57 | +73 | +89 | +105 | +121 |
| | A | -118 | -102 | -86 | -70 | -54 | -38 | -22 | -6 | +10 | +26 | +42 | +58 | +74 | +90 | +106 | +122 |
| | B | -117 | -101 | -85 | -69 | -53 | -37 | -21 | -5 | +11 | +27 | +43 | +59 | +75 | +91 | +107 | +123 |
| | C | -116 | -100 | -84 | -68 | -52 | -36 | -20 | -4 | +12 | +28 | +44 | +60 | +76 | +92 | +108 | +124 |
| | D | -115 | -99 | -83 | -67 | -51 | -35 | -19 | -3 | +13 | +29 | +45 | +61 | +77 | +93 | +109 | +125 |
| | E | -114 | -98 | -82 | -66 | -50 | -34 | -18 | -2 | +14 | +30 | +46 | +62 | +78 | +94 | +110 | +126 |
| | F | -113 | -97 | -81 | -65 | -49 | -33 | -17 | -1 | +15 | +31 | +47 | +63 | +79 | +95 | +111 | +127 |

Horizontal Valid Trimmer

Position adjustment of horizontal valid pixel timing signal

HVALT [7:4] :Adjusting the starting position

| | | | | | | | | | | | | | | | | |
|-----------------------------|-----|-----|-----|-----|----|----|----|----|---|----|----|----|----|-----|-----|-----|
| Register Setting Value (0x) | 8 | 9 | A | B | C | D | E | F | 0 | 1 | 2 | 3 | 4 | 5 | 6 | 7 |
| Adjusted Value (Pixel) | -16 | -14 | -12 | -10 | -8 | -6 | -2 | -1 | 0 | +2 | +4 | +6 | +8 | +10 | +12 | +14 |

HVALT [3:0] :Adjusting the end position

| | | | | | | | | | | | | | | | | |
|-----------------------------|-----|-----|-----|-----|----|----|----|----|---|----|----|----|----|-----|-----|-----|
| Register Setting Value (0x) | 8 | 9 | A | B | C | D | E | F | 0 | 1 | 2 | 3 | 4 | 5 | 6 | 7 |
| Adjusted Value (Pixel) | -16 | -14 | -12 | -10 | -8 | -6 | -4 | -2 | 0 | +2 | +4 | +6 | +8 | +10 | +12 | +14 |

Vertical Valid Trimmer

Position adjustment of vertical valid line timing signal

VVALT [7:4] :Adjusting the starting position

| | | | | | | | | | | | | | | | | |
|-----------------------------|----|----|----|----|----|----|----|----|---|----|----|----|----|----|----|----|
| Register Setting Value (0x) | 8 | 9 | A | B | C | D | E | F | 0 | 1 | 2 | 3 | 4 | 5 | 6 | 7 |
| Adjusted Value (Line) | -8 | -7 | -6 | -5 | -4 | -3 | -2 | -1 | 0 | +1 | +2 | +3 | +4 | +5 | +6 | +7 |

VVALT [3:0] :Adjusting the end position

| | | | | | | | | | | | | | | | | |
|-----------------------------|----|----|----|----|----|----|----|----|---|----|----|----|----|----|----|----|
| Register Setting Value (0x) | 8 | 9 | A | B | C | D | E | F | 0 | 1 | 2 | 3 | 4 | 5 | 6 | 7 |
| Adjusted Value (Line) | -8 | -7 | -6 | -5 | -4 | -3 | -2 | -1 | 0 | +1 | +2 | +3 | +4 | +5 | +6 | +7 |

AGC Loop filter control

AGCLF [5:0] :Adjusting sync level

| Register Setting Value (0x) | MSB [5 : 4] | | | | |
|-----------------------------|-------------|-----|-----|-----|-----|
| | 2 | 3 | 0 | 1 | |
| LSB [3 : 0] | 0 | -32 | -16 | 0 | +16 |
| | 1 | -31 | -15 | +1 | +17 |
| | 2 | -30 | -14 | +2 | +18 |
| | 3 | -29 | -13 | +3 | +19 |
| | 4 | -28 | -12 | +4 | +20 |
| | 5 | -27 | -11 | +5 | +21 |
| | 6 | -26 | -10 | +6 | +22 |
| | 7 | -25 | -9 | +7 | +23 |
| | 8 | -24 | -8 | +8 | +24 |
| | 9 | -23 | -7 | +9 | +25 |
| | A | -22 | -6 | +10 | +26 |
| | B | -21 | -5 | +11 | +27 |
| | C | -20 | -4 | +12 | +28 |
| | D | -19 | -3 | +13 | +29 |
| | E | -18 | -2 | +14 | +30 |
| | F | -17 | -1 | +15 | +31 |

Sync separation level

SSEPL [6:0] :Adjusting the blanking level

| Register Setting Value (0x) | MSB [6 : 4] | | | | | | | | |
|-----------------------------|-------------|-----|-----|-----|-----|-----|-----|-----|-----|
| | 4 | 5 | 6 | 7 | 0 | 1 | 2 | 3 | |
| LSB [3 : 0] | 0 | -64 | -48 | -32 | -16 | 0 | +16 | +32 | +48 |
| | 1 | -63 | -47 | -31 | -15 | +1 | +17 | +33 | +49 |
| | 2 | -62 | -46 | -30 | -14 | +2 | +18 | +34 | +50 |
| | 3 | -61 | -45 | -29 | -13 | +3 | +19 | +35 | +51 |
| | 4 | -60 | -44 | -28 | -12 | +4 | +20 | +36 | +52 |
| | 5 | -59 | -43 | -27 | -11 | +5 | +21 | +37 | +53 |
| | 6 | -58 | -42 | -26 | -10 | +6 | +22 | +38 | +54 |
| | 7 | -57 | -41 | -25 | -9 | +7 | +23 | +39 | +55 |
| | 8 | -56 | -40 | -24 | -8 | +8 | +24 | +40 | +56 |
| | 9 | -55 | -39 | -23 | -7 | +9 | +25 | +41 | +57 |
| | A | -54 | -38 | -22 | -6 | +10 | +26 | +42 | +58 |
| | B | -53 | -37 | -21 | -5 | +11 | +27 | +43 | +59 |
| | C | -52 | -36 | -20 | -4 | +12 | +28 | +44 | +60 |
| | D | -51 | -35 | -19 | -3 | +13 | +29 | +45 | +61 |
| | E | -50 | -34 | -18 | -2 | +14 | +30 | +46 | +62 |
| | F | -49 | -33 | -17 | -1 | +15 | +31 | +47 | +63 |

ACC Loop filter control

ACCLF [4:0] :Adjusting the color burst level

| Register Setting Value (0x) | MSB [4] | | |
|-----------------------------|---------|-----|-----|
| | 1 | 0 | |
| LSB [3 : 0] | 0 | -16 | 0 |
| | 1 | -15 | +1 |
| | 2 | -14 | +2 |
| | 3 | -13 | +3 |
| | 4 | -12 | +4 |
| | 5 | -11 | +5 |
| | 6 | -10 | +6 |
| | 7 | -9 | +7 |
| | 8 | -8 | +8 |
| | 9 | -7 | +9 |
| | A | -6 | +10 |
| | B | -5 | +11 |
| | C | -4 | +12 |
| | D | -3 | +13 |
| | E | -2 | +14 |
| | F | -1 | +15 |

Hue control
Adjustment of color subcarrier phase

HUE [7:0]

| Register Setting Value (0x) | MSB [7 : 4] | | | | | | | | | | | | | | | | |
|-----------------------------|-------------|--------|--------|--------|--------|-------|-------|-------|-------|-------|-------|-------|-------|--------|--------|--------|--------|
| | 8 | 9 | A | B | C | D | E | F | 0 | 1 | 2 | 3 | 4 | 5 | 6 | 7 | |
| LSB [3 : 0] | 0 | -180.0 | -157.5 | -135.0 | -112.5 | -90.0 | -67.5 | -45.0 | -22.5 | +0.0 | +22.5 | +45.0 | +67.5 | +90.0 | +112.5 | +135.0 | +157.5 |
| | 1 | -178.6 | -156.1 | -133.6 | -111.1 | -88.6 | -66.1 | -43.6 | -21.1 | +1.4 | +23.9 | +46.4 | +68.9 | +91.4 | +113.9 | +136.4 | +158.9 |
| | 2 | -177.2 | -154.7 | -132.2 | -109.7 | -87.2 | -64.7 | -42.2 | -19.7 | +2.8 | +25.3 | +47.8 | +70.3 | +92.8 | +115.3 | +137.8 | +160.3 |
| | 3 | -175.8 | -153.3 | -130.8 | -108.3 | -85.8 | -63.3 | -40.8 | -18.3 | +4.2 | +26.7 | +49.2 | +71.7 | +94.2 | +116.7 | +139.2 | +161.7 |
| | 4 | -174.4 | -151.9 | -129.4 | -106.9 | -84.4 | -61.9 | -39.4 | -16.9 | +5.6 | +28.1 | +50.6 | +73.1 | +95.6 | +118.1 | +140.6 | +163.1 |
| | 5 | -173.0 | -150.5 | -128.0 | -105.5 | -83.0 | -60.5 | -38.0 | -15.5 | +7.0 | +29.5 | +52.0 | +74.5 | +97.0 | +119.5 | +142.0 | +164.5 |
| | 6 | -171.6 | -149.1 | -126.6 | -104.1 | -81.6 | -59.1 | -36.6 | -14.1 | +8.4 | +30.9 | +53.4 | +75.9 | +98.4 | +120.9 | +143.4 | +165.9 |
| | 7 | -170.2 | -147.7 | -125.2 | -102.7 | -80.2 | -57.7 | -35.2 | -12.7 | +9.8 | +32.3 | +54.8 | +77.3 | +99.8 | +122.3 | +144.8 | +167.3 |
| | 8 | -168.8 | -146.3 | -123.8 | -101.3 | -78.8 | -56.3 | -33.8 | -11.3 | +11.3 | +33.8 | +56.3 | +78.8 | +101.3 | +123.8 | +146.3 | +168.8 |
| | 9 | -167.3 | -144.8 | -122.3 | -99.8 | -77.3 | -54.8 | -32.3 | -9.8 | +12.7 | +35.2 | +57.7 | +80.2 | +102.7 | +125.2 | +147.7 | +170.2 |
| | A | -165.9 | -143.4 | -120.9 | -98.4 | -75.9 | -53.4 | -30.9 | -8.4 | +14.1 | +36.6 | +59.1 | +81.6 | +104.1 | +126.6 | +149.1 | +171.6 |
| | B | -164.5 | -142.0 | -119.5 | -97.0 | -74.5 | -52.0 | -29.5 | -7.0 | +15.5 | +38.0 | +60.5 | +83.0 | +105.5 | +128.0 | +150.5 | +173.0 |
| | C | -163.1 | -140.6 | -118.1 | -95.6 | -73.1 | -50.6 | -28.1 | -5.6 | +16.9 | +39.4 | +61.9 | +84.4 | +106.9 | +129.4 | +151.9 | +174.4 |
| | D | -161.7 | -139.2 | -116.7 | -94.2 | -71.7 | -49.2 | -26.7 | -4.2 | +18.3 | +40.8 | +63.3 | +85.8 | +108.3 | +130.8 | +153.3 | +175.8 |
| | E | -160.3 | -137.8 | -115.3 | -92.8 | -70.3 | -47.8 | -25.3 | -2.8 | +19.7 | +42.2 | +64.7 | +87.2 | +109.7 | +132.2 | +154.7 | +177.2 |
| | F | -158.9 | -136.4 | -113.9 | -91.4 | -68.9 | -46.4 | -23.9 | -1.4 | +21.1 | +43.6 | +66.1 | +88.6 | +111.1 | +133.6 | +156.1 | +178.6 |

Filter Characteristics

Band Pass Filter (NTSC ITU-R601)

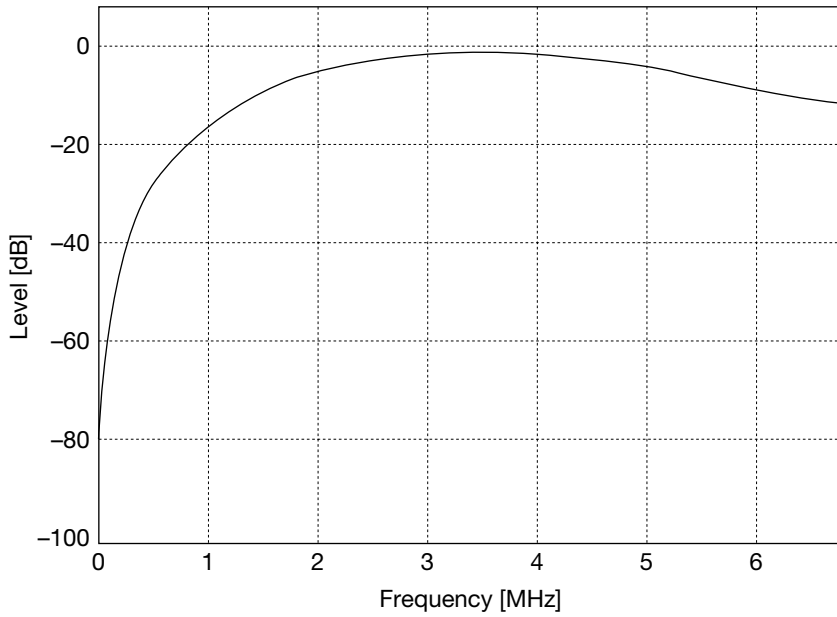

Band Pass Filter (PAL ITU-R601)

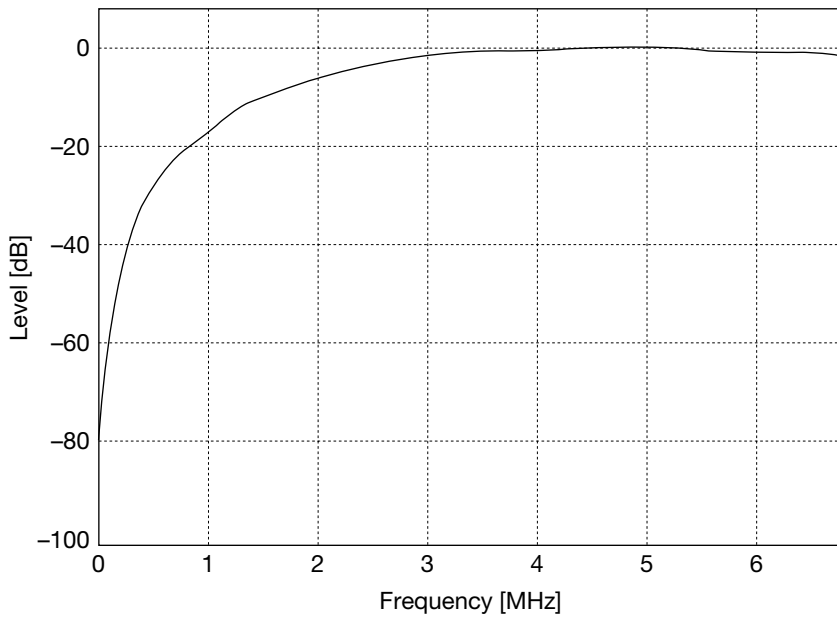

Trap Filter (NTSC ITU-R601)

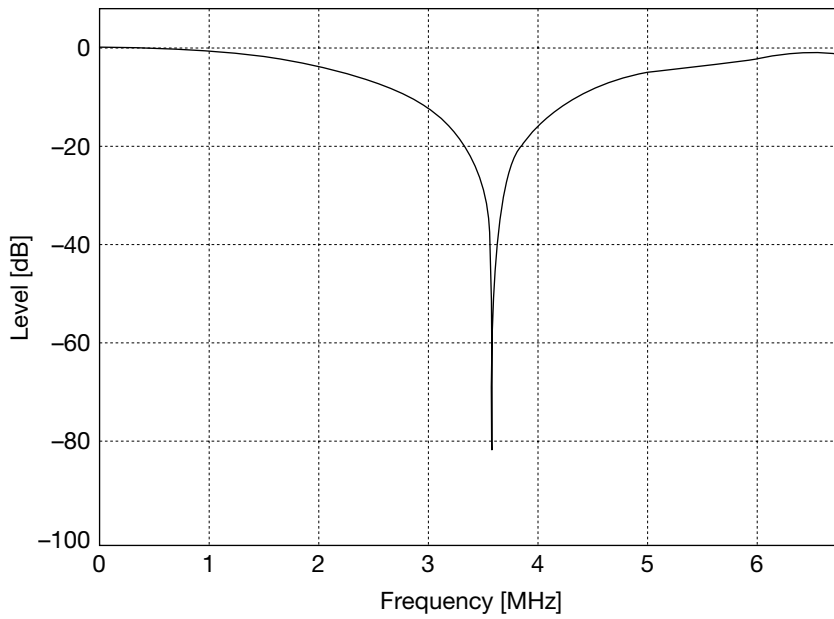

Trap Filter (PAL ITU-R601)

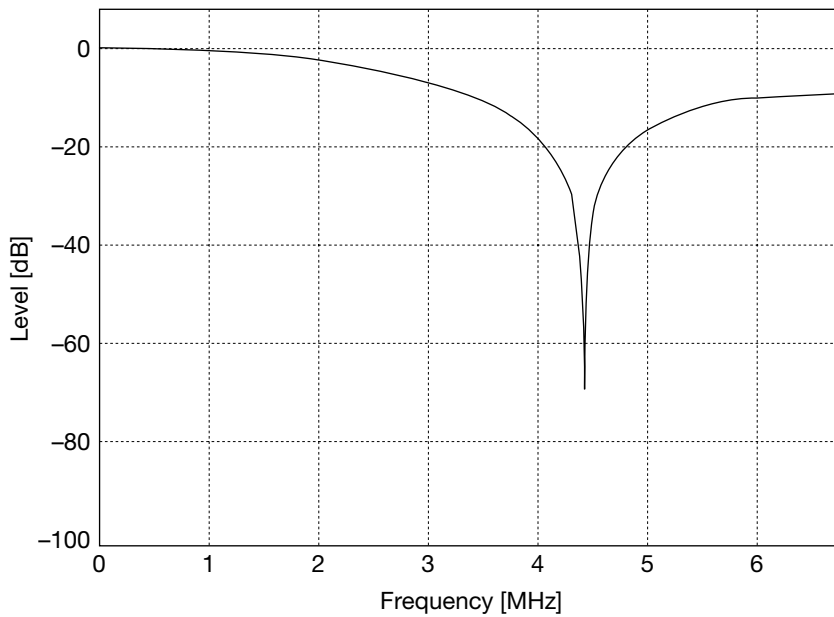

Pre Filter

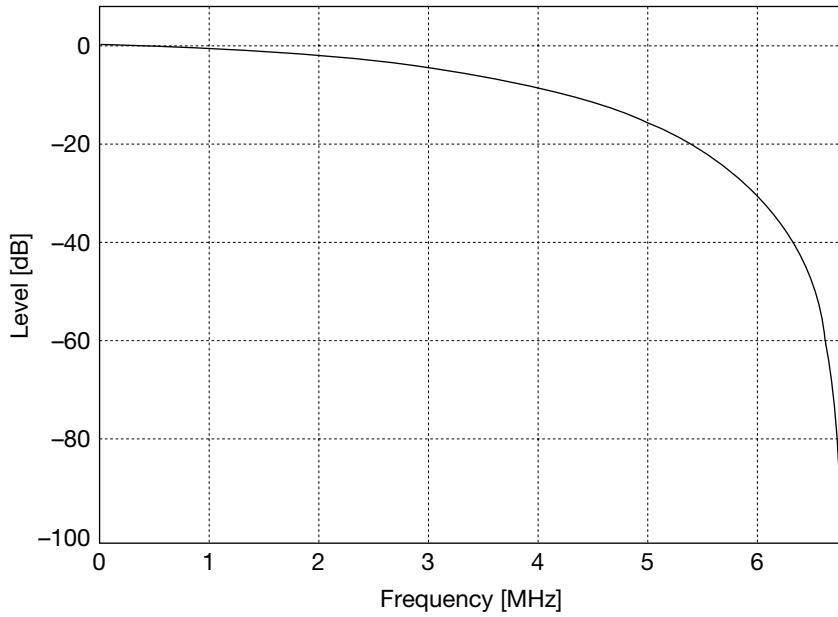

Sharp Filter

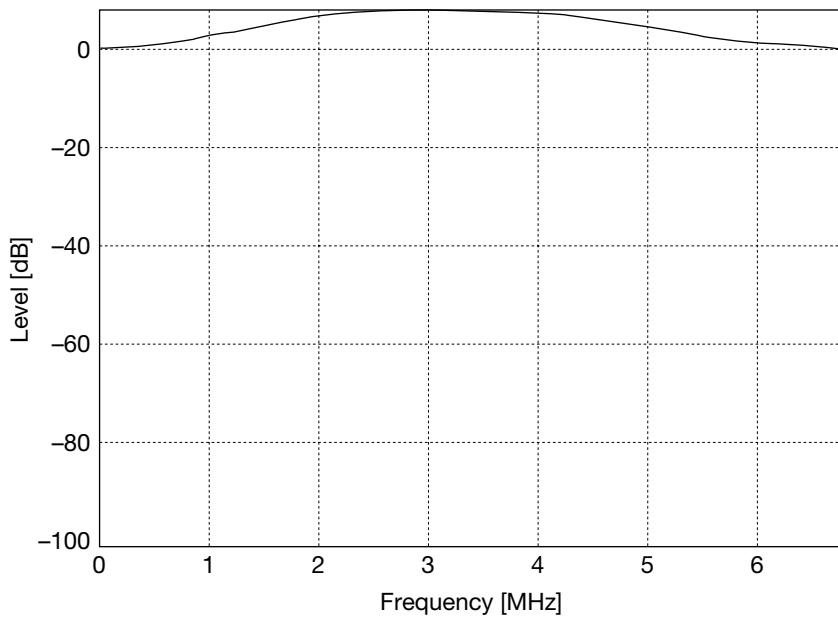

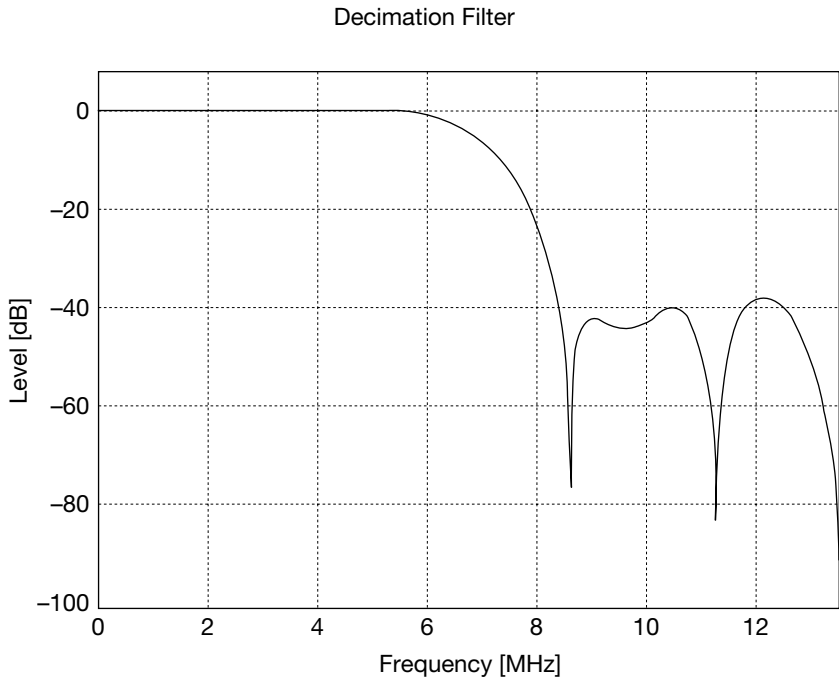

BASIC APPLICATION CIRCUIT EXAMPLES

1) Application Circuit for FIFO-1 and FIFO-2 Modes

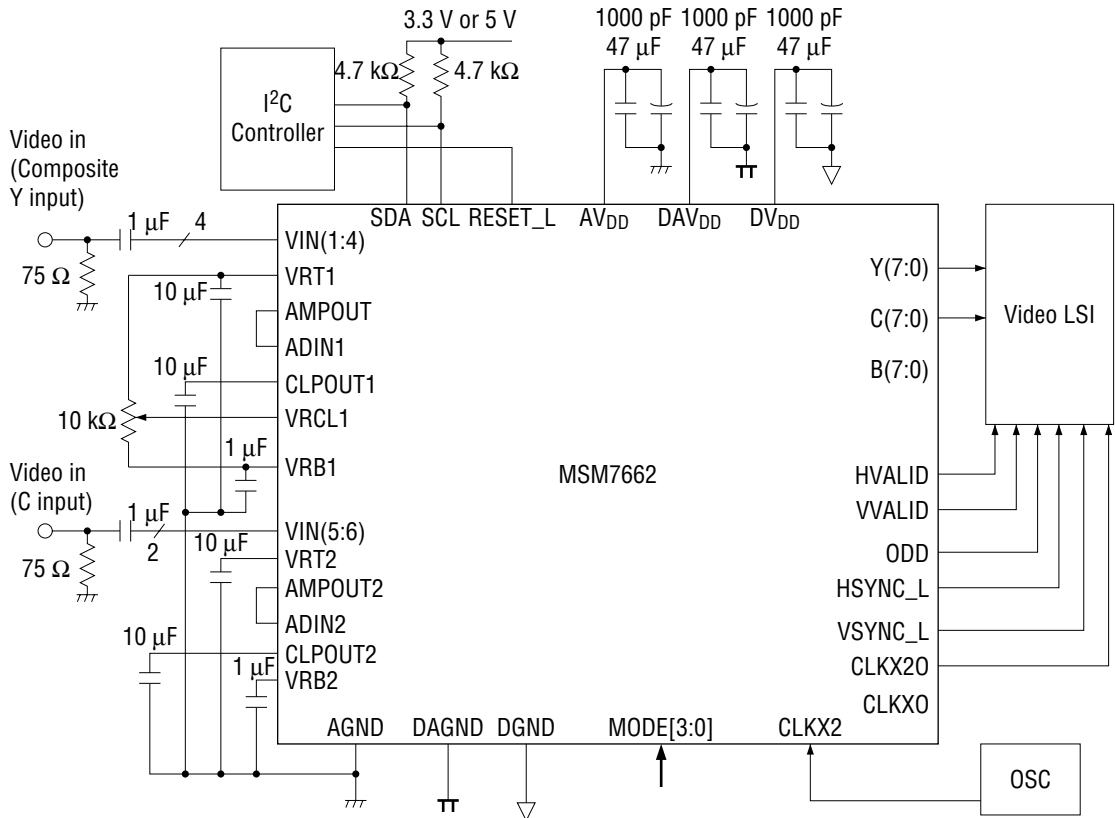

- Connect the M7662 decoder and a video LSI device according to the output interface (ITU-R656, 8-bit [YCbCr], 16-bit [YCbCr], RGB).
- Video input can be five composite inputs or two S-Video inputs.
- Connect unused video input pins to AGND. If a composite signal is input, the C input side (video amp, A/D converter, etc.) will be in the OFF operation state.
- If the input is limited by the composite signal, connect VIN (5:6), VRT2, VRB2, AMPOUT2, ADIN2, and CLPOUT2 pins to AGND. Externally attached components such as capacitors may be removed.
- Set the MODE[3:0] pins to the prescribed setting.
- Supply power and GND for analog, A/D, and digital circuits on the circuit board should be separated at the power source wherever possible. Power and GND lines for analog and A/D circuits must be wide and low impedance.

2) Application Circuit for FM-1 and FM-2 Modes

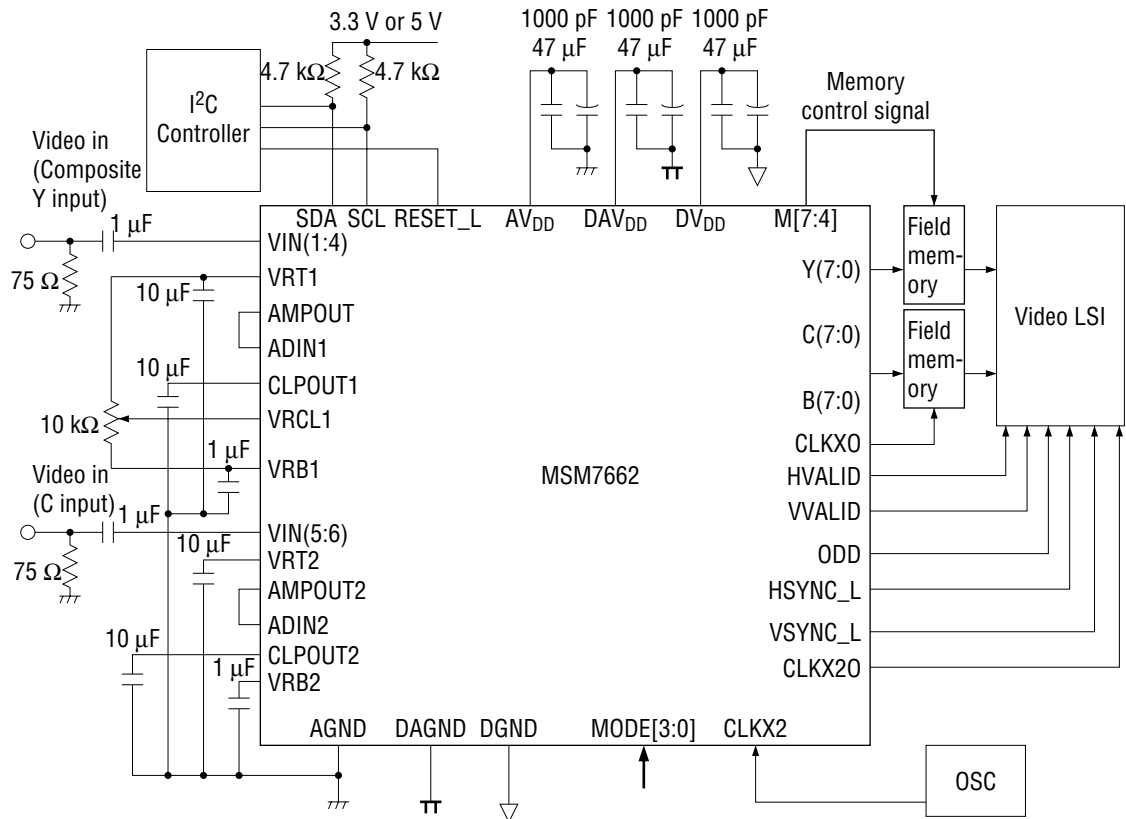

- Select either 16-bit [YCbCr] or RGB output as the output interface.
- Number of field memories utilized
 16-bit [YCbCr]: Use 2 field memories.
 RGB: Use 3 field memories.
- Video input can be five composite inputs or two S-Video inputs.
- Connect unused video input pins to AGND. If a composite signal is input, the C input side (video amp, A/D converter, etc.) will be in the OFF operation state.
- If the input is limited by the composite signal, connect VIN (5:6), VRT2, VRB2, AMPOUT2, ADIN2, and CLPOUT2 pins to AGND. Externally attached components such as capacitors may be removed.
- Set the MODE[3:0] pins to the prescribed setting.
- For the MF-1 mode setting, externally generate and supply control signals for the field memory.
- For the MF-2 mode setting, memory control signals from M[7:4] can be supplied to the field memory.
- For the MF-2 mode setting, the output timing for HSYNC_L, VSYNC_L, ODD, VVALID, and HVALID becomes the memory read timing. Data output from memory is aligned with the variout sync signal timings. (See page 24 and page 25)
- Supply power and GND for analog, A/D, and digital circuits on the circuit board should be separated at the power source wherever possible. Power and GND lines for analog and A/D circuits must be wide and low impedance.

PACKAGE DIMENSIONS

(Unit : mm)

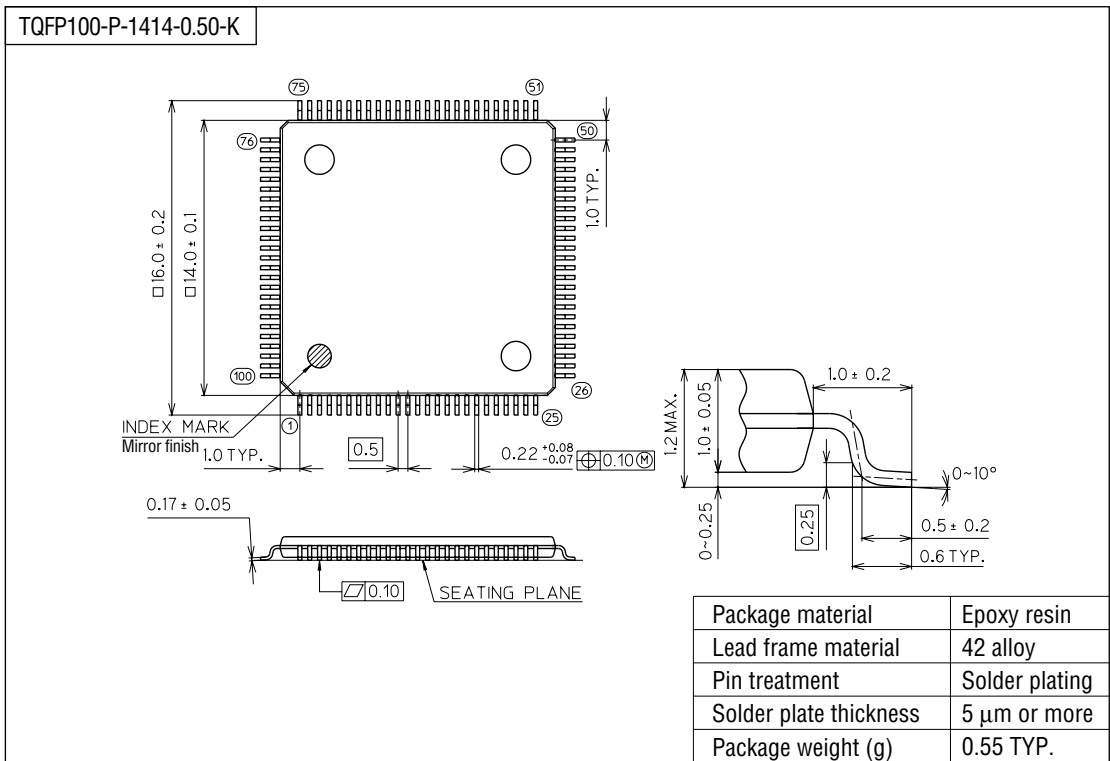

Notes for Mounting the Surface Mount Type Package

The SOP, QFP, TSOP, SOJ, QFJ (PLCC), SHP and BGA are surface mount type packages, which are very susceptible to heat in reflow mounting and humidity absorbed in storage. Therefore, before you perform reflow mounting, contact Oki's responsible sales person for the product name, package name, pin number, package code and desired mounting conditions (reflow method, temperature and times).

NOTICE

1. The information contained herein can change without notice owing to product and/or technical improvements. Before using the product, please make sure that the information being referred to is up-to-date.
2. The outline of action and examples for application circuits described herein have been chosen as an explanation for the standard action and performance of the product. When planning to use the product, please ensure that the external conditions are reflected in the actual circuit, assembly, and program designs.
3. When designing your product, please use our product below the specified maximum ratings and within the specified operating ranges including, but not limited to, operating voltage, power dissipation, and operating temperature.
4. Oki assumes no responsibility or liability whatsoever for any failure or unusual or unexpected operation resulting from misuse, neglect, improper installation, repair, alteration or accident, improper handling, or unusual physical or electrical stress including, but not limited to, exposure to parameters beyond the specified maximum ratings or operation outside the specified operating range.
5. Neither indemnity against nor license of a third party's industrial and intellectual property right, etc. is granted by us in connection with the use of the product and/or the information and drawings contained herein. No responsibility is assumed by us for any infringement of a third party's right which may result from the use thereof.
6. The products listed in this document are intended for use in general electronics equipment for commercial applications (e.g., office automation, communication equipment, measurement equipment, consumer electronics, etc.). These products are not authorized for use in any system or application that requires special or enhanced quality and reliability characteristics nor in any system or application where the failure of such system or application may result in the loss or damage of property, or death or injury to humans. Such applications include, but are not limited to, traffic and automotive equipment, safety devices, aerospace equipment, nuclear power control, medical equipment, and life-support systems.
7. Certain products in this document may need government approval before they can be exported to particular countries. The purchaser assumes the responsibility of determining the legality of export of these products and will take appropriate and necessary steps at their own expense for these.
8. No part of the contents contained herein may be reprinted or reproduced without our prior permission.
9. MS-DOS is a registered trademark of Microsoft Corporation.

Copyright 1998 Oki Electric Industry Co., Ltd.