

C to Ku BAND SUPER LOW NOISE AMPLIFIER
N-CHANNEL HJ-FET

DESCRIPTION

The NE325S01 is a Hetero Junction FET that utilizes the hetero junction to create high mobility electrons. Its excellent low noise and high associated gain make it suitable for DBS and another commercial systems.

FEATURES

- Super Low Noise Figure & High Associated Gain
NF = 0.45 dB TYP., $G_a = 12.5$ dB TYP. at $f = 12$ GHz
- Gate Length: $L_g \leq 0.20 \mu\text{m}$
- Gate Width : $W_g = 200 \mu\text{m}$

ORDERING INFORMATION

PART NUMBER	SUPPLYING FORM	MARKING
NE325S01-T1	Tape & reel 1000 pcs./reel	D
NE325S01-T1B	Tape & reel 4000 pcs./reel	

ABSOLUTE MAXIMUM RATINGS ($T_A = 25^\circ\text{C}$)

Drain to Source Voltage	V_{DS}	4.0	V
Gate to Source Voltage	V_{GS}	-3.0	V
Drain Current	I_D	I_{DSS}	mA
Gate Current	I_G	100	μA
Total Power Dissipation	P_{tot}	165	mW
Channel Temperature	T_{ch}	125	$^\circ\text{C}$
Storage Temperature	T_{stg}	-65 to +125	$^\circ\text{C}$

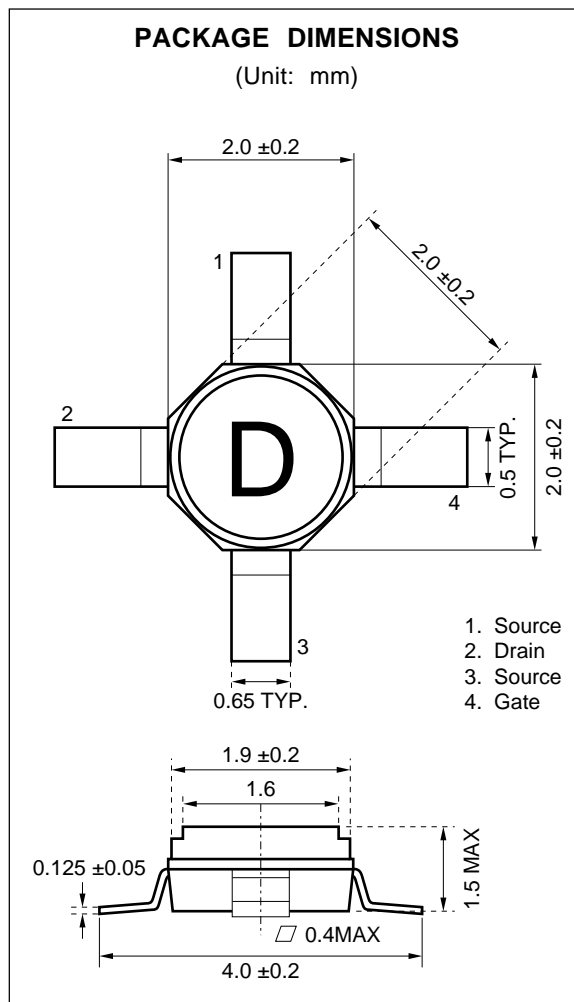

RECOMMENDED OPERATING CONDITION ($T_A = 25^\circ\text{C}$)

CHARACTERISTIC	SYMBOL	MIN.	TYP.	MAX.	Unit
Drain to Source Voltage	V_{DS}		2	3	V
Drain Current	I_D		10	20	mA
Input Power	P_{in}			0	dBm

ELECTRICAL CHARACTERISTICS (T_A = 25 °C)

CHARACTERISTIC	SYMBOL	MIN.	TYP.	MAX.	UNIT	TEST CONDITIONS
Gate to Source Leak Current	I _{GSO}		0.5	10	μA	V _{GS} = -3 V
Saturated Drain Current	I _{DSS}	20	60	90	mA	V _{DS} = 2 V, V _{GS} = 0 V
Gate to Source Cutoff Voltage	V _{GS(off)}	-0.2	-0.7	-2.0	V	V _{DS} = 2 V, I _D = 100 μA
Transconductance	g _m	45	60		mS	V _{DS} = 2V, I _D = 10 mA
Noise Figure	NF		0.45	0.55	dB	V _{DS} = 2 V, I _D = 10 mA, f = 12 GHz
Associated Gain	G _a	11.0	12.5		dB	

TYPICAL CHARACTERISTICS (T_A = 25 °C)

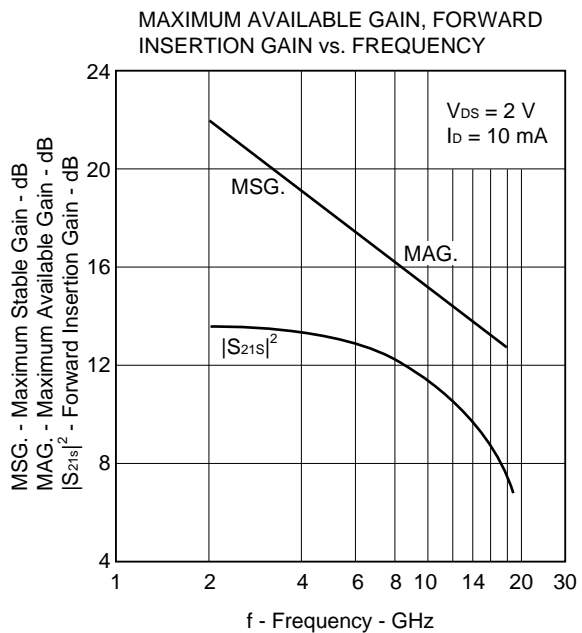
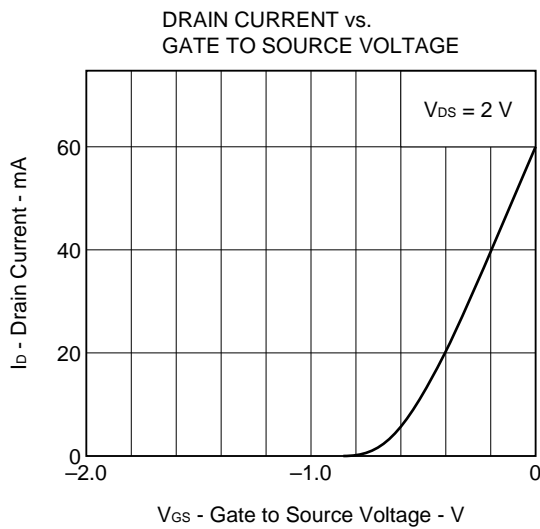
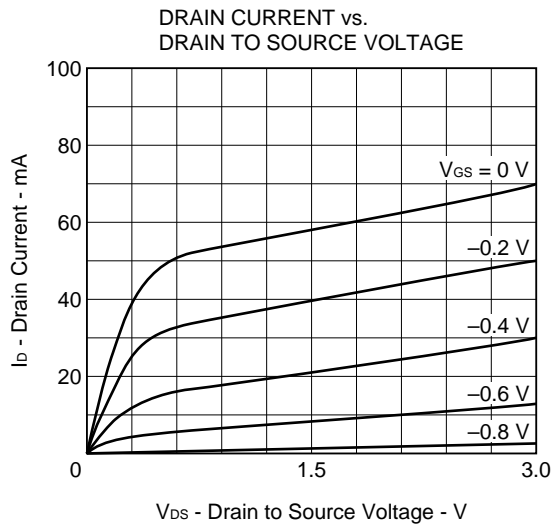
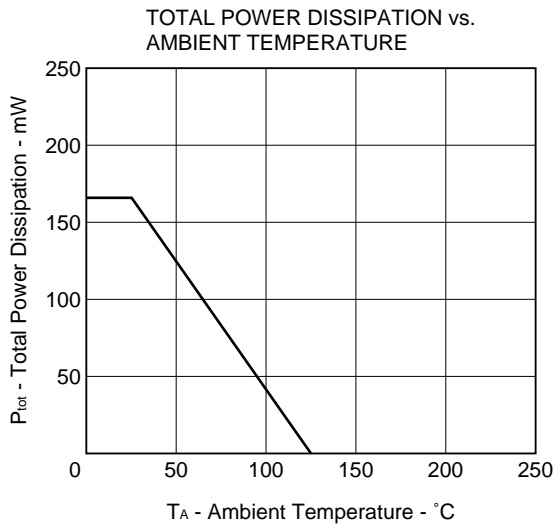

Gain Calculations

$$MSG. = \frac{|S_{21}|}{|S_{12}|}$$

$$K = \frac{1 + |\Delta|^2 - |S_{11}|^2 - |S_{22}|^2}{2 |S_{12}| |S_{21}|}$$

$$MAG. = \frac{|S_{21}|}{|S_{12}|} (K \pm \sqrt{K^2 - 1})$$

$$\Delta = S_{11} \cdot S_{22} - S_{21} \cdot S_{12}$$

NOISE FIGURE, ASSOCIATED GAIN vs. FREQUENCY

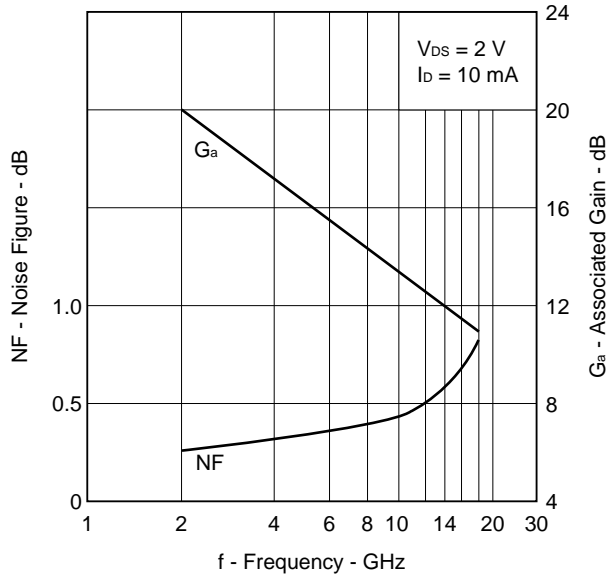

NOISE FIGURE, ASSOCIATED GAIN vs. DRAIN CURRENT

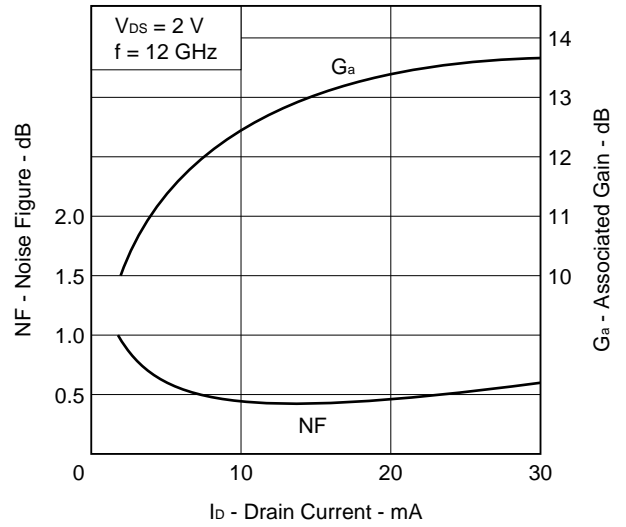

S-PARAMETERS

$V_{DS} = 2\text{ V}$, $I_D = 10\text{ mA}$

START 2 GHz, STOP 18 GHz, STEP 500 MHz

Marker
 1: 4 GHz
 2: 8 GHz
 3: 12 GHz
 4: 16 GHz
 5: 18 GHz

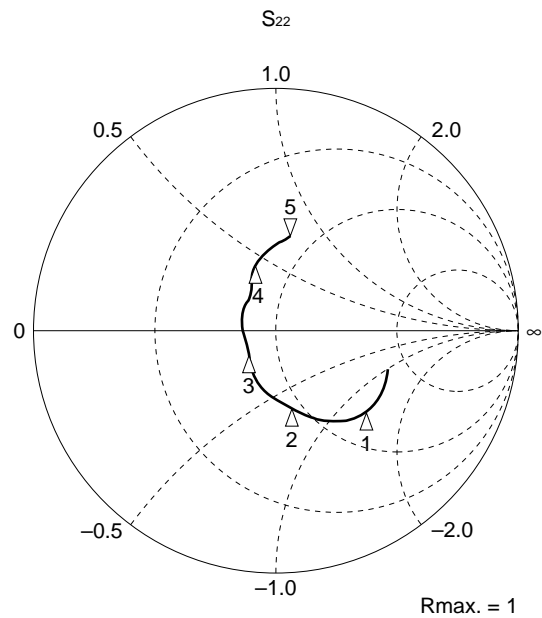
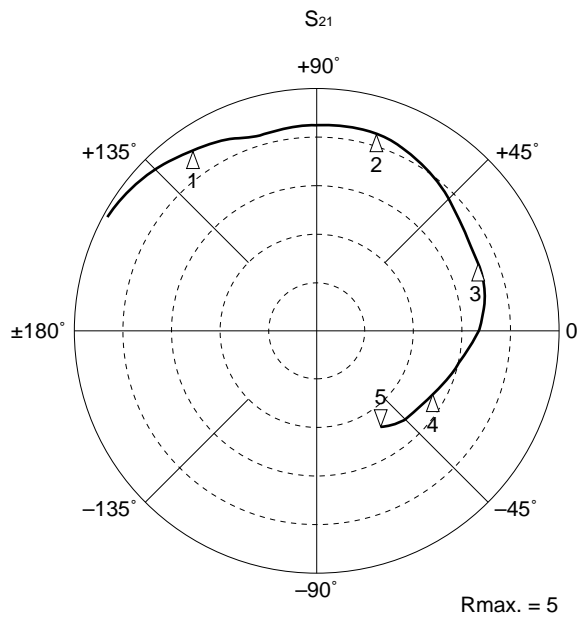
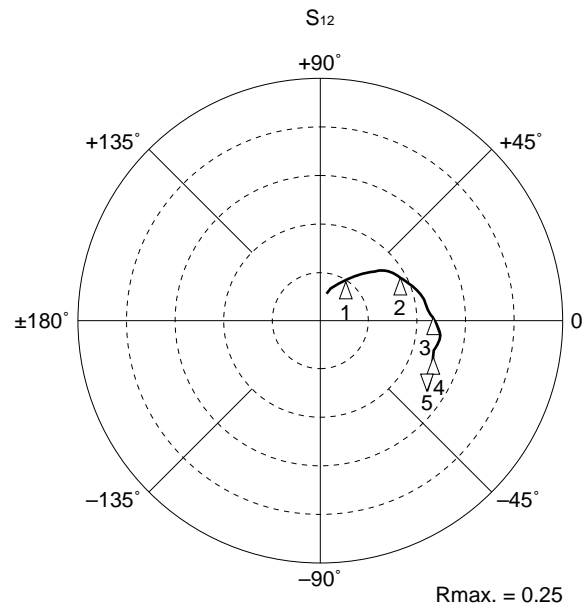
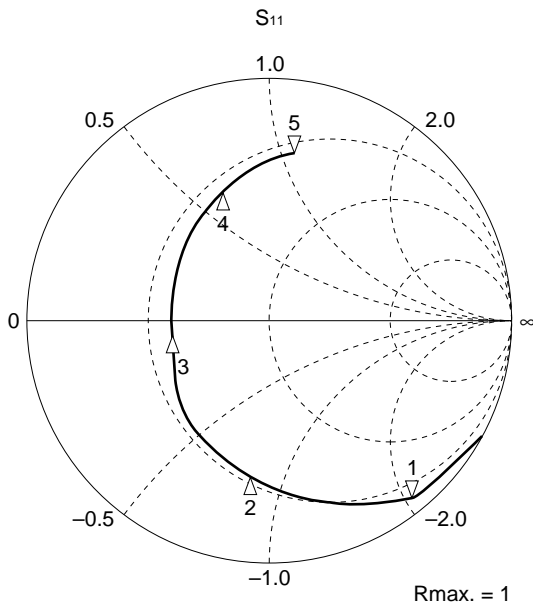

S-PARAMETERS

MAG. AND ANG.

V_{DS} = 2 V, I_D = 10 mA

FREQUENCY MHz	S ₁₁		S ₂₁		S ₁₂		S ₂₂	
	MAG.	ANG. (deg.)	MAG.	ANG. (deg.)	MAG.	ANG. (deg.)	MAG.	ANG. (deg.)
2000	.999	-26.7	4.914	151.5	.029	74.5	.444	-18.9
2500	.994	-29.0	4.748	147.2	.036	73.3	.507	-26.8
3000	.952	-38.8	4.770	137.3	.044	65.3	.472	-32.7
3500	.939	-44.6	4.654	131.3	.050	62.7	.485	-37.1
4000	.926	-51.1	4.547	125.0	.055	59.3	.490	-40.9
4500	.866	-56.7	4.413	117.6	.059	53.7	.477	-45.3
5000	.821	-60.6	4.285	111.6	.064	50.8	.474	-48.5
5500	.783	-63.7	4.192	105.7	.069	48.4	.465	-51.7
6000	.788	-70.5	4.207	99.8	.075	45.1	.439	-55.4
6500	.755	-76.1	4.219	93.7	.079	41.7	.421	-58.9
7000	.721	-82.9	4.231	87.2	.085	38.6	.401	-63.4
7500	.679	-91.9	4.234	80.0	.092	33.4	.361	-69.3
8000	.634	-101.6	4.207	72.6	.095	28.8	.322	-75.7
8500	.595	-111.7	4.136	65.3	.098	24.2	.288	-83.0
9000	.563	-122.5	4.059	58.1	.104	20.5	.256	-92.1
9500	.537	-132.5	3.958	51.1	.105	16.0	.229	-101.2
10000	.505	-142.0	3.834	44.3	.108	11.7	.208	-108.5
10500	.478	-151.0	3.735	38.3	.109	8.6	.187	-114.8
11000	.451	-159.2	3.647	32.5	.110	5.3	.164	-120.0
11500	.421	-168.7	3.609	26.6	.112	1.9	.147	-124.7
12000	.415	179.9	3.589	20.6	.115	.3	.124	-133.2
12500	.424	167.1	3.556	13.4	.116	-3.3	.108	-151.1
13000	.448	152.5	3.473	5.5	.122	-7.9	.103	175.2
13500	.477	138.9	3.331	-1.8	.121	-13.1	.126	143.2
14000	.508	128.1	3.161	-8.5	.118	-15.9	.157	120.6
14500	.530	120.0	3.006	-14.2	.115	-18.0	.184	110.2
15000	.554	113.2	2.913	-19.4	.118	-18.9	.214	106.0
15500	.579	109.4	2.822	-24.6	.118	-19.9	.235	102.0
16000	.595	104.0	2.753	-30.6	.120	-22.0	.264	100.0
16500	.625	97.3	2.685	-37.0	.121	-25.5	.297	94.1
17000	.652	89.6	2.601	-43.8	.123	-30.4	.317	88.4
17500	.688	82.2	2.505	-50.8	.124	-34.2	.345	82.5
18000	.709	75.3	2.372	-57.2	.122	-37.3	.383	76.2

AMP. PARAMETERS

V_{DS} = 2 V, I_D = 10 mA

FREQUENCY MHz	GU _{max} dB	GA _{max} dB	S ₂₁ ² dB	S ₁₂ ² dB	K	Delay ns	Mason's U dB	G1 dB	G2 dB
2000			13.83	-30.68	.02	.024			.95
2500	34.12		13.53	-28.81	.05	.024		19.30	1.29
3000	24.91		13.57	-27.20	.25	.055		10.25	1.09
3500	23.80		13.36	-26.07	.27	.033		9.28	1.16
4000	22.80		13.15	-25.22	.29	.035		8.45	1.19
4500	20.04		12.89	-24.56	.48	.041	30.046	6.02	1.12
5000	18.61		12.64	-23.90	.59	.033	25.177	4.86	1.11
5500	17.63		12.45	-23.24	.67	.032	23.488	4.12	1.06
6000	17.62		12.48	-22.45	.64	.033	26.711	4.21	.93
6500	17.02		12.50	-22.08	.70	.034	25.122	3.67	.85
7000	16.47		12.53	-21.45	.73	.036	25.323	3.18	.76
7500	15.82		12.53	-20.71	.78	.040	23.957	2.68	.61
8000	15.19		12.48	-20.45	.84	.041	22.607	2.23	.48
8500	14.60		12.33	-20.15	.89	.040	21.735	1.90	.38
9000	14.12		12.17	-19.69	.91	.040	21.968	1.66	.29
9500	13.66		11.95	-19.57	.96	.039	21.196	1.48	.23
10000	13.15	15.21	11.67	-19.29	1.00	.038	20.248	1.28	.19
10500	12.73	13.86	11.45	-19.29	1.06	.033	19.297	1.13	.15
11000	12.34	13.15	11.24	-19.19	1.11	.032	18.449	.99	.12
11500	12.09	12.73	11.15	-19.05	1.15	.033	17.976	.85	.09
12000	11.99	12.61	11.10	-18.81	1.15	.033	18.424	.82	.07
12500	11.93	12.56	11.02	-18.74	1.15	.040	18.844	.86	.05
13000	11.83	12.56	10.81	-18.31	1.11	.044	19.943	.97	.05
13500	11.64	12.31	10.45	-18.38	1.12	.040	19.641	1.12	.07
14000	11.40	11.91	10.00	-18.54	1.15	.037	18.906	1.30	.11
14500	11.14	11.54	9.56	-18.76	1.19	.031	18.016	1.43	.15
15000	11.08	11.50	9.29	-18.59	1.16	.029	18.476	1.59	.20
15500	11.03	11.49	9.01	-18.57	1.14	.029	18.729	1.77	.25
16000	11.00	11.57	8.79	-18.42	1.11	.033	19.308	1.90	.31
16500	11.13	11.87	8.58	-18.33	1.07	.036	20.642	2.15	.40
17000	11.16	12.17	8.30	-18.19	1.03	.037	22.203	2.40	.46
17500	11.31		7.97	-18.10	.98	.039	25.645	2.78	.55
18000	11.22		7.50	-18.28	.99	.035	22.558	3.03	.69

NOISE PARAMETER
<TYPICAL CONSTANT NOISE FIGURE CIRCLE>

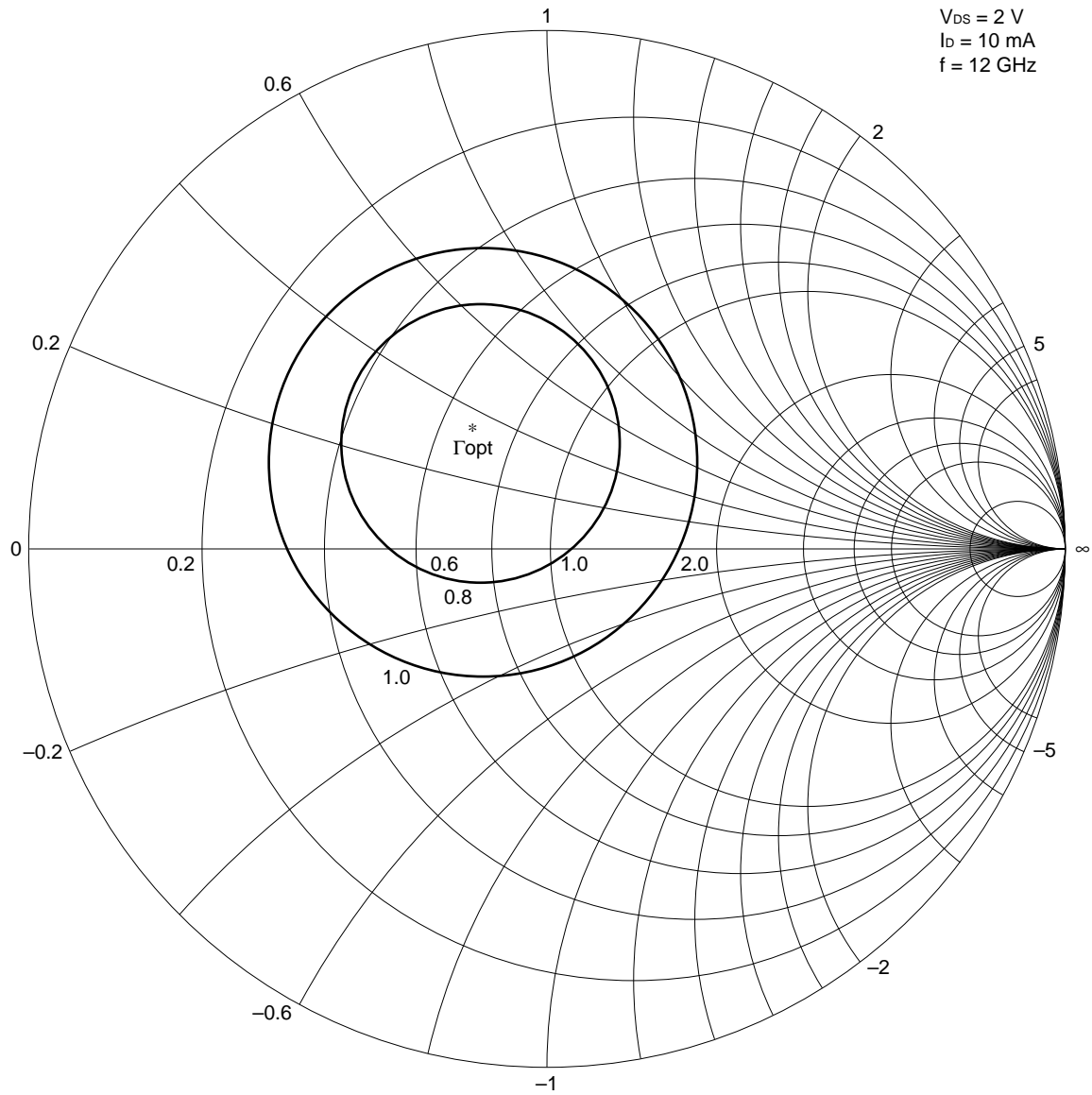

<NOISE PARAMETER>

V_{DS} = 2 V, I_D = 10 mA

Freq. (GHz)	NF _{min.} (dB)	G _a (dB)	Γ _{opt.}		R _n /50
			MAG.	ANG. (deg.)	
2.0	0.29	20.0	0.93	14	0.38
4.0	0.30	18.3	0.80	29	0.33
6.0	0.32	16.5	0.65	48	0.25
8.0	0.35	15.0	0.49	72	0.18
10.0	0.40	13.6	0.36	102	0.11
12.0	0.45	12.5	0.27	139	0.08
14.0	0.53	12.0	0.24	-176	0.07
16.0	0.67	11.8	0.30	-122	0.10
18.0	0.83	11.5	0.47	-58	0.22

TYPICAL MOUNT PAD LAYOUT

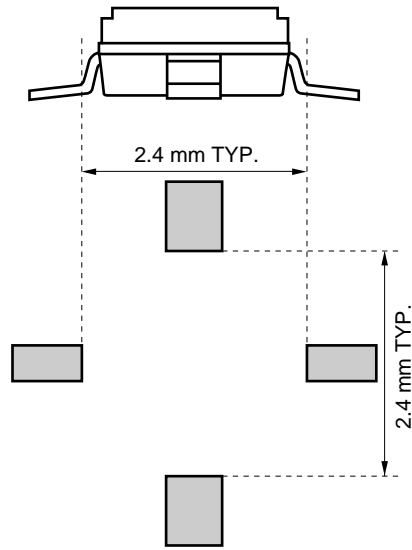

RECOMMENDED SOLDERING CONDITIONS

The following conditions (see table below) must be met when soldering this product.

Please consult with our sales offices in case other soldering process is used, or in case soldering is done under different conditions.

<TYPES OF SURFACE MOUNT DEVICE>

For more details, refer to our document “SEMICONDUCTOR DEVICE MOUNTING TECHNOLOGY MANUAL” (C10535E).

Soldering process	Soldering conditions	Symbol
Infrared ray reflow	Peak package’s surface temperature: 230 °C or below, Reflow time: 30 seconds or below (210 °C or higher), Number of reflow process: 1, Exposure limit ^{Note} : None	IR30-00
Partial heating method	Terminal temperature: 230 °C or below, Flow time: 10 seconds or below, Exposure limit ^{Note} : None	

Note Exposure limit before soldering after dry-pack package is opened.

Storage conditions: 25 °C and relative humidity at 65 % or less.

Caution Do not apply more than a single process at once, except for “Partial heating method”.

PRECAUTION Avoid high static voltage and electric fields, because this device is Hetero Junction field effect transistor with shottky barrier gate.

[MEMO]

[MEMO]

Caution

The Grate Care must be taken in dealing with the devices in this guide.

The reason is that the material of the devices is GaAs (Gallium Arsenide), which is designated as harmful substance according to the law concerned.

Keep the law concerned and so on, especially in case of removal.

No part of this document may be copied or reproduced in any form or by any means without the prior written consent of NEC Corporation. NEC Corporation assumes no responsibility for any errors which may appear in this document.

NEC Corporation does not assume any liability for infringement of patents, copyrights or other intellectual property rights of third parties by or arising from use of a device described herein or any other liability arising from use of such device. No license, either express, implied or otherwise, is granted under any patents, copyrights or other intellectual property rights of NEC Corporation or others.

While NEC Corporation has been making continuous effort to enhance the reliability of its semiconductor devices, the possibility of defects cannot be eliminated entirely. To minimize risks of damage or injury to persons or property arising from a defect in an NEC semiconductor device, customers must incorporate sufficient safety measures in its design, such as redundancy, fire-containment, and anti-failure features.

NEC devices are classified into the following three quality grades:

"Standard", "Special", and "Specific". The Specific quality grade applies only to devices developed based on a customer designated "quality assurance program" for a specific application. The recommended applications of a device depend on its quality grade, as indicated below. Customers must check the quality grade of each device before using it in a particular application.

Standard: Computers, office equipment, communications equipment, test and measurement equipment, audio and visual equipment, home electronic appliances, machine tools, personal electronic equipment and industrial robots

Special: Transportation equipment (automobiles, trains, ships, etc.), traffic control systems, anti-disaster systems, anti-crime systems, safety equipment and medical equipment (not specifically designed for life support)

Specific: Aircrafts, aerospace equipment, submersible repeaters, nuclear reactor control systems, life support systems or medical equipment for life support, etc.

The quality grade of NEC devices is "Standard" unless otherwise specified in NEC's Data Sheets or Data Books. If customers intend to use NEC devices for applications other than those specified for Standard quality grade, they should contact an NEC sales representative in advance.

Anti-radioactive design is not implemented in this product.