

10/100BASE-TX

Magnetics Modules

Electrical Specifications @25

HIPOT: 1500Vrms (Input to Output)
 Turns Ratio (1-3-2):(16-14-15) = 1CT:1CT ±3%
 Turns Ratio (7-6-8):(10-11-9) = 1CT:1CT ±3%
 OCL: 350uH Minimum @100KHz 100mV 8mADC
 DCR: PIN1-2,PIN9-10 0.9 ohms Maximum
 PIN7-8,PIN16-15 0.4 ohms Maximum
 Insertion Loss: -1.0dB Maximum @1MHz~100MHz
 Return Loss: -18dB Minimum @30MHz
 -12dB Minimum @60MHz
 -11dB Minimum @80MHz
 Differential to Common Mode Rejection: -30dB Min @30MHz~100MHz
 -20dB Min @150MHz
 Crosstalk: -40dB Min @30MHz / -40dB Min @62MHz / -35dB Min @100MHz

Mechanicals:

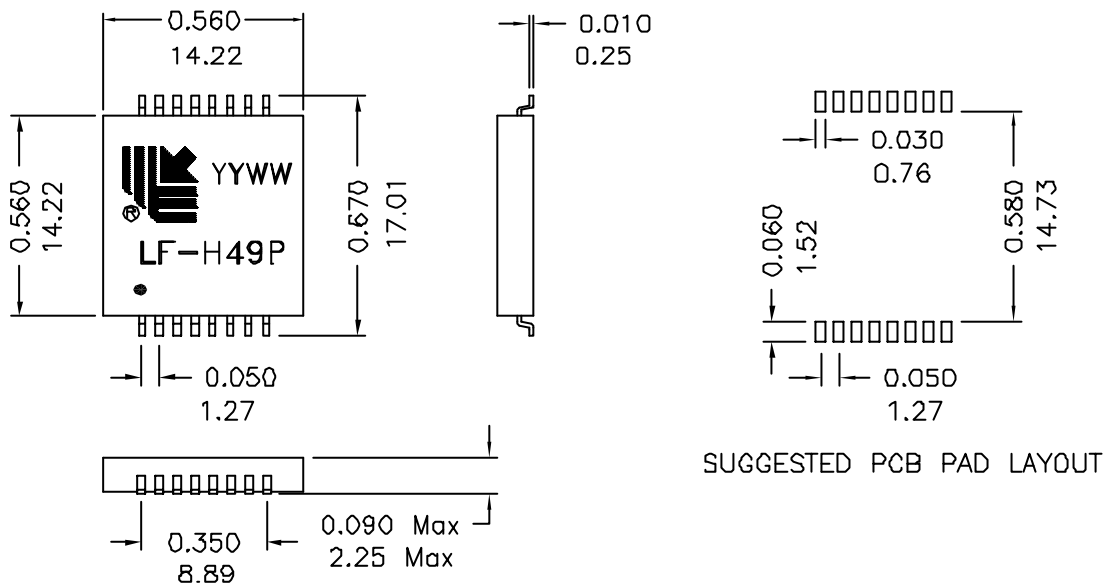

Schematics:

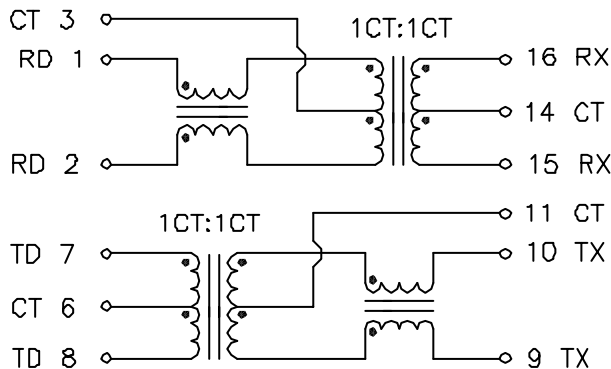

*Specification Subject to Shange Without Notice.

P/N: LF-H49P	DIMENSIONS IN	Unless otherwise specified Dim. Tolerances are: .xxx ±0.010 inch	REV: A1	DRWN:	DATE: 03-09-22
	SCALE: NONE		PAGE: 1/1	APPD:	DATE: