

## Charge Pump LED Driver For Camera Flash

### FEATURES

- High Output Current Charge Pump: 700mA
- Adjustable FLASH mode
- x1 and x2 Automatic Modes for High Efficiency
- Minimum External Components: No Inductors
- High Frequency Operation: 2.4 MHz
- Low 50mV reference for low loss sensing
- 1  $\mu$ A shutdown current
- PWM Dimming Control
- Over voltage protection on output
- Over current protection
- Over temperature protection
- Space Saving 10-pin 3mm x 3mm DFN Package

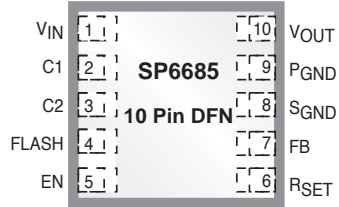

*Now Available in Lead Free Packaging*

### APPLICATIONS

- LED Torch/Flash for Cell Phones, DSCs, and Camcorders
- Generic Lighting/Flash/Strobe Applications

### DESCRIPTION

The SP6685 is a current regulated charge pump ideal for powering high brightness LEDs for camera flash applications. The charge pump can be set to regulate two current levels for FLASH and TORCH modes. The SP6685 automatically switches modes between step-up and step-down ensuring that LED current does not depend on the forward voltage. A low current sense reference voltage (50mV) allows the use of small 0603 current sensing resistors. The SP6685 is offered in 10-pin DFN package.

### TYPICAL APPLICATION CIRCUIT

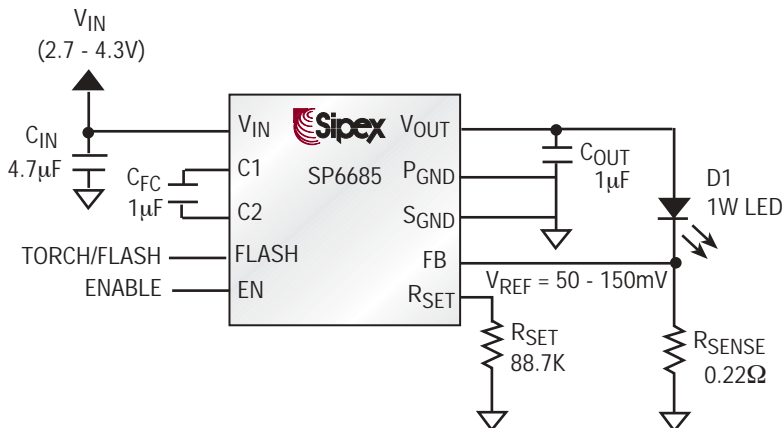

## ABSOLUTE MAXIMUM RATINGS

$V_{IN} - V_{OUT}$ .....	-0.3V to 6V
Output Current Pulse (Flash) .....	1A
Output Current Continuous (Torch) .....	0.4A
Storage Temperature .....	-65°C to +150°C
Operating Temperature .....	-40°C to +85°C
EN .....	0V to 7V
ESD .....	2kV HBM

These are stress ratings only and functional operation of the device at these ratings or any other above those indicated in the operation sections of the specifications below is not implied. Exposure to absolute maximum rating conditions for extended periods of time may affect reliability.

## ELECTRICAL CHARACTERISTICS

$T_A = -40^\circ\text{C}$  to  $+85^\circ\text{C}$ ,  $V_{IN} = 3.6$ ,  $C_{IN} = 4.7\mu\text{F}$ ,  $C_{FC} = C_{OUT} = 1.0\mu\text{F}$ .  $V_{SHDN} = V_{IN}$ , typical values at  $25^\circ\text{C}$ . The  $\blacklozenge$  denotes the specifications which apply over the full operating range unless otherwise noted.

PARAMETER	MIN.	TYP.	MAX.	UNITS		CONDITIONS
Operating Input Voltage	2.7		4.3	V	$\blacklozenge$	
Quiescent Current		0.5	2	mA	$\blacklozenge$	$V_{IN} = 2.7 - 4.3\text{V}$ FLASH = 0V, $I_{load} = 100\mu\text{A}$
		2				FLASH = $V_{IN}$ , 2x mode
Shutdown Current			1	$\mu\text{A}$	$\blacklozenge$	$V_{IN} = 4.3\text{V}$ , $V_{EN} = 0\text{V}$
Oscillator Frequency		2.4		MHz	$\blacklozenge$	
Charge Pump Equivalent Resistance (x2 mode)		5		$\Omega$		$V_{FB} = 0\text{V}$ , $V_{IN} = 3.6\text{V}$
Charge Pump Equivalent Resistance (x1 mode)		0.6	0.8	$\Omega$		$V_{IN} = 3.6\text{V}$
FB Reference Voltage	142	150	158	mV	$\blacklozenge$	FLASH = $V_{IN}$ , $R_{SET} = 100\text{K}$
FB Reference Voltage	45	50	55	mV	$\blacklozenge$	FLASH = GND
FB Pin Current			0.5	$\mu\text{A}$	$\blacklozenge$	$V_{FB} = 1\text{V}$
EN, FLASH Logic Low			0.4	V	$\blacklozenge$	
EN, FLASH Logic High	1.3			V	$\blacklozenge$	
EN, FLASH Pin Current			0.5	$\mu\text{A}$	$\blacklozenge$	
$V_{OUT}$ Turn-on Time		250	500	$\mu\text{s}$	$\blacklozenge$	$V_{IN} = 3.6\text{V}$ , FB within 90% of regulation
Thermal Shutdown Temperature		145		$^\circ\text{C}$		
Thermal Hysteresis		10		$^\circ\text{C}$		

PIN NUMBER	PIN NAME	DESCRIPTION
1	V <sub>IN</sub>	Input Voltage for the charge pump. Decouple with 1μF ceramic capacitor close to the pins of the IC.
2	C1	Positive input for the external fly capacitor. Connect a ceramic 1μF capacitor close to the pins of the IC.
3	C2	Negative input for the external fly capacitor. Connect a ceramic 1μF capacitor close to the pins of the IC.
4	FLASH	Logic input to toggle operation between FLASH and TORCH mode. In TORCH mode FB is regulated to the internal 50mV reference. In FLASH mode FB reference voltage can be adjusted by changing the resistor from R <sub>SET</sub> pin to ground. Choose the external current sense resistor (R <sub>SENSE</sub> ) based on desired current in TORCH mode. The FLASH mode should be limited to 200ms to avoid overheating the charge pump.
5	EN	Shutdown control input. Connect to V <sub>IN</sub> for normal operation, connect to ground for shutdown.
6	R <sub>SET</sub>	Connect a resistor from this pin to ground. When in FLASH mode (FLASH = High) this resistor sets the current regulation point according to the following: $V_{FB} = (1.26V / R_{SET}) * 11.2K\Omega$ .
7	FB	Feedback input for the current control loop. Connect directly to the current sense resistor.
8	S <sub>GND</sub>	Internal ground pin. Control circuitry returns current to this pin.
9	P <sub>GND</sub>	Power ground pin. Fly capacitor current returns through this pin.
10	V <sub>OUT</sub>	Charge Pump Output Voltage. Decouple with an external capacitor. At least 1uF is recommended. Higher capacitor values reduce output ripple.

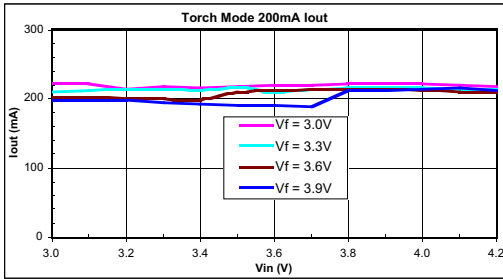

Figure 1. Torch Mode Output Current

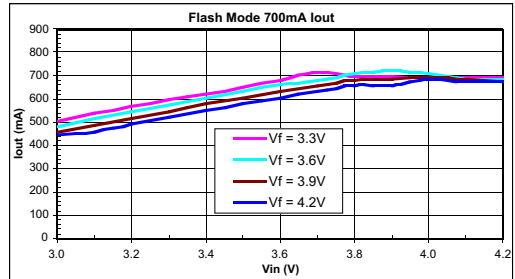

Figure 2. Flash Mode Output Current

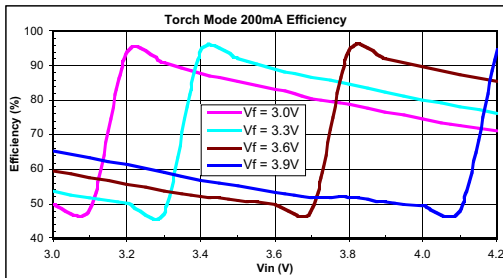

Figure 3. Torch Mode Efficiency

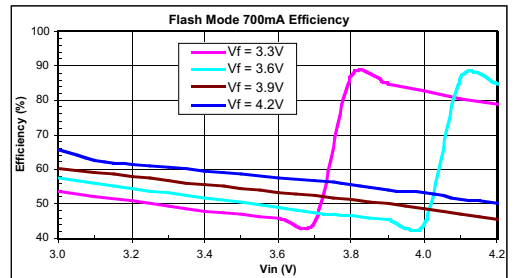

Figure 4. Flash Mode Efficiency

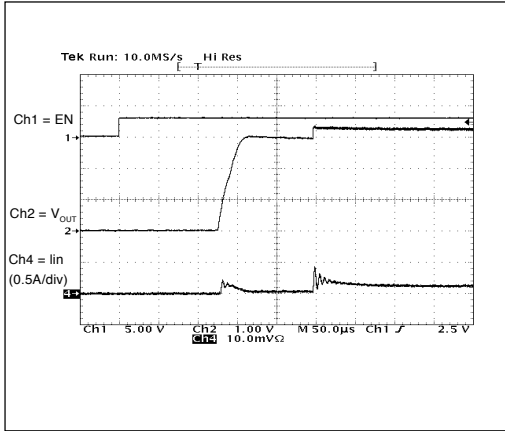

Figure 5. Startup 200mA Torch,  $V_{IN} = 3.6V$ ,  $V_{OUT} = 3.2V$

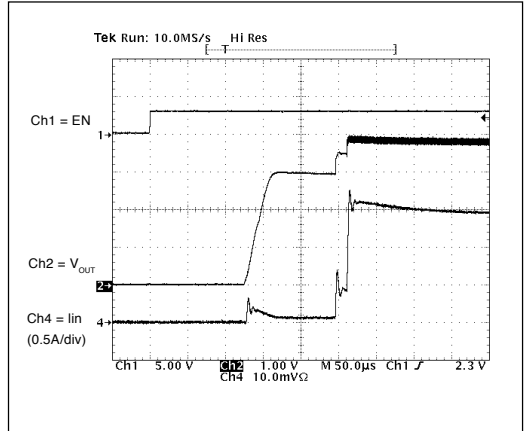

Figure 6. Startup 700mA Flash,  $V_{IN} = 3.6V$ ,  $V_{OUT} = 3.6V$

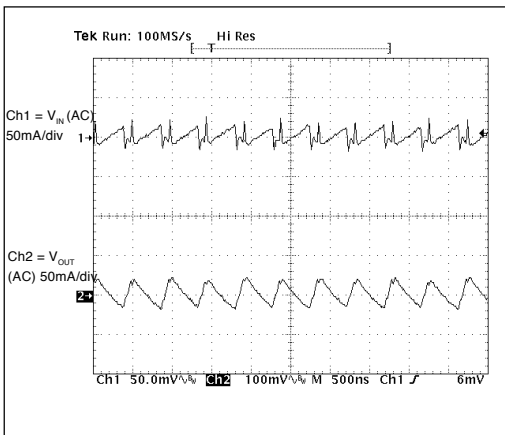

Figure 7. Ripple 200mA Torch,  $V_{IN} = 3.6V$ ,  $V_{OUT} = 3.2V$ .

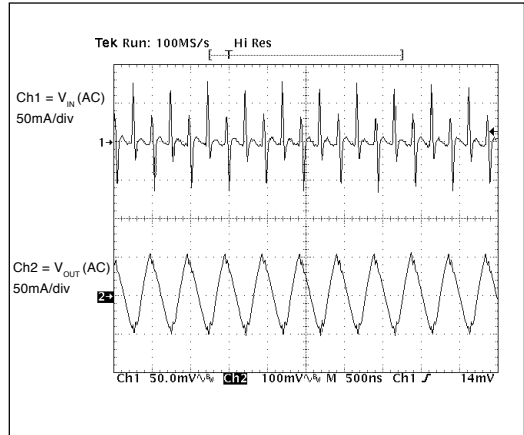

Figure 8. Ripple 700mA Flash,  $V_{IN} = 3.6V$ ,  $V_{OUT} = 3.6V$ .



---

## THEORY OF OPERATION

regulation point for more than 32 cycles of the internal clock, the SP6685 automatically switches to the 2X mode. The SP6685 remains in the 2X mode until one of four things happens: the enable pin EN has been toggled, the Flash pin has changed from high to low,  $V_{IN}$  is cycled or a thermal fault occurs. The 2X mode is the charge pump mode where the output can be pumped as high as two times the input voltage, provided the output does not exceed the maximum voltage for the SP6685, which is internally limited to about 4.3V. In the 2X mode, as in the 1X mode, the output current is regulated by the voltage at the FB pin.

In the Torch mode, (Flash = GND) the Flash pin is set to logic low and the SP6685 FB pin regulates to 50mV output:

$$V_{FB} = 50\text{mV (Torch Mode)}$$

When in Flash mode, (Flash =  $V_{IN}$ ), the FB regulation voltage is set by the resistor  $R_{SET}$  connected between the  $R_{SET}$  pin and  $S_{GND}$  and the equation:

$$V_{FB} = (1.26\text{V} / R_{SET}) * 11.2\text{K}\Omega \text{ (Flash Mode)}$$

Where 1.26V is the internal bandgap reference voltage and 11.2K $\Omega$  is an internal resistance used to scale the  $R_{SET}$  current. Typical values of  $R_{SET}$  are 100K to 500K for a range of  $V_{FB} = 150\text{mV}$  to 30mV in Flash mode.

The output current is then set in either Flash or Torch mode by the equation:

$$I_{OUT} = V_{FB} / R_{SENSE}$$

---

## OVERTEMPERATURE PROTECTION

When the temperature of the SP6685 rises above 145 degrees Celsius, the over temperature protection circuitry turns off the output switches to prevent damage to the device. If the temperature drops back down below 135 degrees Celsius, the part automatically recovers and executes a soft start cycle.

---

## OVERVOLTAGE PROTECTION

The SP6685 has over voltage protection. If the output voltage rises above the 4.3V threshold, the over voltage protection shuts off all of the output switches to prevent the output voltage from rising further. When the output decreases below 4.3V, the device resumes normal operation

---

## OVERCURRENT PROTECTION

The over current protection circuitry monitors the average current out of the  $V_{OUT} = 50\text{mV}$  (Torch Mode) pin. If the average output current exceeds approximately 1Amp, then the over current protection circuitry shuts off the output switches to protect the chip.

The SP6685 charge pump circuit requires 3 capacitors: input, output and fly capacitor, and a 1  $\mu$ F value is typically recommended. For the input capacitor, a larger value of 2.2 $\mu$ F or 4.7 $\mu$ F will help reduce input voltage ripple for applications sensitive to ripple on the battery voltage. All the capacitors should be ceramic to obtain low ESR, which improves bypassing on the input and output and improves output voltage drive by reducing output resistance. X5R or X7R Ceramic capacitors are recommended for most applications. A selection of recommended capacitors is included in Table 1. The input and output capacitors should be located as close to the  $V_{IN}$  and  $V_{OUT}$  pins as possible to obtain best bypassing, and the returns should be connected directly to the  $P_{GND}$  pin or to the thermal pad ground located under the SP6685. The fly capacitor should be located as close as possible to the C1 and C2 pins as possible.

The sense resistor  $R_{sense}$  is determined by the value needed in the Torch mode for the desired output current by the equation:

$$R_{SENSE} = V_{FB} / I_{OUT} \text{ where } V_{FB} = 50\text{mV (Torch Mode)}$$

Once the  $R_{SENSE}$  resistor has been selected for Torch mode, the  $V_{FB}$  voltage can be selected for Flash mode using the following equation:

$$V_{FB} = I_{OUT} * R_{SENSE} \text{ (Flash Mode) where } I_{OUT} \text{ is for Flash Mode}$$

Next, the  $R_{SET}$  resistor can be selected for Flash mode using the following equation:

$$R_{SET} = (1.26\text{V} / V_{FB}) * 11.2\text{K}\Omega \text{ (Flash Mode)}$$

For an example of 200mA Torch mode and 600mA Flash mode, the values  $R_{SENSE} = 0.25\Omega$ ,  $V_{FBREF} = 150\text{mV}$  (Flash Mode), and  $R_{SET} = 88.7\text{K}$  are calculated. The power obtained in the Flash mode would be:

$$P_{FLASH} = V_{FB} * I_{OUT} = 150\text{mV} * 600\text{mA} = 90\text{mW}.$$

The typical 0603 surface mount resistor is rated 1/10 watt continuous power and 1/5 watt pulsed power, more than enough for this application. For other applications, the  $P_{FLASH}$  can be calculated from the resistor size selected. The  $R_{SENSE}$  resistor is recommended to be size 0603 for most applications.

Part Reference	Part Number	Value	Size	Manufacturers/ Website
U1	SP6685ER		3x3mm DFN - 10 pin	Sipex/www.sipex.cpm
CIN	GRM188R0J475KE19	4.7 $\mu$ F/6.3V	0603/X5R/0.9mm ht	Murata/www.murata.com
COUT, CF	GRM155R60J105KE19B	1 $\mu$ F/6.3V	0402/X5R/0.5mm ht	Murata/www.murata.com
RSET	-	88.7K	0402	any
RSENSE	-	0.22ohms	0603	any



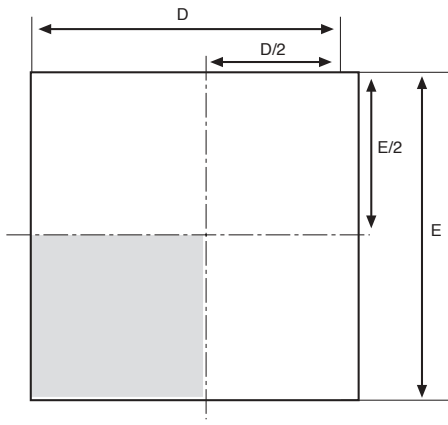

Top View

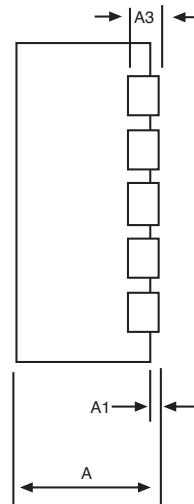

Side View

3x3 10 Pin DFN JEDEC MO-229 (VEED-5) VARIATION			
SYMBOL	MIN	NOM	MAX
A	0.8	0.9	1
A1	0	0.02	0.05
A2	0.55	0.65	0.8
A3	0.20 REF		
b	0.18	0.25	0.3
D	2.00 BSC		
D2	2.2		2.7
e	0.5 PITCH		
E	3.00 BSC		
E2	1.4	-	1.75
K	0.2	-	-
L	0.3	0.4	0.5

Note: Dimensions in (mm)

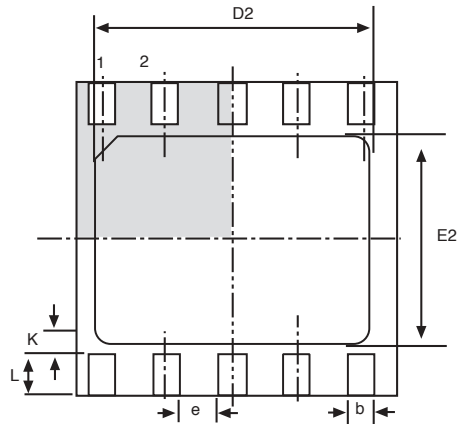

Bottom View

---

**ORDERING INFORMATION**

<b>Part Number</b>	<b>Operating Temperature Range</b>	<b>Package Type</b>
SP6685ER .....	-40°C to +85°C .....	10 Pin DFN
SP6685ER/TR .....	-40°C to +85°C .....	10 Pin DFN

Available in lead free packaging. To order add “-L” suffix to part number.

Example: SP6685ER/TR = standard; SP6685ER-L/TR = lead free

/TR = Tape and Reel

Pack quantity is 3,000 for DFN.

---

 [CLICK HERE TO ORDER SAMPLES](#) 



**ANALOG EXCELLENCE**

**Sipex Corporation**

**Headquarters and  
Sales Office**

233 South Hillview Drive  
Milpitas, CA 95035  
TEL: (408) 934-7500  
FAX: (408) 935-7600

Sipex Corporation reserves the right to make changes to any products described herein. Sipex does not assume any liability arising out of the application or use of any product or circuit described herein; neither does it convey any license under its patent rights nor the rights of others.