

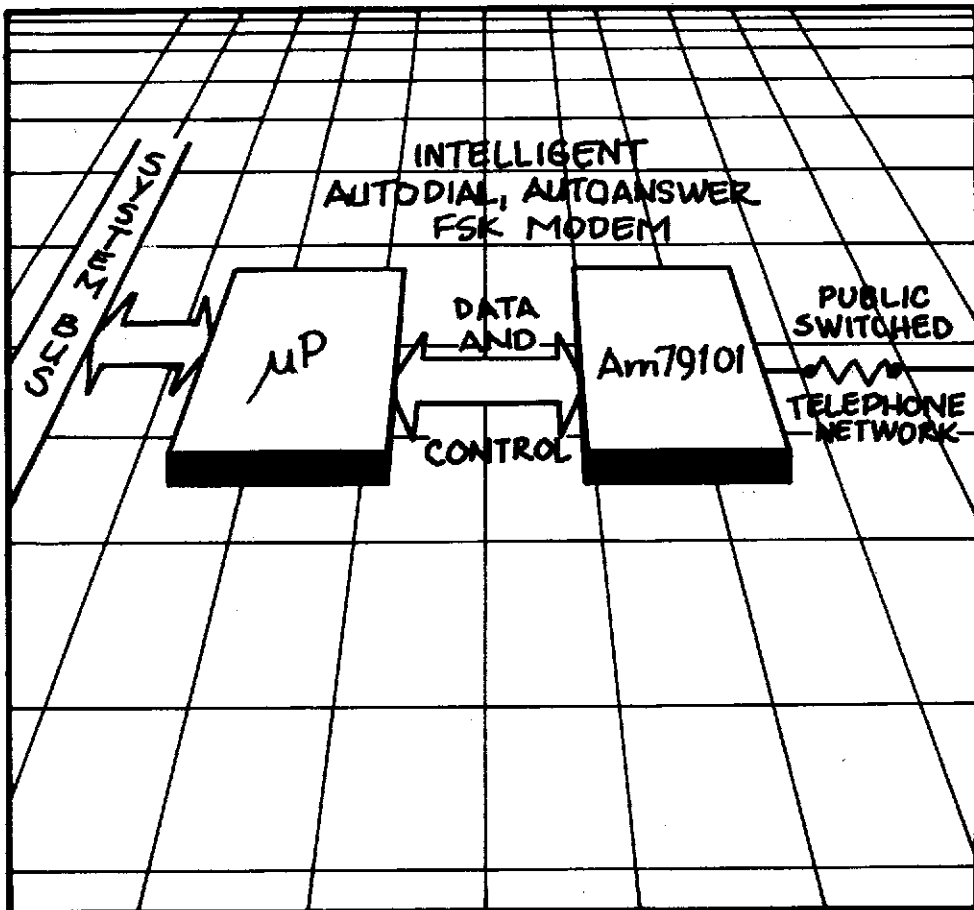

WORLD CHIP™ FSK AUTODIAL MODEM

Preliminary Data Sheet

Advanced Micro Devices



Am79101 PRELIMINARY DATA SHEET

Am79101

FSK AUTODIAL MODEM

PRELIMINARY DATA SHEET

PRODUCT SPECIFICATION:
 THE Am79101 FSK AUTODIAL MODEM
 PRELIMINARY DATA SHEET

DECEMBER 1987

CONTENTS

DISTINCTIVE CHARACTERISTICS	5
GENERAL DESCRIPTION	6
ORDERING INFORMATION	8
PIN DESCRIPTION	9
Setup Controls	
Transmitter I/O	
Receiver I/O	
Miscellaneous	
FUNCTIONAL DESCRIPTION	18
Transmitter	
Receiver	
Interface Control	
CALL ESTABLISHMENT	23
Call Progress Tone Detection (CPTD)	
Dual-Tone Multi-Frequency (DTMF) Tone Generation	
Answer Tone Detection	
Answer Tone Generation	
DATA TRANSMISSION	30
Full-Duplex	
Half-Duplex	
Main Channel	
Soft Turn-Off	
Squelch	
Back Channel	
DATA RECEPTION	32
Full-Duplex	
Half-Duplex	
LOOPBACK	32
CLOCK GENERATION	43
RESET MODES	44
POWER SUPPLY	45

PRELIMINARY AM79101 DATA SHEET

ABSOLUTE MAXIMUM RATINGS	46
DC CHARACTERISTICS	47
SWITCHING CHARACTERISTICS	49
PERFORMANCE	50
APPLICATIONS	52
PHYSICAL DIMENSIONS	55

Table of Figures

Block Diagram	6
Connection Diagrams	7
Figure 1. Loopback Configurations	18
Figure 2. Transmitter Block Diagram	20
Figure 3. Receiver Block Diagram	20
Figure 4. Full-Duplex Channel Assignments	22
Figure 5. Half-Duplex Channel Assignments	22
Figure 6a. Autodial Flowchart	26
Figure 6b. Autodial Timings	27
Figure 7a. Autoanswer Flowchart	28
Figure 7b. Autoanswer Timings	29
Figure 8a. Transmit Main Channel State Diagram	34
Figure 8b. Transmit Back Channel State Diagram	35
Figure 9. Receiver Main/Back Channel State Diagram	36
Figure 10. Bell 202 5 bps Handshake Timing	39
Figure 11. CCITT V.23 Handshake Timing	40
Figure 12. CCITT V.23 STO & Bell 202 150 bps Handshake Timing	41
Figure 13. Bell 103/CCITT V.21 Handshake Timing	42
Figure 14a. Clock Generation	43
Figure 14b. External Clock	44
Figure 15a. Automatic Reset	44
Figure 15b. Reset Timing Diagrams	45
Figure 16. Mode Setup	45
Figure 17. Power-Supply Connections.	46
Figure 18. Nominal Bit Error Rate	51
Figure 19. Out-of-Band Transmitter Energy	52
Figure 20. 300 bps Full-Duplex Modem	53
Figure 21. 1200 bps Half-Duplex Modem	54
Figure 22. Data Access Arrangement	55
Table 1a. Mode Controls in the Data Mode (DA/ \overline{CA} =HIGH)	15
Table 1b. Mode Controls in the Call Mode (DA/ \overline{CA} =LOW)	17
Table 2. Initial Conditions	21
Table 3. Frequency Parameters	23
Table 4. DTMF Tone Combinations	29
Table 5. Timing Parameters	37
Table 6. Clocking Parameters	44

copyright 1987 Advanced Micro Devices, Inc.

Advanced Micro Devices reserves the right to make changes in its products without notice in order to improve design or performance characteristics. The performance characteristics listed in this data sheet are guaranteed by specific tests, correlated testing, guard banding, design and other practices common to the industry. For specific testing details contact your local AMD sales representative. The company assumes no responsibility for the use of any circuits described herein.

Am79101

FSK AUTODIAL MODEM
WORLD-CHIP™

DISTINCTIVE CHARACTERISTICS

- o Bell 103, 113, 108 and CCITT V.21 compatible at 300 bps full-duplex
- o Bell 202 and CCITT V.23 compatible at 1200 bps half-duplex with up to 150 bps back channel (CCITT V.23 modes with optional soft carrier turn-off feature)
- o Single-chip digital signal processor
- o Autodial support
 - Dual Tone Multi-Frequency (DTMF) Tone Generation
 - Call Progress Tone Detection
 - Answer Tone Detection
- o Integral 4-to-2 wire hybrid
- o Public Switched Telephone Network (PSTN) response times
- o Serial RS-232C/CCITT V.24-type handshake interface and protocol

GENERAL DESCRIPTION

The Am79101 World-Chip is a single-chip asynchronous Frequency Shift Keying (FSK) modem that is compatible with the applicable Bell and CCITT-recommended standards for 103/113/108, 202, V.21 and V.23-type modems. All modulation, demodulation, filtering, analog-to-digital and digital-to-analog functions are provided on-chip.

Using the features described here, an intelligent Autodial, Autoanswer FSK modem may be implemented with only an Am79101 single-chip under the control of a host microprocessor and a Data Access Arrangement (DAA) circuit.

The modem operates in a serial asynchronous mode; the serial interface supports the RS-232C/CCITT V.24-type handshake signals at TTL levels.

The modem analog interface provides an internal hybrid for the 4-to-2 wire conversion. Auxiliary functions performed within the Am79101 include:

- Autodial support with DTMF generation and Call Progress Tone Detection.
- Answer Tone Detection (Bell and CCITT).
- Autoanswer support.
- Analog loopback support.

The Am79101 is housed in a 28-pin plastic leaded chip carrier as well as 28-pin plastic and ceramic dual-in-line packages.

Connection to the telephone network may be via a DAA or an acoustic coupler. All digital I/O signals are TTL-compatible (except the external clock and RESET signals) and the circuit operates from +5 Volts.

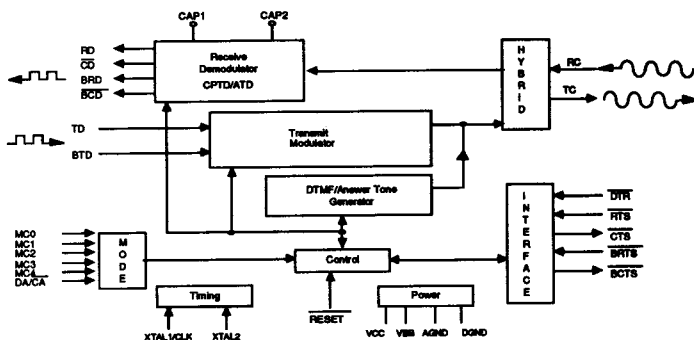

Am79101 Block Diagram

00028-1

CONNECTION DIAGRAMS
Top View

DIP

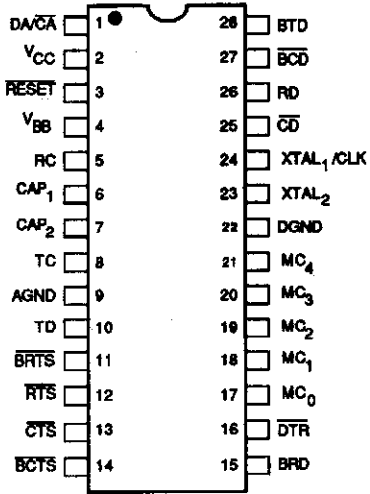

PLCC

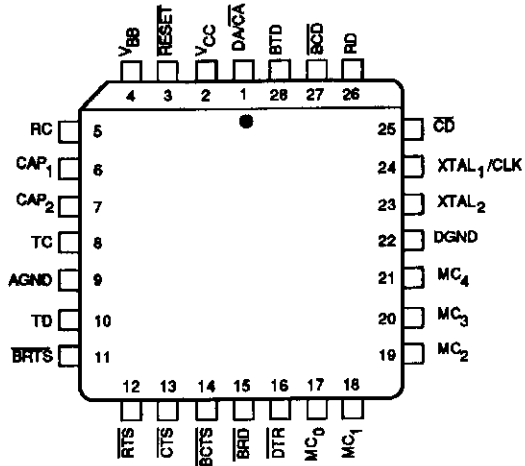

09E22A-2

Note: Pin 1 is marked for orientation.

ORDERING INFORMATION

Standard Products

AMD products are available in several packages and operating ranges. The order number (valid combination) is formed by a combination of the following:

- a. Device number
- b. Speed option (if applicable)
- c. Package type
- d. Temperature range
- e. Optional processing

Am79101

D

C

B

- e. Optional Processing
Blank = Standard processing
B = Burn-in

- d. Temperature Range
C = Commercial (0°C to +70°C)
I = Industrial (-40°C to +85°C)
E = Extended (-55°C to +125°C)

- c. Package Type
D = 28-Pin Ceramic DIP (CD 028)
P = 28-Pin Plastic DIP (PD 028)
J = 28-Pin PLCC (PL 028)

- a. AMD Device Type
FSK Modem
- b. Speed Option
Not Applicable

Valid Combinations	
Am79101	DC, DCB, DI, DIB, PC, DE, DEB, JC

Valid Combinations

Valid Combinations list configurations planned to be supported in volume for this device. Consult the local AMD sales office to confirm availability of specific valid combinations, to check on newly released valid combinations, and to obtain additional data on AMD's standard military grade products.

PIN DESCRIPTION

All digital inputs and outputs are TTL-compatible unless otherwise noted.

SETUP CONTROLS

DA/CA Data/Call (Input)

This input selects the Data Mode (DA/CA=HIGH) or the Call Mode (DA/CA=LOW). In the Data Mode, the Am79101 operates as a modem, using other setup and handshake inputs. Data Mode is the initial condition by default.

To enter the Call Mode, DA/CA is brought to a LOW while DTR is HIGH and MC pins are set to a valid mode (i.e., not reserved mode). Once in the Call Mode, DTR is set LOW. MC inputs and RTS will determine the generation of either DTMF or answer tones, and the detection of call progress tones or answer tones. To re-enter the Data Mode, DA/CA is returned to a HIGH during a valid modem mode.

DTR Data Terminal Ready (Input)

A LOW level on this input indicates the data terminal is ready to send and/or receive data via the modem. This signal is gated with all other TTL inputs and outputs so that a LOW level enables these signals as well as the internal control logic. A HIGH disables all TTL I/O pins and the internal logic.

When DTR is HIGH, the modem handshake state machine is reset to initial conditions. This is the only way to reset the state machine, and must be done after power-up. The state machine does not automatically power up to a known state. If DTR is permanently enabled (LOW), the state machine will simply run from wherever it powers-up. This can result in abnormal behavior such as an unusually short RTS-CTS delay due to lack of DTR initialization.

To change the modem mode when powered-up, use the following sequence: (See Figure 16)

1. Set $\overline{\text{DTR}}$ HIGH
2. Change MC inputs to desired configuration
3. Wait at least 100 microseconds
4. Set $\overline{\text{DTR}}$ LOW

The MC inputs perform some hardware functions and are also sampled periodically by the state machine. If the $\overline{\text{MC}}$ inputs are changed without re-initialization using $\overline{\text{DTR}}$, the state machine will not completely change to the new mode. In the Call Mode, $\overline{\text{DTR}}$ does not have to be changed when going from one DTMF digit to another.

MC₀-MC₄ Mode Controls (Inputs)

In the Data Mode, the MC inputs specify one of the 25 available modem configurations as listed in Table 1a. Included are Bell 103/202, CCITT V.21/V.23 with various options like equalizer, 150 bps back channel, soft turn-off and loopback.

The loopback modes set the signal processing frequency band of the receiver to that of the transmitter. The user must connect TC to RC for analog loopback, and RD to TD for digital loopback as shown in Figure 1.

In the Call Mode, the MC inputs select generation of DTMF or answer tones, or detection of call progress tones or answer tones, as listed in Table 1b.

None of the reserved modes should be used.

TRANSMITTER I/O

$\overline{\text{BCTS}}$ Back Clear To Send (Output)

This line is equivalent to $\overline{\text{CTS}}$ for the main channel, except that it applies only to the back channel. $\overline{\text{BCTS}}$ is meaningful only when a V.23 mode or 202 150bps (or 75bps) back channel mode is selected by MC₀-MC₄. This signal is not used in the 202 5bps back channel mode.

BRTS Back Request To Send (Input)

Since the 1200bps modem configurations, Bell 202 and CCITT V.23, permit only half-duplex operation over 2-wire lines, a low baud rate back channel is provided for simultaneous transmission in the reverse direction. BRTS is directly equivalent to main channel RTS, except that it applies only to the back channel. Note that since the modem contains a single transmitter, RTS and BRTS should not be asserted simultaneously. BRTS is meaningful only when a 202 or V.23 mode is selected by MC₀-MC₄. In all other modes, it is ignored.

For the V.23 modes and the 202 150bps (or 75bps) back channel mode, the frequency appearing at TC is determined by a Mark or Space at BTD. For the 202 5bps back channel mode, a frequency of 387 Hz appears at TC when BRTS is LOW and BTD is HIGH. No energy (0.0 Volts) appears at TC when BRTS is HIGH. BTD should be held HIGH in this mode. BRTS then, is equivalent to the transmitted data. BRTS is the Secondary Request-to-Send for 202 S/T modems, or the Supervisory Transmitted Data for 202 C/D modems.

BTD Back Transmitted Data (Input)

This line is equivalent to TD for the main channel, except that it applies only to the back channel. BTD is meaningful only when a 202 or V.23 mode is selected by MC₀-MC₄. For 202 5bps back channel transmission of On/Off keying, BTD should be set HIGH.

CTS Clear To Send (Output)

This output goes LOW at the end of a delay (t_{RCON}) initiated when RTS goes LOW. Actual data to be transmitted should not be presented to TD until a LOW is indicated on CTS. This gives the receiving modem (on the other end of the phone line) enough time to recognize a valid carrier signal before data is transmitted. Normally the user should force TD HIGH whenever CTS is HIGH so a Mark will be sent during the t_{RCON} time. CTS goes HIGH at the end of a delay initiated when RTS goes HIGH (t_{RCOFF}). CTS will never be LOW when DTR is HIGH.

RTS Request To Send (Input)

A LOW on this input instructs the modem to enter transmit mode. This input must remain LOW for the duration of data transmission. This signal has no effect if DTR is HIGH (disabled). A HIGH level on this input turns off the transmitter.

In the Call Mode, $\overline{\text{RTS}}$ also controls the transmitter. When RTS is LOW, the tone specified by the MC pins will be transmitted. A HIGH level will turn off the tone. During Answer Tone Detection and Call Progress Tone Detection, RTS should be HIGH.

TC Transmitted Carrier (Output, Non-TTL-Compatible)

This analog output is the modulated carrier to be sent over the phone line. Its frequency changes according to the data at TD or BTD.

TD Transmitted Data (Input)

Data bits to be transmitted are presented to this input serially; HIGH (Mark) corresponds to logic 1 and LOW (Space) corresponds to logic 0. This input determines which frequency to appear at any instant at TC (See Table 3). No signal appears at TC unless $\overline{\text{DTR}}$ is LOW and RTS is LOW.

RECEIVER I/O

$\overline{\text{BCD}}$ Back Carrier Detect (Output)

This line is equivalent to $\overline{\text{CD}}$ for the main channel, except that it applies only to the back channel. $\overline{\text{BCD}}$ is meaningful only when a 202 or V.23 mode is selected by $\text{MC}_0\text{-MC}_4$. For the V.23 or 202 150bps (or 75bps) back channel modes, $\overline{\text{BCD}}$ changes to LOW when either the Mark or Space frequency appears with sufficient level at RC.

For the 202 5bps back channel mode, $\overline{\text{BCD}}$ changes to LOW in response to a 387 Hz tone of sufficient level at RC. In this case $\overline{\text{BCD}}$ is equivalent to the signal, Secondary Received Line Signal Detector, for 202 S/T modems, or Supervisory Received Data for 202 C/D modems.

BRD Back Received Data (Output)

This line is equivalent to RD for the main channel, except that it applies only to the back channel. BRD is meaningful only for the V.23 or the 202 back channel modes. Under the following conditions this output is clamped HIGH:

1. V.21/103 modes
2. $\overline{\text{BCD}}$ HIGH
3. $\overline{\text{DTR}}$ HIGH
4. $\overline{\text{BRTS}}$ LOW and $\overline{\text{RTS}}$ HIGH in V.23 or 202 150 bps modes only
5. During Autoanswer sequence.

CD Carrier Detect (Output)

A LOW on this output indicates that a valid carrier signal is present at the receiver and has been present for at least the time t_{CDON} . A HIGH on this output signifies that no valid carrier is being received and has not been received for at least the time t_{CDOFF} . In the Data Mode, Carrier Detect looks for energy in the receive bandwidth. A carrier is considered valid when the signal level at RC is above a threshold limit V_{CDON} , and absent when the level is below V_{CDOFF} .

In the Call Mode, a \overline{CD} LOW output indicates a valid answer tone or call progress tone has been detected above the limit V_{CDON} . A \overline{CD} HIGH output indicates there is no energy above the V_{CDOFF} .

RC Received Carrier (Input, Non-TTL-Compatible)

This input is the analog signal received from the phone line. The modem extracts the information contained in this modulated carrier and converts it into a serial data stream at RD or BRD.

RD Received Data (Output)

Data bits demodulated from RC are available serially at this output; HIGH (Mark) indicates logic 1 and LOW (Space) indicates logic 0. Under the following conditions, this output is clamped HIGH because the data may be invalid:

1. When \overline{CD} is HIGH
2. During the internal squelch delay at half-duplex line turn-around (202 and V.23 modes only)
3. During soft carrier turn-off at half-duplex line turn-around (202 and V.23 soft turn-off modes only)
4. When \overline{DTR} is HIGH
5. When \overline{RTS} is LOW and \overline{BRTS} is HIGH in 202 and V.23 modes only
6. During Autoanswer sequence.

MISCELLANEOUS

AGND Analog Ground

CAP1, CAP2 (Non-TTL-Compatible)

These two pins are connection points for the external series capacitor-resistor required for proper operation of the on-chip analog-to-digital converter.

Recommended values are: C = 2000 pF $\pm 10\%$
R = 910 ohm $\pm 10\%$

DGND Digital Ground**RESET (Non-TTL-Compatible)**

This input signal is for a reset circuit which operates in either of two modes (refer to Figures 15a and 15b). The Am79101 should be reset upon initial application of power.

VBB -5 Volt Power Supply

VCC +5 Volt Power Supply

XTAL₁, XTAL₂ (Non-TTL-Compatible)

Master timing of the modem is provided by either a crystal connected to these two pins or an external clock inserted into XTAL₁. The value of the crystal or the external clock frequency must be 2.4576 MHz $\pm .01\%$.

Table 1a. Mode Controls in the Data Mode (DA/CA=HIGH)

MC ₄	MC ₃	MC ₂	MC ₁	MC ₀	Modem Modes
0	0	0	0	0	Bell 103 Originate 300 bps full-duplex
0	0	0	0	1	Bell 103 Answer 300 bps full-duplex
0	0	0	1	0	Bell 202 1200 bps half-duplex with 5 bps back channel
0	0	0	1	1	Bell 202 1200 bps with amplitude equalizer and 5 bps back channel
0	0	1	0	0	CCITT V.21 Originate 300 bps full- duplex
0	0	1	0	1	CCITT V.21 Answer 300 bps full-duplex
0	0	1	1	0	CCITT V.23 Mode 2 1200 bps half-duplex*
0	0	1	1	1	CCITT V.23 Mode 2 with amplitude equalizer 1200 bps half-duplex*
0	1	0	0	0	CCITT V.23 Mode 1 600 bps half-duplex*
0	1	0	0	1	Reserved
0	1	0	1	0	Bell 202 1200 bps with 150 bps back channel
0	1	0	1	1	Bell 202 1200 bps with amplitude equalizer and 150 bps back channel
0	1	1	0	0	CCITT V.23 Mode 1 600 bps with soft turn-off*
0	1	1	0	1	Reserved
0	1	1	1	0	CCITT V.23 Mode 2 1200 bps with soft turn-off*
0	1	1	1	1	CCITT V.23 Mode 2 1200 bps with amplitude equalizer and soft turn-off*

*Up to 150 bps back channel is available.

Note: Reserved modes should not be entered.

Table 1a. Mode Controls in the Data Mode (DA/CA = HIGH)
(Continued)

MC ₄	MC ₃	MC ₂	MC ₁	MC ₀	Modem Modes
1	0	0	0	0	Bell 103 Originate loopback
1	0	0	0	1	Bell 103 Answer loopback
1	0	0	1	0	Bell 202 main loopback
1	0	0	1	1	Bell 202 with amplitude equalizer loopback
1	0	1	0	0	CCITT V.21 Originate loopback
1	0	1	0	1	CCITT V.21 Answer loopback
1	0	1	1	0	CCITT V.23 Mode 2 main loopback
1	0	1	1	1	CCITT V.23 Mode 2 with amplitude equalizer loopback
1	1	0	0	0	CCITT V.23 Mode 1 main loopback
1	1	0	0	1	CCITT V.23 back loopback*
1	1	0	1	0	Bell 202 150 bps back loopback
1	1	0	1	1	Reserved
1	1	1	0	0	
1	1	1	0	1	
1	1	1	1	0	
1	1	1	1	1	

* Up to 150 bps back channel is available.

Note: Reserved modes should not be entered.

Table 1b. Mode Controls in the Call Mode (DA/CA=LOW)

MC ₄	MC ₃	MC ₂	MC ₁	MC ₀	Autodial/Autoanswer Function
0	0	0	0	0	DTMF 0 or Answer Tone Detection
0	0	0	0	1	DTMF 1
0	0	0	1	0	DTMF 2
0	0	0	1	1	DTMF 3
0	0	1	0	0	DTMF 4
0	0	1	0	1	DTMF 5
0	0	1	1	0	DTMF 6
0	0	1	1	1	DTMF 7
0	1	0	0	0	DTMF 8
0	1	0	0	1	DTMF 9
0	1	0	1	0	DTMF *
0	1	0	1	1	DTMF #
0	1	1	0	0	Bell 103 Answer Tone
0	1	1	0	1	Bell 202 Answer Tone
0	1	1	1	0	V.21 or V.23 Answer Tone
0	1	1	1	1	Call Progress Tone Detection
1	X	X	X	X	Reserved

Note: Reserved modes should not be entered.

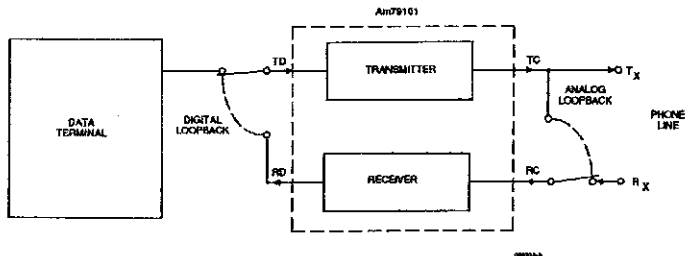

Figure 1. Loopback Configurations

FUNCTIONAL DESCRIPTION

The modem consists of three main sections shown in the Am79101 block diagram - Transmitter, Receiver, and Interface Control.

Transmitter (Modulator)

In the Data Mode, the transmitter, shown in Figure 2, receives binary digital data from a source such as a UART and converts the data to an analog signal using Frequency Shift Keying (FSK) modulation. This analog signal is applied to the phone line through a DAA or an acoustic coupler. FSK is a modulation technique which encodes one bit per baud. A logic 1 applied to the TRANSMITTED DATA (TD) input causes a sine wave at a given frequency to appear at the analog TRANSMITTED CARRIER (TC) output. A logic 0 applied to TD causes a sine wave of a different frequency to appear at TC. As the data at TD switches between logic 1 and 0, TC switches between the two frequencies. In the Am79101 this switching between frequencies is phase continuous. The frequencies themselves are digitally synthesized sine functions.

The frequencies for each modem configuration available in the Am79101 are listed in Table 3.

The process of switching between two frequencies (as in FSK) generates energy at many more frequencies than the two used in the modulation. All the transmitted information can be recovered from a frequency band B Hz wide, where B is the bit rate or maximum rate of change of the digital data at TD. This band is centered about a frequency, f_c ,

$$\text{where } f_c = (f_1 + f_2)/2$$

$$(f_1 = \text{lower of two FSK frequencies})$$

$$(f_2 = \text{higher of two FSK frequencies})$$

In addition to this primary information band, there are side bands containing redundant information. It is desirable to attenuate these bands for two reasons:

1. The phone companies have specifications on the amount of energy allowed in certain frequency bands on the line.
2. If two independent information channels are present simultaneously on the line (e.g., 300 bps full-duplex or 1200 bps half-duplex with back channel), the redundant transmitter components may fall in the frequency band of the local receiver channel and interfere with detection. In the Am79101 these redundant and undesirable components are attenuated by digital bandpass filters.

Following the digital bandpass filters, the filtered FSK signal is converted to an analog signal by an on-chip Digital-to-Analog Converter (DAC) operating at a high sampling rate. This analog FSK signal is made smooth by a simple on-chip analog low-pass filter.

In the Call Mode, the sine synthesizer generates the DTMF or answer tones as specified by the MC inputs. These tones are then processed like the FSK signal and eventually appear at TC. Table 4 shows the DTMF tone combinations.

Receiver (Demodulator)

A simplified block diagram of the Am79101 FSK receiver is shown in Figure 3. Data transmitted from a remote-site modem over the phone line is a FSK-modulated analog carrier. This carrier is applied to the RECEIVED CARRIER (RC) pin via a DAA or an acoustic coupler. The first stage of the demodulator is a simple on-chip analog low-pass anti-alias filter. The output of this is converted into digital form and filtered by digital bandpass filters to improve the signal-to-noise ratio and reject other independent channel frequencies associated with the phone line in the case of full-duplex configuration. In the Data Mode, the bandpass-filtered output is digitally demodulated to recover the binary data to appear at the RECEIVED DATA (RD) pin. A Carrier Detect signal (\overline{CD}) is also digitally extracted from the received line carrier to indicate valid data.

In the Call Mode, the MC inputs select the proper digital bandpass filters to detect answer tones or call progress tones at RC. Presence of a valid tone will be indicated by \overline{CD} .

The on-chip hybrid provides the analog interface which communicates TC and RC directly over two wires to and from the telephone line via a DAA.

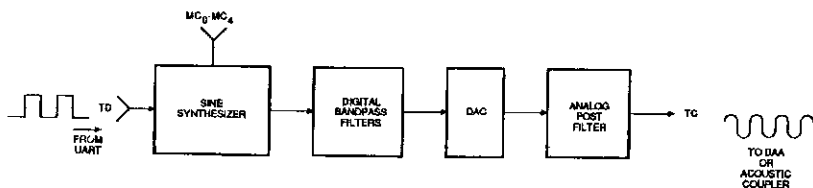

000324-4

Figure 2. Transmitter Block Diagram

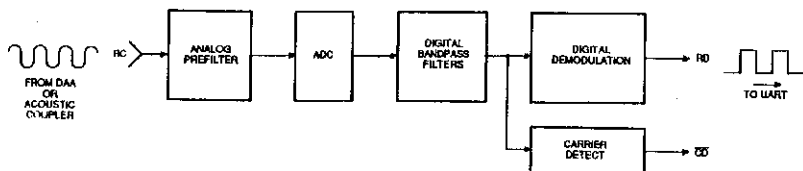

000324-4

Figure 3. Receiver Block Diagram

Interface Control

This section controls the handshaking between the modem and the local terminal. It consists primarily of delay-generation counters, two state machines for controlling transmission and reception, and mode-control-decode logic. Proper transmit frequencies and transmit/receive filters are selected according to the specified modem type or function in the Data or Call Mode. Inputs to and outputs from this section are as follows:

DATA/CALL

MC₀-MC₄

DATA TERMINAL READY

REQUEST TO SEND (Main and Back)

CLEAR TO SEND (Main and Back)

CARRIER DETECT (Main and Back)

RESET

Internal logic clamps the handshake signals to different levels under certain conditions (e.g., initial conditions).

When Bell 103/113 and V.21 modem configurations are selected, the back channel signals are non-functional.

Figures 8a through 9 depict the sequencing of the two state machines. State machine 1 implements main or back channel transmission. State machine 2 implements reception on main or back channel. Table 5 lists the timing parameters, and Figures 10 through 13 show the handshake timing diagrams for the various modem modes.

The state machine powers-on to the state labeled INITIAL CONDITIONS. Handshake signals are set to or assumed to be the levels listed in Table 2. The machine then waits for DATA TERMINAL READY (DTR) to go LOW. Whenever DTR is changed from LOW to HIGH, each state machine and external signals return to the initial conditions within 25 microseconds. After DTR is set LOW, the Am79101 becomes operational as a modem and the state machines proceed as depicted in the flowcharts.

The definitions of the terms full-duplex and half-duplex used in these flowcharts are depicted in Figures 4 and 5. Full-duplex applies to all 103/113 and V.21 modes. Half-duplex applies to 202 and V.23, both main and back channels.

Full-Duplex: Data can be transmitted and received simultaneously at 300 bps. Two independent 300 Hz channels are frequency multiplexed into the 3000 Hz bandwidth of the phone line. The Am79101 configurations for the Bell 103/113 and CCITT V.21 can be operated full-duplex.

Half-Duplex: In half-duplex with back channel, the Am79101 may transmit at 1200/600 bps and receive at 5/75/150 bps. Alternately it may transmit at 5/75/150 bps and receive at 1200/600 bps. Examples are Bell 202 and CCITT V.23.

Table 2. Initial Conditions

Data/Call (DA/CA)	HIGH (Data)
Data Terminal Ready (DTR)	HIGH
Request-to-Send (RTS)	HIGH
Clear-to-Send (CTS)	HIGH
Transmitted Data (TD)	Ignored
Back Channel Request-to-Send (BRTS)	HIGH
Back Channel Clear-to-Send (BCTS)	HIGH
Back Channel Transmitted Data (BTD)	Ignored
Carrier Detect (CD)	HIGH
Received Data (RD)	HIGH
Back Channel Carrier Detect (BCD)	HIGH
Back Channel Received Data (BRD)	HIGH

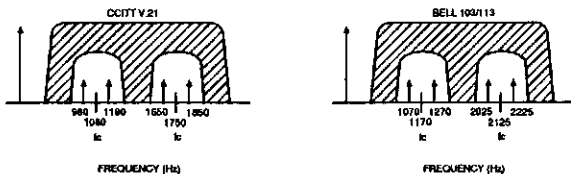

0833A-4

Figure 4. Full-Duplex Channel Assignments

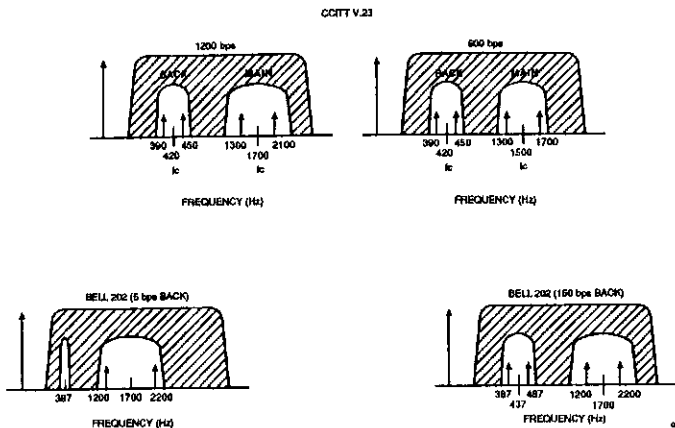

0833A-7

Figure 5. Half-Duplex Channel Assignments

Table 3. Frequency Parameters

Modem Mode	Baud Rate (bps)	Duplex	Transmit Frequency		Receive Frequency	
			Space (Hz)	Mark (Hz)	Space (Hz)	Mark (Hz)
Bell 103 Originate	300	Full	1070	1270	2025	2225
Bell 103 Answer	300	Full	2025	2225	1070	1270
CCITT V.21 Originate	300	Full	1180	980	1850	1650
CCITT V.21 Answer	300	Full	1850	1650	1180	980
CCITT V.23 Mode 1	600	Half	1700	1300	1700	1300
CCITT V.23 Mode 2	1200	Half	2100	1300	2100	1300
CCITT V.23 Mode 2 Equalized	1200	Half	2100	1300	2100	1300
Bell 202	1200	Half	2200	1200	2200	1200
Bell 202 Equalized	1200	Half	2200	1200	2200	1200
CCITT V.23 Back	75/150	-	450	390	450	390
Bell 202 5 bps Back	5	-	*	*	**	**
Bell 202 150bps Back	150	-	487	387	487	387
All Bell 202 modes and V.23 Soft Turn-off modes	Soft Turn-off Tone = 900 Hz					

* (BRTS LOW) and (BTD HIGH): 387 Hz at TC.

* (BRTS HIGH) or (BTD LOW): 0 Volts at TC.

** 387 Hz at RC: BCD LOW.

** No 387 Hz at RC: BCD HIGH.

Call Establishment

The Am79101 supports Autodial and Autoanswer with the following features:

Call Progress Tone Detection (CPTD)
 Dual Tone Multi-Frequency (DTMF) Tone Generation
 Answer Tone Detection (ATD)
 Answer Tone Generation (ATG)

First, the Mode Control (MC₀-MC₄) pins are used to set up the modem mode. Next, the Call Mode is entered by setting DA/CA=LOW (see pin description). DTR is then set LOW once at the beginning of the Autodial or Autoanswer sequence. $\overline{\text{RTS}}$ remains HIGH except when tones are required to be transmitted. Now the MC pins can be used to select the above Autodial/Autoanswer features, as defined in Table 1b.

Autodial begins by using the CPTD function to detect the proper dial tone from the central office. The DTMF digit to be dialed is then input to the MC pins and the transmitter generates the corresponding DTMF tones at the TC pin. After the last digit is sent, CPTD is used again to detect the ringback signal. Following the detection of ringback, the ATD feature can be used to detect the answer tone from the called modem. Following detection of the correct answer tone, data transfer can now begin. Figures 6a and 6b show the Autodial flowchart and timings.

As a called modem, the Am79101 will be placed in the Call Mode by the external microprocessor which receives a ring indication signal from the DAA. Autoanswer begins by using ATG. Figures 7a and 7b show the Autoanswer flowchart and timings.

Call Progress Tone Detection (CPTD)

The CPTD filter passes call progress tones from all the major Post Telephone and Telegraphs (PTTs). The cadences (temporal patterns) of CD will identify the following signals:

- Primary Dial Tone
- Secondary Dial Tone
- Ringback Signal
- Network Busy Signal
- Busy Signal

Each country's PTT may have different requirements for the cadences of these call progress tones.

Dual Tone Multi-Frequency (DTMF) Tone Generation

The Am79101 transmitter can generate the basic 3 x 4 matrix, as shown in Table 4. According to the Bell specifications, the minimum duration for the DTMF digit is 50 ms. The minimum interdigit interval (silence) is 45 ms. The minimum time from the beginning of one DTMF digit to the next is 100 ms. It is common practice to extend the DTMF digit duration to insure detection by the central office.

Once in the Call Mode, $\overline{\text{RTS}}$ controls the duration of the DTMF tone. With $\overline{\text{DTR}}=\text{LOW}$ and the desired digit applied to the MC pins, setting $\overline{\text{RTS}}=\text{LOW}$ will generate the DTMF tone at TC until

$\overline{\text{RTS}}$ is set HIGH. The user has complete control of the DTMF tone duration and the interdigit interval. Inputs to the MC pins should be changed while $\overline{\text{RTS}}$ is HIGH and $\overline{\text{DTR}}$ is LOW.

Answer Tone Detection (ATD)

The Am79101 receiver can detect answer tones for the Bell 103, 202, and CCITT V.21/V.23 modes. $\overline{\text{CD}}=\text{LOW}$ indicates the presence of a valid answer tone. RD distinguishes between the three answer tones as shown below. This feature allows mode matching with the remote modem. In the CCITT V.21/V.23 modes, X at RD indicates toggling between HIGH and LOW.

<u>Modem Mode</u>	<u>Answer Tone Frequency (Hz)</u>	<u>$\overline{\text{CD}}$</u>	<u>RD</u>
Bell 103	2225	LOW	HIGH
Bell 202	2025	LOW	LOW
CCITT V.21/V.23	2100	LOW	X

The Carrier Detect Call thresholds (VCDCON , VCDCOFF) for valid answer tone detection are internally set to be higher than those in the Data Mode. This eliminates the need for an external attenuator in the Call Mode to prevent noise from being decoded as an answer tone.

Answer Tone Generation (ATG)

Answer tones are generated according to the modem mode selected, as listed in the ATD section. $\overline{\text{RTS}}=\text{LOW}$ controls the answer tone duration and $\overline{\text{RTS}}=\text{HIGH}$ controls the silence intervals. Silence interval before the answer tone is required by various governmental agencies for billing delay purposes.

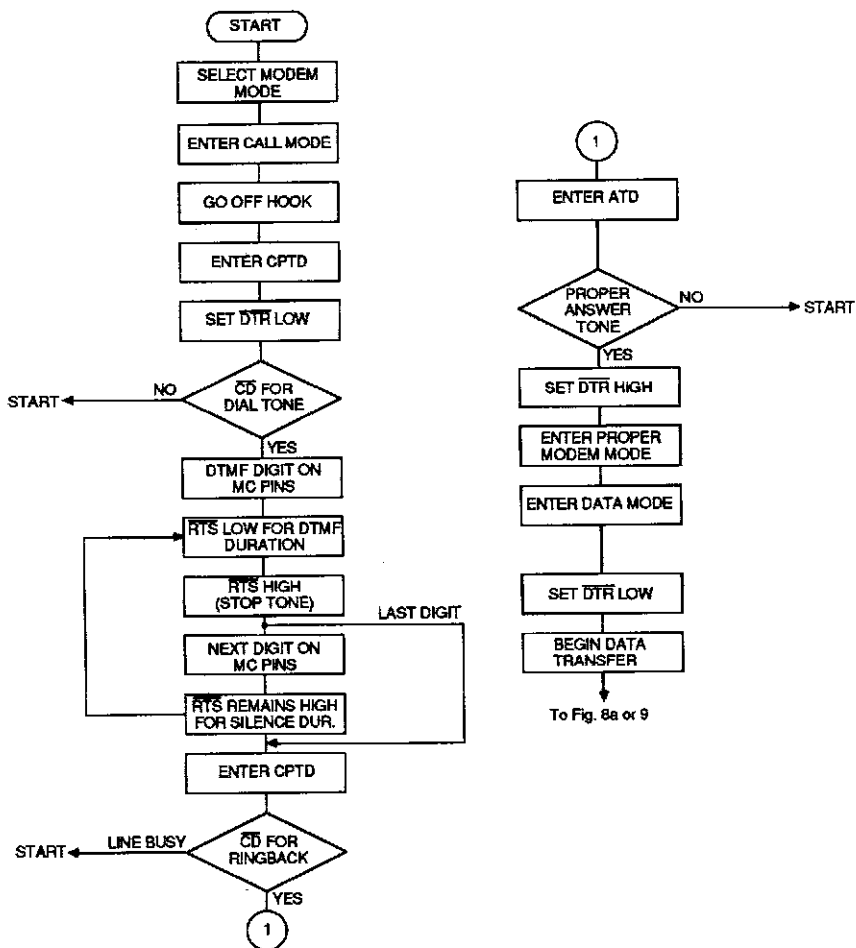

09833A-5

Figure 6a. Autodial Flowchart

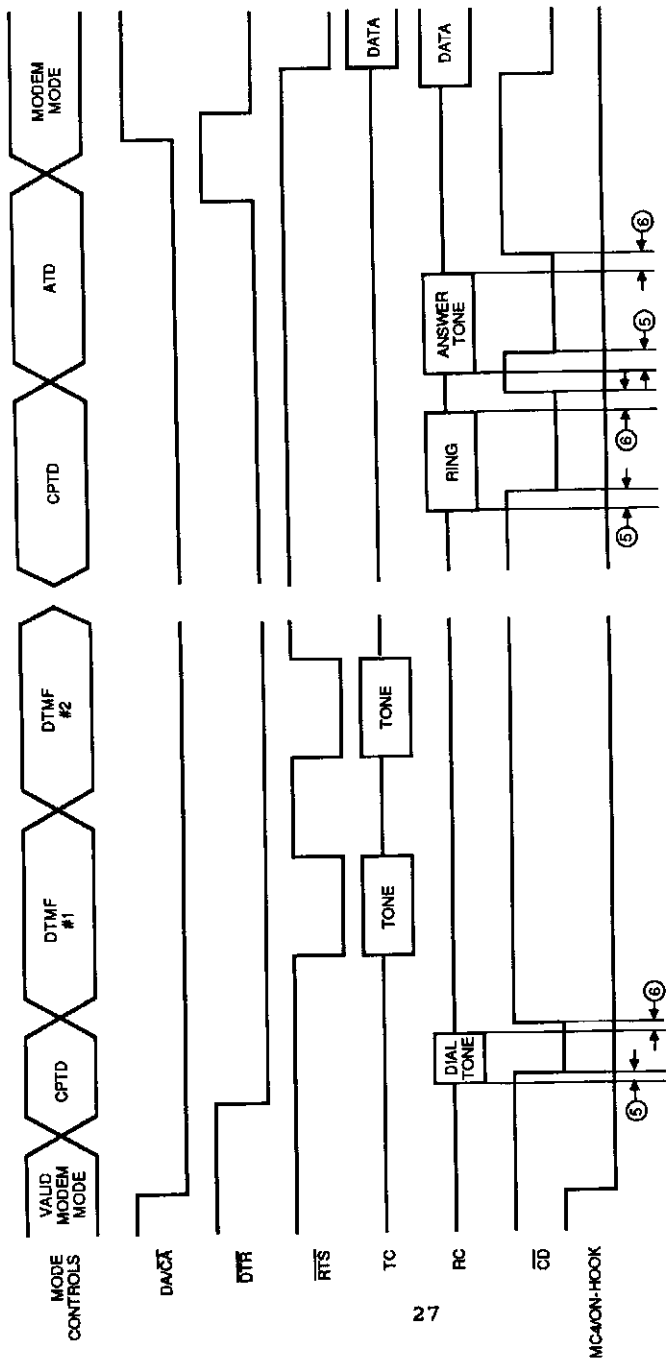

0M23A-9

Figure 6b. Autodial Timings

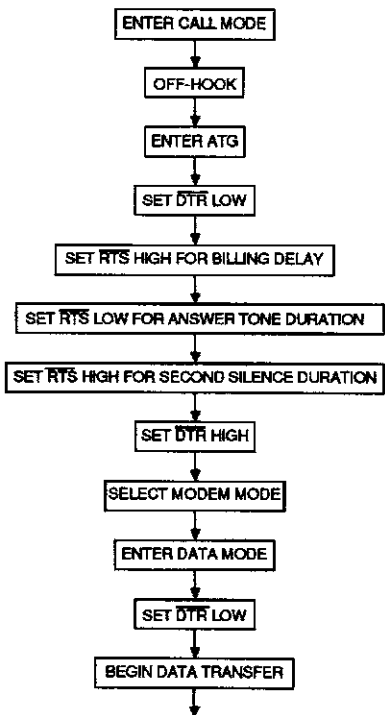

To Fig. 8a or 9

00833A-10

Figure 7a. Autoanswer Flowchart

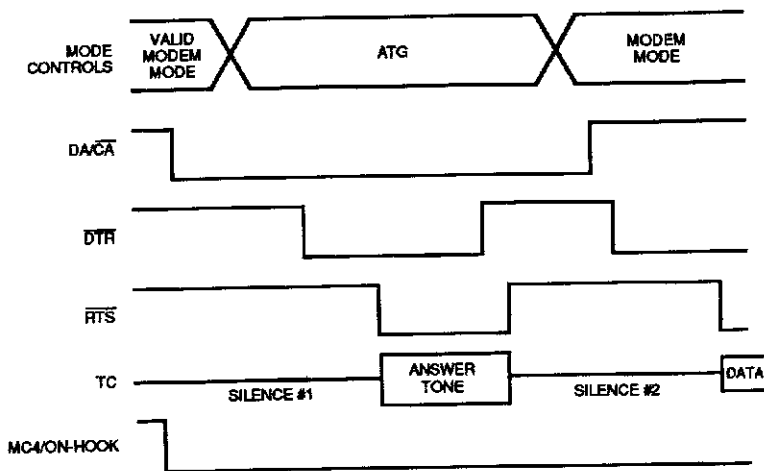

Figure 7b. Autoanswer Timings

Table 4. DTMF Tone Combinations

		High-Group Frequencies (Hz)		
		1209	1336	1477
Low-Group Frequencies (Hz)	697	1	2	3
	770	4	5	6
	852	7	8	9
	941	*	0	#

DATA TRANSMISSION*

Full-Duplex

Following call establishment, full-duplex data transmission can be started by either the called or calling modem. If the connection has been established and the modem is looping through point A in Figure 8a, it no longer matters which is the called and which is the calling modem. Data transmission is initiated by setting REQUEST TO SEND (RTS) LOW. At this time the TRANSMITTED DATA (TD) input will be released and a modulated carrier can appear at the TRANSMITTED CARRIER (TC) output. Following a delay, t_{RCON} , CLEAR TO SEND (CTS) changes to LOW. At this time, data may be transmitted through TD. It is common protocol for the user to always present a Mark at TD before RTS is asserted and during the t_{RCON} delay.

Data transmission continues until RTS is set HIGH. Following a short delay, t_{ROFF} , CTS changes to HIGH. As soon as RTS goes HIGH, TD is ignored and TC is set to 0.0 Volts (silence). After CTS changes to HIGH, the state machine returns to point A in Figure 8a.

Half-Duplex

When a half-duplex mode is selected (202 or V.23), data transmission can be either on the main channel at 1200/600 bps or on the back channel at 5/75/150 bps. In normal half-duplex operation a single modem is either transmitting on the main and receiving on the back channel or vice-versa. In the Am79101, control of the transmitter and receiver filters to the proper channel is performed by RTS. When RTS is asserted, the transmitter filters and synthesizer are set to transmit on the main channel; the receiver filters are set to receive on the back channel. Therefore, whenever RTS is LOW, BRTS should not be asserted since the transmitter cannot be used for the back channel. When RTS is HIGH and a half-duplex mode is selected, the transmitter filters and synthesizer are set to the back channel; the receiver filters are set to the main channel. If RTS and BRTS are asserted simultaneously, RTS will take precedence. However, if BRTS is asserted before RTS and the back channel data transmission sequence has been entered (Figure 8b), RTS will be ignored until BRTS is set HIGH.

The state machine sequences for main and back channel transmission differ slightly and are depicted in Figures 8a and 8b. Assume the state machine is idling through point A in Figure 8a.

* All timing delays are listed in Table 5.

Main Channel

This transmission sequence is entered if a 202 or V.23 mode is selected and RTS is asserted. Since the receiver is now forced to the back channel the RECEIVED DATA (RD) signal is clamped to a Mark, and the CARRIER DETECT (CD) signal is clamped HIGH. The TRANSMITTED DATA (TD) input is released and a carrier appears at the TRANSMITTED CARRIER (TC) output which follows the Mark/Space applied to TD. RTS going LOW initiates a delay, t_{RCON} , at the end of which the CLEAR TO SEND (CTS) output goes LOW. When CTS goes LOW, data may be transmitted through TD. Data transmission continues until RTS is set HIGH. At this time several events are initiated. First a delay, t_{RCOFF} , is initiated at the end of which CTS goes HIGH. TD is ignored as soon as RTS goes HIGH. If a 202 mode or V.23 soft turn-off mode is selected, a soft turn-off tone appears at TC for a time, t_{STO} , followed by silence (0.0 Volts). For both 202 and V.23 modes, a squelch period, t_{SQ} , is initiated when RTS goes HIGH. During this period the CD output is clamped HIGH, forcing the RD output to a Mark condition. The squelch period begins as soon as RTS goes HIGH and thus overlaps both t_{RCOFF} and t_{STO} . At the end of the squelch period, the state machine returns to the idle loop at point A in Figure 8a.

The reasons for squelch and soft turn-off are as follows:

Soft turn-off: When RTS goes HIGH at the end of a message, transients occur which may cause spurious Space signals to be received at the remote modem. During soft turn-off the modem transmits a soft carrier frequency for a period, t_{STO} , after RTS goes HIGH. This results in a steady Mark on the RECEIVED DATA (RD) line of the remote modem.

Squelch: The local receiver must be turned off after RTS is HIGH, until the start of carrier detect, so that line transients are not demodulated. The process of disabling the receiver after RTS goes HIGH is called squelching.

Back Channel

This transmission sequence, shown in Figure 8b, is entered if a 202 or V.23 mode is selected, RTS is HIGH, and BRTS is asserted. The BACK CARRIER DETECT (BCD) output is forced HIGH and the BACK RECEIVED DATA (BRD) output is clamped to a Mark. The BACK TRANSMITTED DATA (BTD) input is released and a carrier appears at the TC output which follows the Mark/Space applied to BTD. Setting BRTS LOW initiates a delay, t_{BRCON} , at the end of which the BACK CLEAR TO SEND (BCTS) output goes LOW. When BCTS goes LOW data may be transmitted through BTD. Data transmission continues until BRTS is set HIGH. BTD is immediately ignored and TC is silenced (set to 0.0 Volts). Following a short delay, t_{BRCOFF} , BCTS goes HIGH. The signals BCD and BRD are released and the state machine returns to idle at point A of Figure 8a. In 202 5 bps back channel mode, BTD

should be tied HIGH. Then $\overline{\text{BRTS}}$ controls the On/Off keying modulation. When $\overline{\text{BRTS}}$ is LOW, a 387 Hz tone appears at TC; when $\overline{\text{BRTS}}$ is HIGH, 0.0 Volts appear at TC.

DATA RECEPTION*

Data reception is controlled by state machine 2 and depicted in Figure 9. At power-on, the machine enters initial conditions and remains there until $\overline{\text{DTR}}$ is set LOW. It then loops until either $\overline{\text{CARRIER DETECT}}$ (CD) = LOW or $\overline{\text{BACK CARRIER DETECT}}$ (BCD) = LOW occurs.

Full-Duplex

In full-duplex data reception, carrier may appear at any time after the phone connection has been established. Reception is independent of transmission. When the receiver detects a valid carrier for at least the time, t_{CDON} , the output CD goes LOW, and valid data can be obtained at RD. Data is received until the receiver detects loss of carrier for at least the time, t_{CDOFF} . At this time CD goes HIGH and RD is clamped to a Mark. The state machine returns to the idle loop at point E.

Half-Duplex

As discussed in the Data Transmission section, when a half-duplex mode has been selected, $\overline{\text{RTS}}$ controls whether the main channel is transmitting or receiving. The back channel can only do the opposite from the main channel. If $\overline{\text{RTS}}$ is HIGH, CD may be activated and the data reception sequence is identical to that discussed above for full-duplex reception. As long as $\overline{\text{RTS}}$ remains HIGH, BCD will never be activated. If $\overline{\text{RTS}}$ is LOW, then CD will never be activated. Instead, the receiver will look for a valid carrier in the back channel frequency band. If a valid carrier exists for at least the time, t_{BCDON} , BCD changes to LOW, and valid data can be obtained at BRD. Data is received until the receiver detects loss of back channel received signal for at least the time, t_{BCDOFF} . At this time, BCD goes HIGH. BRD is clamped to a Mark if V.23 mode or 202 150 bps back channel mode is selected. For 202 5 bps back channel mode, BCD represents the received data. BRD can be ignored. The state machine returns to the idle loop at point E.

LOOPBACK

Eleven modes exist to allow both analog and digital loopback for each modem specification met by the Am79101. When a loopback mode is selected, the signal processing (filters, etc.) for both the transmitter and receiver is set to process

* All timing delays are listed in Table 5.

PRELIMINARY AN79101 DATA SHEET

the same channel or frequency band. This allows the analog output, TC, and the analog input, RC, to be connected externally for local analog loopback. Alternately the digital data signals, TD and RD or BTD and BRD, can be connected externally, allowing a remote modem to test the local modem with its digital data signals looped back.

When a loopback mode is selected, the state machine sequences are altered slightly. If a half-duplex loopback mode is selected (202 or V.23), the local $\overline{\text{CD}}/\overline{\text{BCD}}$ is not forced HIGH when $\overline{\text{RTS}}/\overline{\text{BRTS}}$ is asserted.

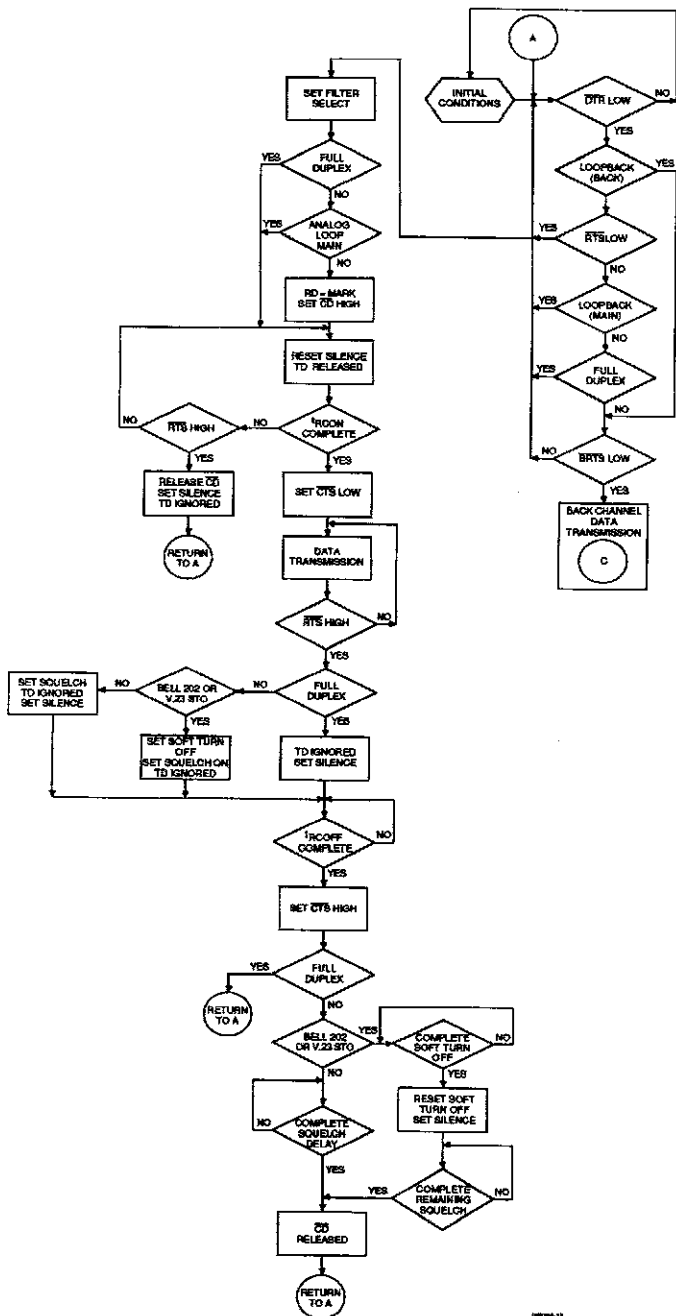

Figure 8a. Transmit Main Channel State Diagram

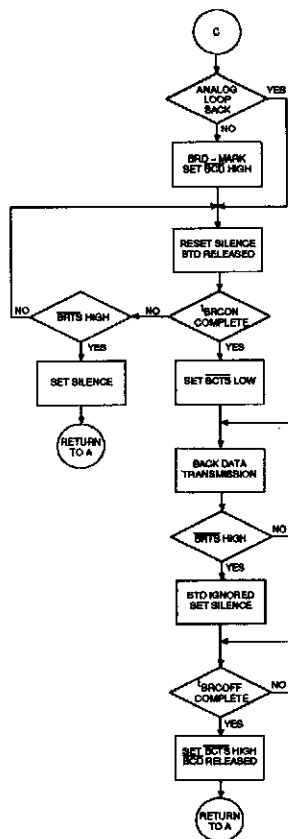

Figure 8b. Transmit Back Channel State Diagram

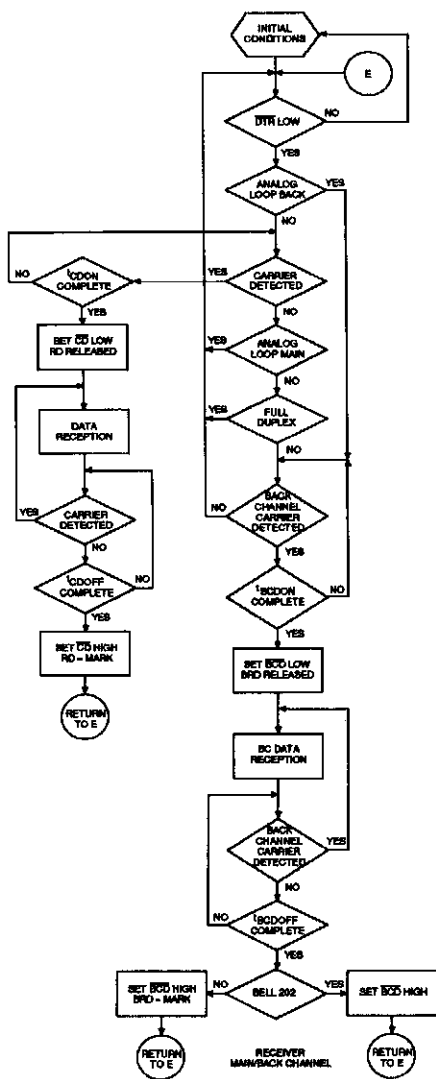

Figure 9. Receiver Main/Back Channel State Diagram

Table 5. Timing Parameters

(Refer to Figures 6b, 10, 11, 12, and 13 for Timing Diagrams)

Symbol	Description	Bell 103	CCITT V.21	Call Mode	Units
t _{RCON} (1)	Request-to-Send to Clear-to-Send ON Delay	208.3	400	-	ms ±0.3%
t _{RCOFF} (2)	Request-to-Send to Clear-to-Send OFF Delay	0.4	0.4	-	ms +40%
t _{CDON} (3)	Carrier Detect ON Delay	92-106	300-312	-	ms
t _{CDOFF} (4)	Carrier Detect OFF Delay	21-40	21-40	-	ms
t _{CDCON} (5)	Carrier Detect Call ON Delay	-	-	92-106	ms
t _{CDCOFF} (6)	Carrier Detect Call OFF Delay	-	-	21-40	ms

Table 5. Timing Parameters (Continued)
 (Refer to Figures 6b, 10, 11, 12, and 13 for Timing Diagrams)

Symbol	Description	CCITT V.23	Bell 202	Bell 202 150 bps Back and CCITT V.23 Back	Bell 202 5 bps Back	Units
t_{RCON} (1)	Request-to-Send to Clear-to- Send ON Delay	208.3	183.3	-	-	ms +0.3%
t_{RCOFF} (2)	Request-to-Send to Clear-to- Send OFF Delay	0.4	0.4	-	-	ms +40%
t_{BRCON} (7)	Back Channel Request-to-Send to Clear-to- Send ON Delay	-	-	82.3	-	ms +0.64%
t_{BRCOFF} (8)	Back Channel Request-to-Send OFF Delay	-	-	0.4	-	ms +40%
t_{CDON} (3)	Carrier Detect ON Delay	11.4- 15.4	18 - 22	-	-	ms
t_{CDOFF} (4)	Carrier Detect OFF Delay	5.4- 13.3	12.4- 23.4	-	-	ms
t_{BCDON} (9)	Back Channel Carrier Detect ON Delay	-	-	17 - 25	17 - 25	ms
t_{BCDOFF} (10)	Back Channel Carrier Detect OFF Delay	-	-	21 - 38	21 - 38	ms
t_{SQ} (11)	Receiver Squelch Duration	156.3	156.3	-	-	ms +3.3%
t_{STO} (12)	Transmitter Soft Turn-Off Duration	24*	24	-	-	ms +2.3%

* For V.23 Soft Turn-off modes only.

PRELIMINARY AM79101 DATA SHEET

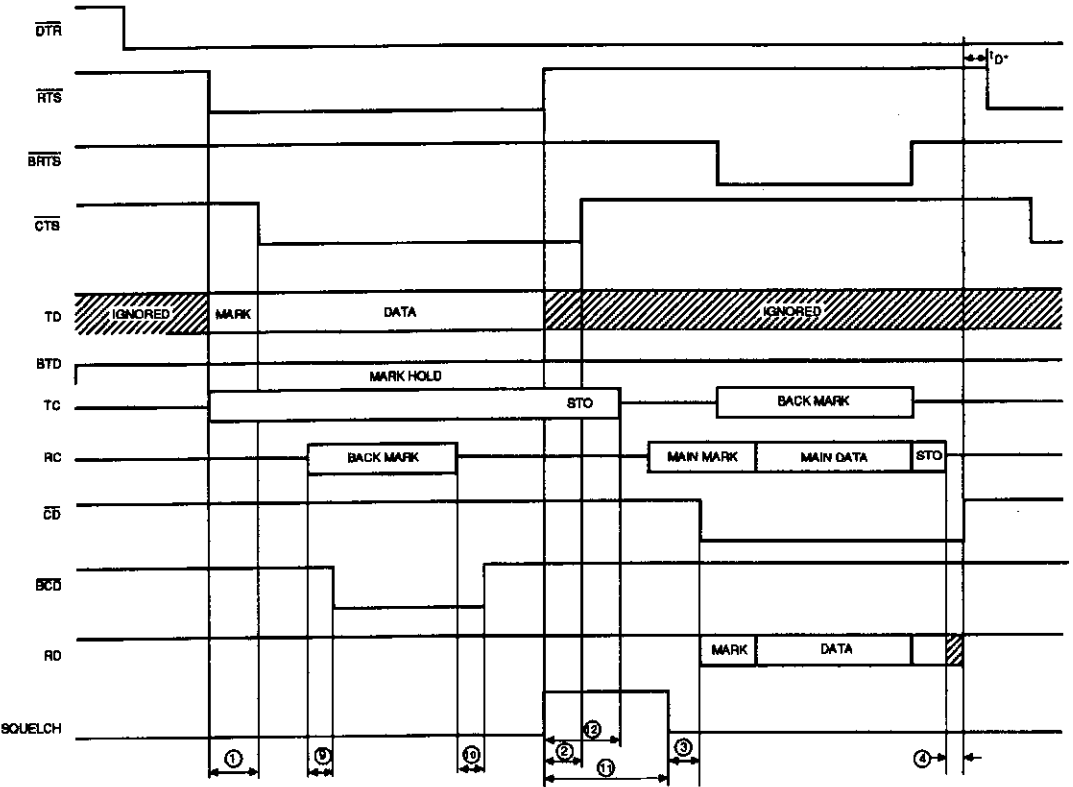

Figure 10. Bell 202 Handshake Timing with 5 bps Back Channel **

* t_D is an external delay provided by the user; $t_D > 0$.
 ** This timing diagram is not to scale. See Table 5 for values.

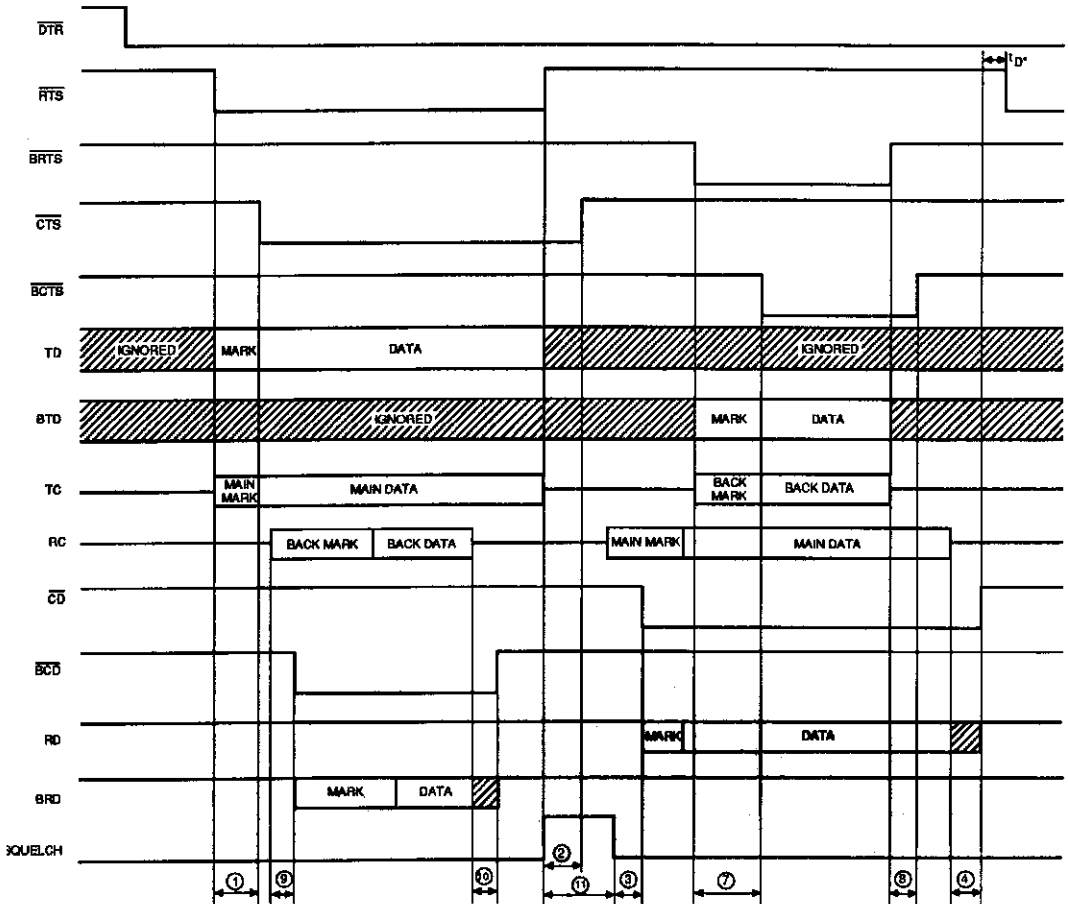

Figure 11. CCITT V.23 Handshake Timing **

* t_D is an external delay provided by the user; $t_D > 5$ ms.
 ** This timing diagram is not to scale. See Table 5 for values.

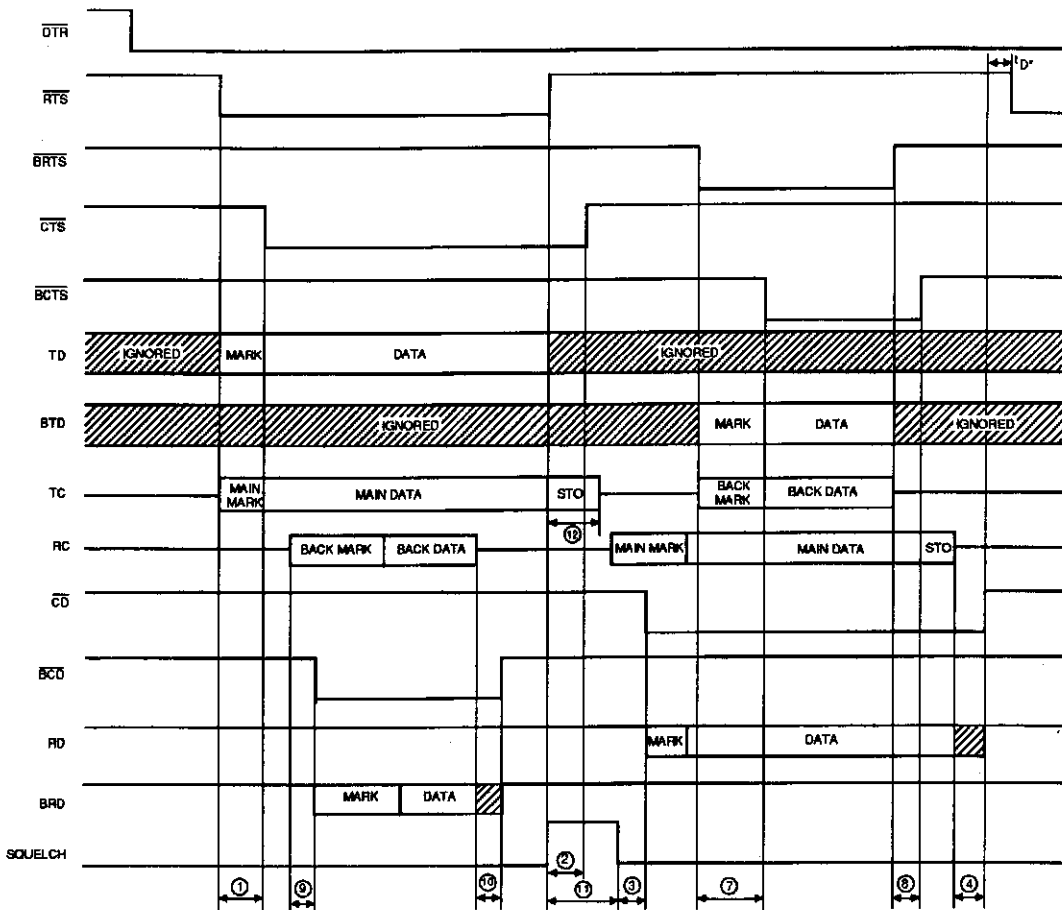

Figure 12. V.23 STO and Bell 202,
150 bps Handshake Timing**

* t_D is an external delay provided by the users; $t_D > 0$.
 ** This timing diagram is not to scale. See Table 5 for values.

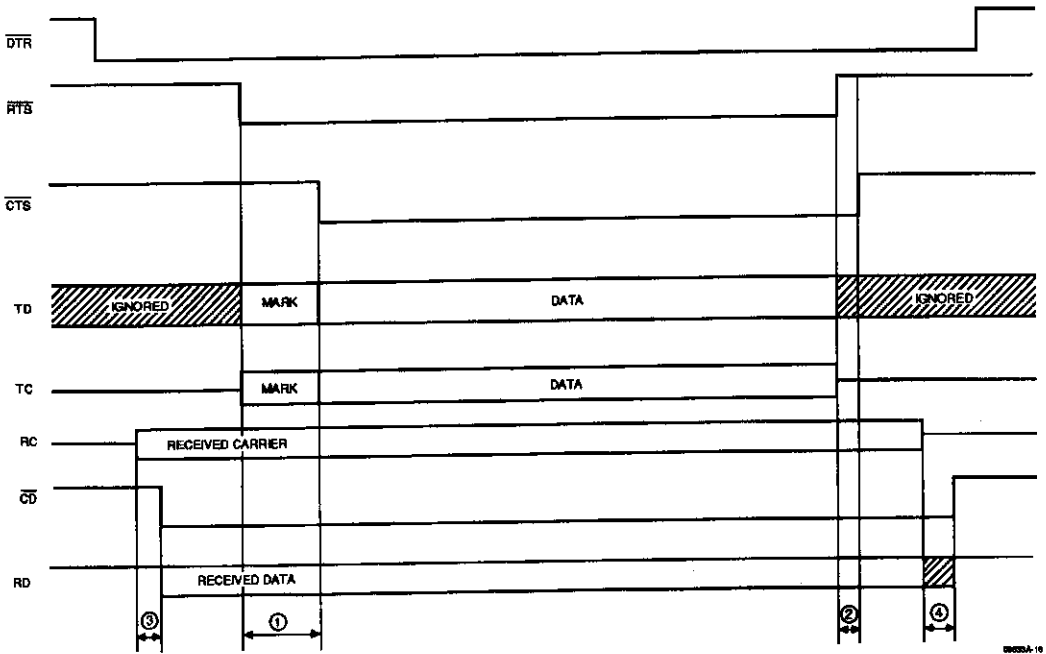

Figure 13. Bell 103/V.21 Handshake Timing*

* This timing diagram is not to scale. See Table 5 for values.

CLOCK GENERATION

Master timing of the modem is provided by either a crystal connected to the XTAL₁ and XTAL₂ pins or an external clock applied to XTAL₁.

Crystal

When a crystal is used it should be connected as shown in Figure 14a. The crystal should be a parallel resonance type, and its value must be 2.4576 MHz \pm .01%. A list of crystal suppliers is shown below.

External Clock

This clock signal could be derived from one of several crystal-driven baud rate generators. It should be connected to XTAL₁ and XTAL₂ must be left floating. The timing parameters required of this clock are shown in Figure 14b and the values are listed in Table 6.

Crystal Information (f=2.4576 MHz)

Manufacturer	P/N	C ₁	C ₂
M-Tron	MP-2	10 pF	20 pF
Monitor Products	MM-33	10 pF	20 pF

Note: Rise time of V_{CC} must be greater than 5 ms to insure proper crystal oscillator start-up.

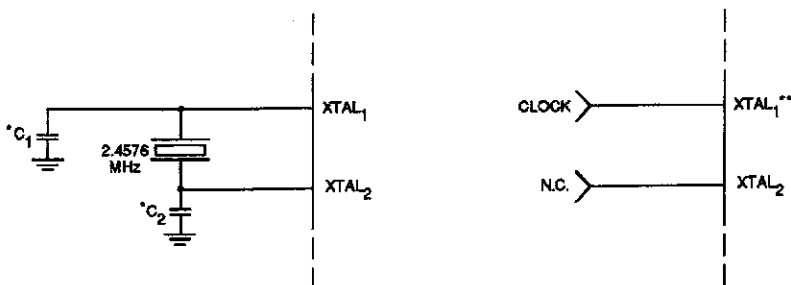

- * Capacitor values vary with different crystal manufacturers.
- ** The input impedance of this pin appears as 5 to 10 pF to ground in parallel with at least 1 Megohm.

Figure 14a. Clock Generation

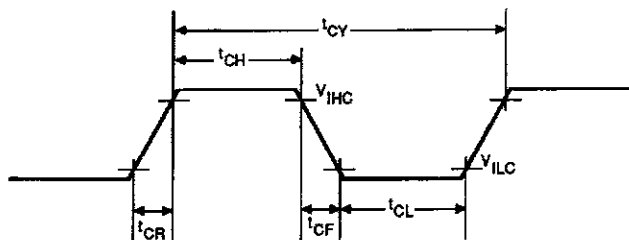

09833A-19

Figure 14b. External Clock

Table 6. Clock Parameters

Symbol	Parameters	Min	Typ	Max	Units
t_{CY}	Clock Period	406.86	406.9	406.94	ns
t_{CH}	Clock High Time	165			ns
t_{CL}	Clock Low Time	165			ns
t_{CR}	Clock Rise Time			20	ns
t_{CF}	Clock Fall Time			20	ns

RESET MODES

Automatic Power-On Reset--Figure 15a suggests a circuit to initiate the internal reset sequence automatically whenever V_{CC} is applied. V_{CC} rise time should be faster than one half the RC time constant. The Am79101 contains a diode to discharge the capacitor when $V_{CC} = 0$ V.

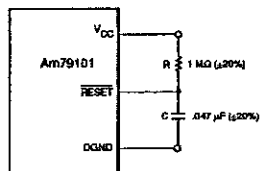

09833A-20

Figure 15a. Automatic Reset

RESET Input--The Am79101 can be forced into the internal reset sequence by setting $\overline{\text{RESET}}$ LOW for at least one clock period.

Note that V_{CC} must be at least +3.5 V for proper reset operation. Between repetitive reset pulses, $\overline{\text{RESET}}$ must be HIGH for at least 1 μs , as shown in Figure 15b.

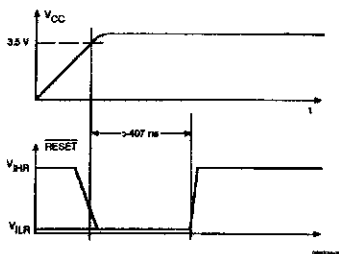

Figure 15b. Reset Timing Diagrams

Upon device initialization or mode change $\overline{\text{DTR}}$ must be brought HIGH for a time $t_{MSU} > 100$ microseconds, as shown in Figure 16.

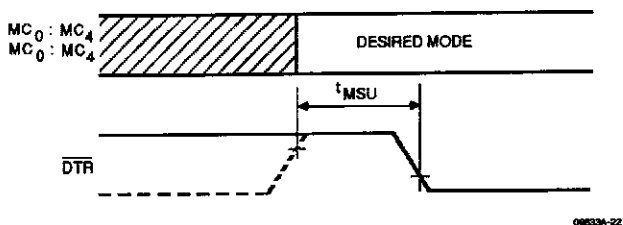
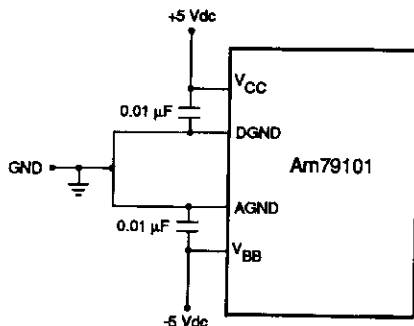

Figure 16. Mode Setup

POWER SUPPLY

For maximum performance, power supply bypassing should be used. V_{CC} should be decoupled to $DGND$ and V_{BB} to $AGND$ as shown in Figure 17. The 0.01 μF ceramic disc capacitors should be mounted as physically close to the pins as possible.



09823A-31

Figure 17. Power-Supply Connections

ABSOLUTE MAXIMUM RATINGS

Storage Temperature	-65 to +125°C
Ambient Temperature with Power Applied	
Commercial (C) Devices	0 to + 70°C
Industrial (I) Devices	-40 to + 85°C
Extended (E) Devices	-55 to +125°C
V _{CC} with Respect to DGND	+6 V / - .4 V
V _{BB} with Respect to DGND	-6 V / + .4 V
All Signal Voltages with Respect to DGND	+ 5 V

Stresses above those listed under ABSOLUTE MAXIMUM RATINGS may cause permanent device failure. Functionality at or above these limits is not implied. Exposure to absolutely maximum ratings for extended periods may affect device reliability.

Operating Ranges

Positive Supply Voltage (V _{CC})	+4.75 to + 5.25 V
Negative Supply Voltage (V _{BB})	-4.75 to - 5.25 V
Commercial (C) Devices	0 to + 70°C
Industrial (I) Devices	-40 to + 85°C
Extended (E) Devices	-55 to +125°C

Operating ranges define those limits over which the functionality of the device is guaranteed.

PRELIMINARY AM79101 DATA SHEET

DC CHARACTERISTICS (over operating ranges unless otherwise specified)

Digital Inputs: $\overline{DA/CA}$, $\overline{MC_0-MC_4}$, \overline{DTR} , \overline{RTS} , \overline{BRTS} , TD, BTD, \overline{RESET}

Digital Outputs: \overline{CTS} , \overline{BCTS} , \overline{CD} , \overline{BCD} , RD, BRD

Parameters	Description	Test Conditions	Min	Typ	Max	Units
V _{OH}	Output HIGH Voltage	I _{OH} = -400 μ A C _{LD} = 50 pF	2.4			V
V _{OL}	Output LOW Voltage	I _{OL} = 2 mA C _{LD} = 50 pF				
		C, I Devices			0.4	V
		E Devices			0.6	V
V _{IH}	Input HIGH Voltage		2.0		V _{CC}	V
V _{IL}	Input LOW Voltage		-0.5		0.8	V
V _{IHC}	External Clock Input HIGH (XTAL ₁)		3.8		V _{CC}	V
V _{IILC}	External Clock Input LOW (XTAL ₁)		-0.5		0.8	V
V _{IHR}	External Reset Input HIGH (RESET)		3.8		V _{CC}	V
V _{IILR}	External Reset Input LOW (RESET)		-0.5		0.8	V
I _{IL}	Digital Input Leakage Current	0.0 < V _{IN} < V _{CC}	-10		10	μ A
I _{IILR}	Reset Input Leakage Current	0.0 < V _{IN} < V _{CC}				μ A
		C, I Devices	-0.75		0.75	
		E Devices	-1.0		1.0	

DC CHARACTERISTICS (Continued)

Parameters	Description	Test Conditions	Min	Typ	Max	Units
I _{CC}	V _{CC} Supply Current	C Devices			140	mA
		I Devices			160	
		E Devices			170	
I _{BB}	V _{BB} Supply Current	C Devices			15	mA
		I Devices			20	
		E Devices			25	
C _{OUT}	Output Capacitance	f = 1.0 MHz		5	15	pF
C _{IN}	Input Capacitance	f = 1.0 MHz		5	15	pF

Power Supply	Description	Test Conditions	Min	Typ	Max	Units
V _{CC}	Positive Supply Voltage		4.75		5.25	V
V _{BB}	Negative Supply Voltage		-4.75		-5.25	V
AGND, DGND	Ground Offset		-50		50	mV

Standard Load Circuit

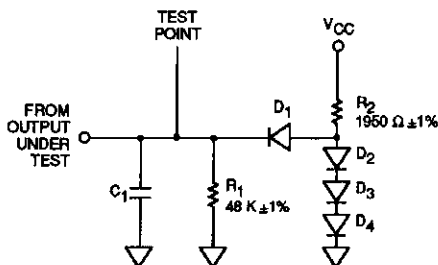

- Notes: 1. $C_1 = 50$ pF including stray and wiring capacitance
 2. All diodes are 1N3064 or equivalent
 3. All resistors are 1/8 watt
 4. $V_{CC} = 5$ Volts $\pm 5\%$

SWITCHING CHARACTERISTICS

DTMF and ATG Output	Description	Min	Typical	Max	Units
VLT	Output Voltage LOW group		0.652 -1.5		V _{RMS} dBm
VHT	Output Voltage HIGH Group		0.820 0.5		V _{RMS} dBm
VAT	Output Voltage Answer Tone		0.518 -3.5		V _{RMS} dBm

Modulated Transmit Output	Description	Min	Typical	Max	Units
VTC	TC Output Voltage		0.518 -3.5		V _{RMS} dBm
VTCOS	TC DC Offset	-100		100	mV
VHARM	Harmonics from Fundamental		-45		dB
TDEL	Delay from TD to TC Change			8.3	us
f _{ACC}	Frequency Accuracy (Except 202)	-0.4		0.4	Hz
f _{ACC}	Frequency Accuracy 202 Mark	-1.0		1.0	Hz
Out-of-Band energy: See Figure 19					

SWITCHING CHARACTERISTICS (Continued)

Receiver Input	Description	Min	Typical	Max	Units
VRC	RC Input Voltage	-1.6		1.6	V
RIN	Input Resistance	50			Kohms
FTOL	Frequency Deviation Tolerance	-16		16	Hz
VCDON	Carrier Detect On Level		-45		dBm
VCDOFF	Carrier Detect Off Level		-49		dBm
VCDCON	Carrier Detect Call On Level		-37		dBm
VCDCOFF	Carrier Detect Call Off Level		-41		dBm
VHYS	Carrier Detect Hysteresis		4		dB

Note: All TC Levels are measured using a 1200 ohm Load.
All dBm measurements are referenced to 600 ohm.

PERFORMANCE

Figure 18 shows a graph of nominal bit error rates for the various modem types. A flat line condition, back-to-back wire connection, is used to allow easy correlation by users.

PRELIMINARY AM79101 DATA SHEET

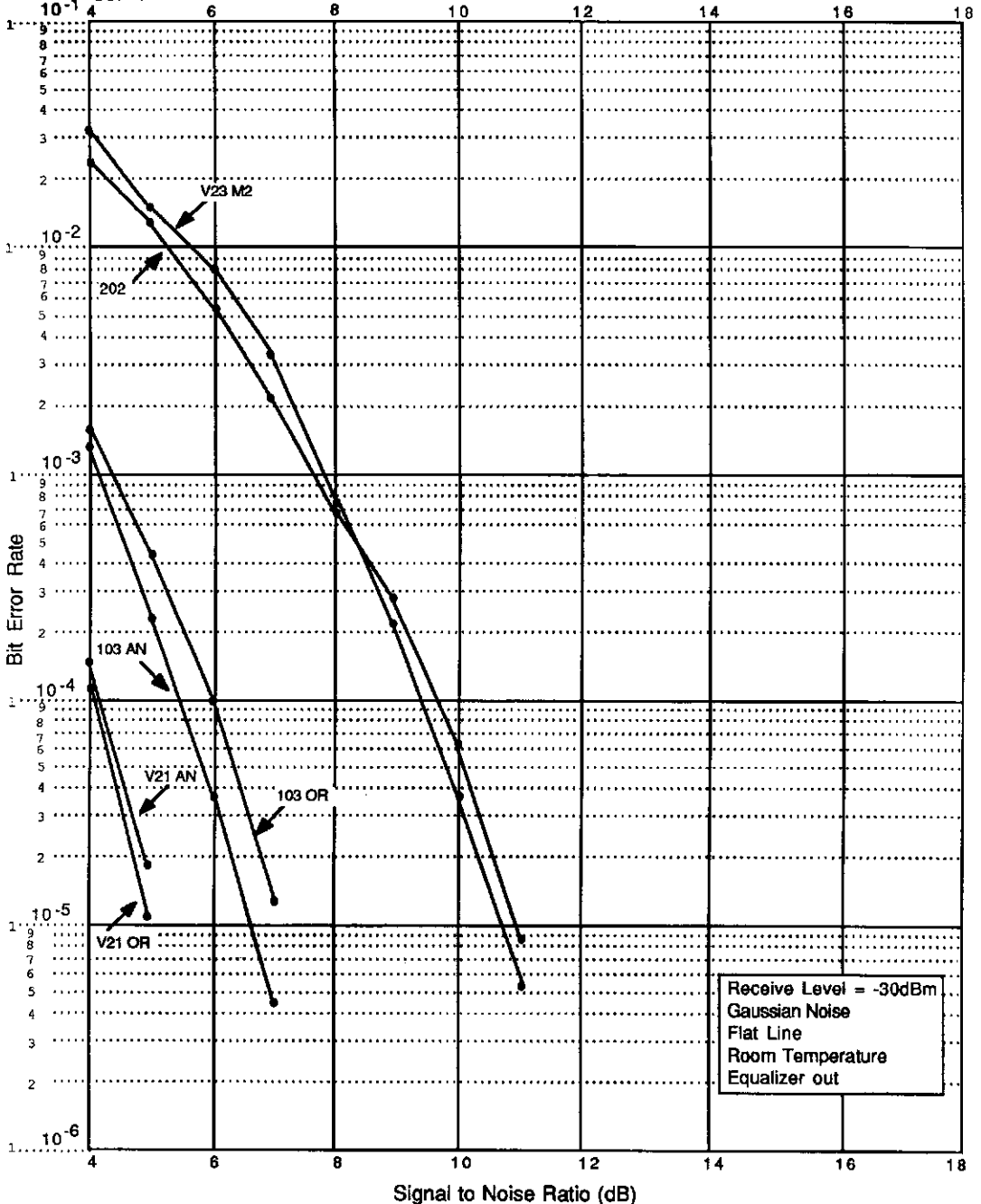
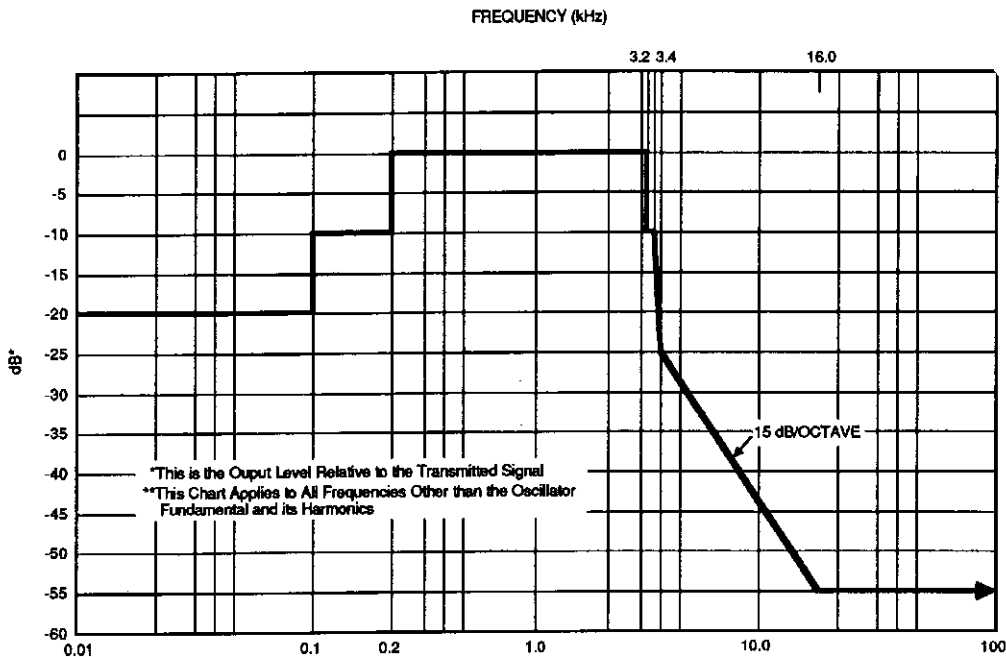

Figure 18. Am79101 Nominal Bit Error Rate



09632A-25

Figure 19. Out-of-Band Transmitter Energy**

APPLICATIONS

An intelligent Autodial, Autoanswer FSK modem can be easily built with the Am79101. Figures 20 and 21 show implementations of full-duplex and half-duplex modes.

For the full-duplex 103/V.21 modes, a single baud rate (300 bps) is used. With its on-chip UART, the single-chip microcontroller Am8051 provides a simple solution. The Am79101's RS-232C signals and setup controls are connected to the Am8051 as shown in Figure 20. MC₄ conveniently controls the on-hook relay in the DAA circuit. MC₄=0 activates off-hook and MC₄=1 keeps on-hook during analog loopback for local testing. If DTMF dialing is not permitted on a particular telephone network, the relay contact can be rapidly made and broken for pulse dialing.

Automatic answering of incoming calls is serviced like an interrupt routine by the Am8051. Upon ringing, the DAA interrupts the Am8051, which then places the relay off-hook and the Am79101 in the Call Mode to generate the answer tone. After the call is established or answered, the Am8051 has complete control to start data transfer.

For the half-duplex 202/V.23 modes, two different baud rates (1200 bps and 75/150 bps) are used for the main and back channels. A dual-UART system is required. Figure 21 shows an implementation with the Am8051 and the dual-channel Serial Communication Controller AmZ8530. The AmZ8530 can also be used in other CPUs, such as Z80, 8080, 6800 and 68000.

The internal hybrid of the Am79101 performs the 4-to-2 wire conversion to simplify the user interface to the switched telephone network. The analog signals TC and RC are coupled directly into the DAA circuit, as shown in Figure 22. For additional information, refer to AMD's 1987 Modem Technical Manual (PID# 09560A).

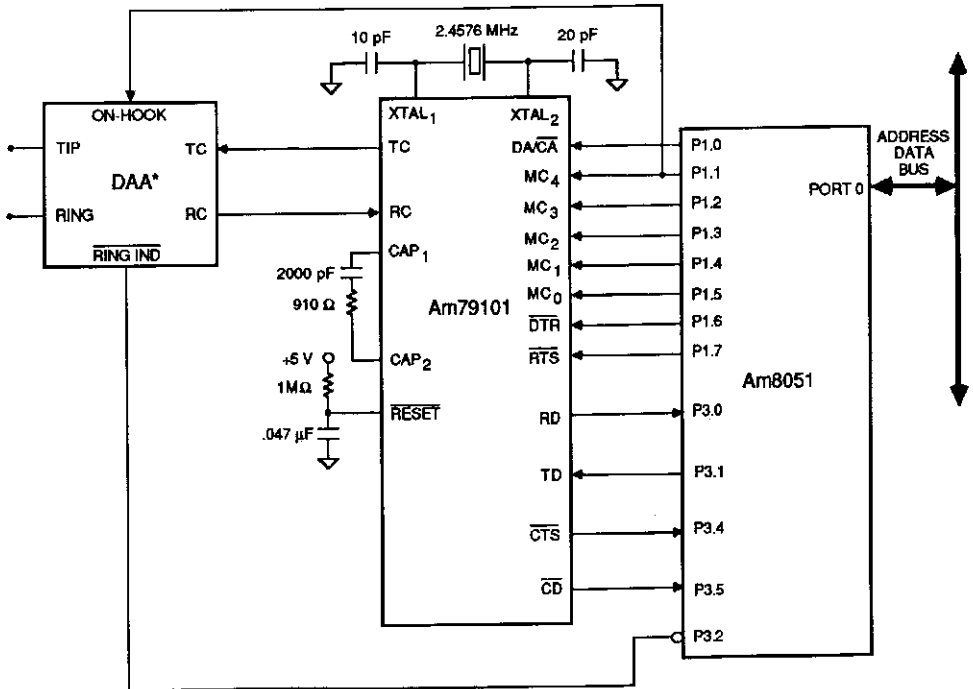

* See Figure 22.

Figure 20. 300 bps Full-Duplex Modem

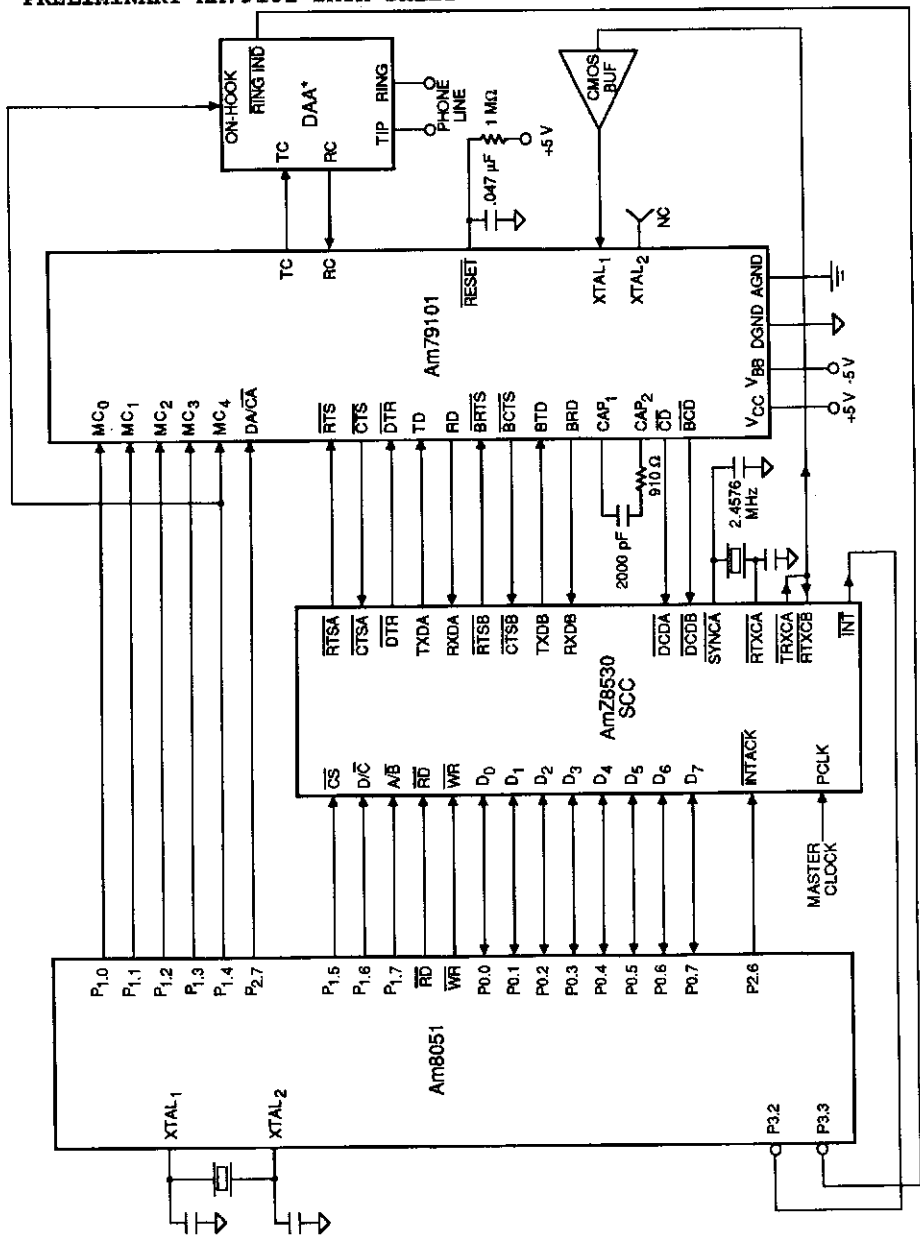

*See Figure 22.

Figure 21. 1200 bps Half-Duplex Modem with 75/150 bps Back Channel

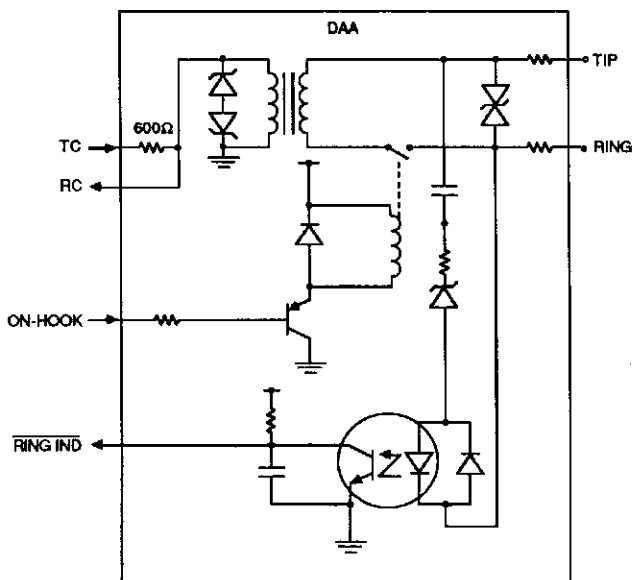
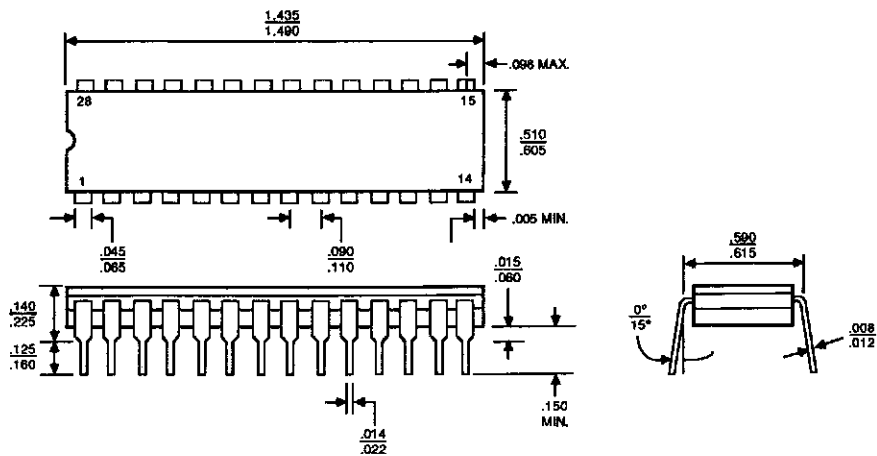

Figure 22. Data Access Arrangement

PHYSICAL DIMENSIONS



CD-028

PD-028

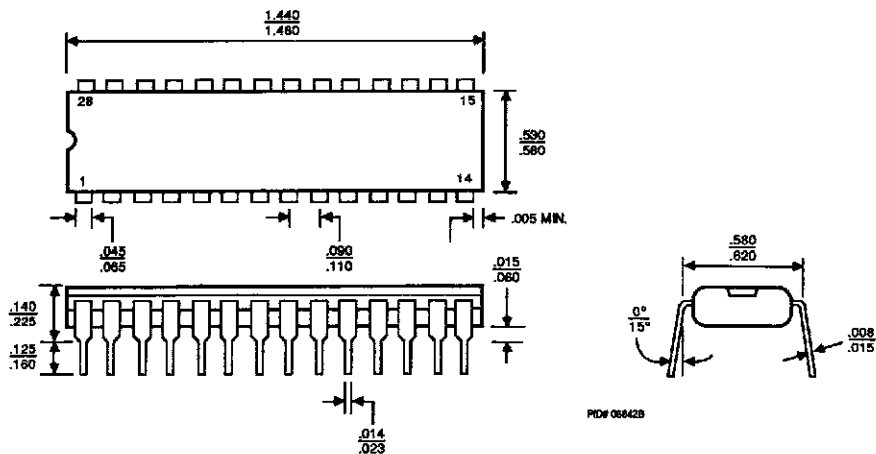

PL-028

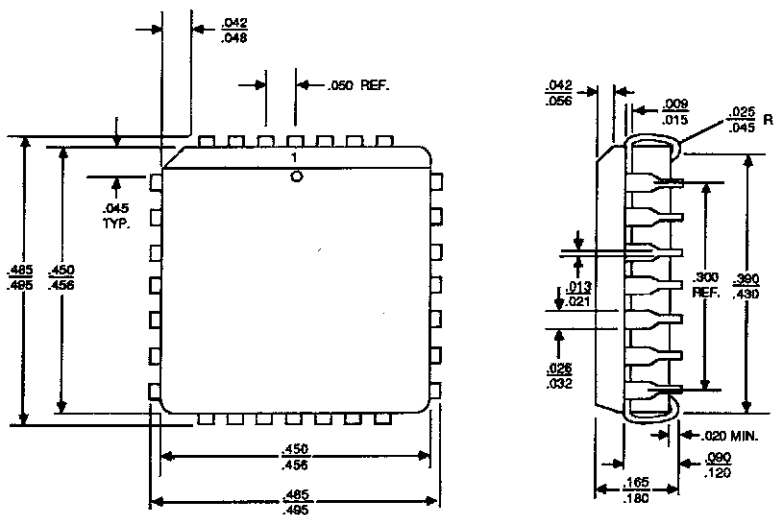

ADVANCED MICRO DEVICES' NORTH AMERICAN SALES OFFICES

ALABAMA	(205) 882-9122	KANSAS	(913) 451-3115
ARIZONA	(602) 242-4400	MARYLAND	(301) 796-9310
CALIFORNIA		MASSACHUSETTS	(617) 273-3970
Culver City	(213) 645-1524	MINNESOTA	(612) 938-0001
Newport Beach	(714) 752-8262	MISSOURI	(314) 275-4415
San Diego	(619) 560-7030	NEW JERSEY	(201) 299-0002
San Jose	(408) 249-7766	NEW YORK	
Santa Clara	(408) 727-3270	Liverpool	(315) 457-5400
Woodland Hills	(818) 992-4155	Poughkeepsie	(914) 471-8180
CANADA, Ontario		Woodbury	(516) 364-8020
Kanata	(613) 592-0060	NORTH CAROLINA	(919) 847-8471
Willowdale	(416) 224-5193	OHIO	(614) 891-6455
COLORADO	(303) 741-2900	Columbus	(614) 891-6455
CONNECTICUT	(203) 264-7800	Dayton	(513) 439-0470
FLORIDA		OREGON	(503) 245-0090
Clearwater	(813) 530-9971	PENNSYLVANIA	
Ft Lauderdale	(305) 776-2001	Allentown	(215) 398-8006
Melbourne	(305) 729-0496	Willow Grove	(215) 657-3101
Orlando	(305) 859-0831	TEXAS	
GEORGIA	(404) 449-7920	Austin	(512) 346-7830
ILLINOIS		Dallas	(214) 934-9099
Chicago	(312) 773-4422	Houston	(713) 785-9001
Naperville	(312) 505-9517	WASHINGTON	(206) 455-3600
INDIANA	(317) 244-7207	WISCONSIN	(414) 792-0590

ADVANCED MICRO DEVICES' INTERNATIONAL SALES OFFICES

BELGIUM		KOREA, Seoul	TEL	82-2-784-7598
Bruxelles	TEL		FAX	82-2-784-8014
	FAX			
	TLX			
FRANCE		LATIN AMERICA		
Paris	TEL	Ft. Lauderdale	TEL	(305) 484-8600
	FAX		FAX	(305) 485-9736
	TLX		TLX	5109554261 AMDFTL
GERMANY		NORWAY		
Hannover area	TEL	Hovik	TEL	(02) 537810
	FAX		FAX	(02) 591959
	TLX		TLX	79079
München	TEL	SINGAPORE		
	FAX		TEL	65-2257544
	TLX		FAX	2246113
Stuttgart	TEL		TLX	RS55650 MMI RS
	FAX	SWEDEN, Stockholm	TEL	(08) 733 03 50
	TLX		FAX	(08) 733 22 85
HONG KONG			TLX	11602
Kowloon	TEL	TAIWAN	TLX	886-2-7122066
	FAX		FAX	886-2-7122017
	TLX	UNITED KINGDOM		
ITALY, Milano	TEL	Farnborough	TEL	(0252) 517431
	FAX		FAX	(0252) 521041
	TLX		TLX	858051
JAPAN		Manchester area	TEL	(0925) 828008
Tokyo	TEL		FAX	(0925) 827693
	FAX	London area	TLX	628524
	TLX		TEL	(04862) 22121
Osaka	TEL		FAX	(04862) 22179
	FAX		TLX	859103

NORTH AMERICAN REPRESENTATIVES

CALIFORNIA		MICHIGAN		
I ² INC	OEM (408) 988-3400	SAI MARKETING CORP	(313) 750-1922	
	DISTI (408) 498-6868	MISSOURI		
CANADA		LORENZ SALES	(314) 997-4558	
Calgary, Alberta		NEBRASKA		
VITEL ELECTRONICS	(403) 278-5833	LORENZ SALES	(402) 475-4660	
Kanata, Ontario		NEW MEXICO		
VITEL ELECTRONICS	(613) 592-0090	THORSON DESERT STATES	(505) 293-8555	
Mississauga, Ontario		NEW YORK		
VITAL ELECTRONICS	(416) 676-9720	NYCOM, INC	(315) 437-8343	
Quebec		OHIO		
VITEL ELECTRONICS	(514) 636-5951	Columbus		
IDAHO		DOLFUSS ROOT & CO	(614) 885-4844	
INTERMOUNTAIN TECH MKGT	(208) 888-6071	Dayton		
INDIANA		DOLFUSS ROOT & CO	(513) 433-6776	
SAI MARKETING CORP	(317) 253-1668	Strongsville		
IOWA		DOLFUSS ROOT & CO	(216) 238-0300	
LORENZ SALES	(319) 377-4666	PENNSYLVANIA		
KANSAS		DOLFUSS ROOT & CO	(412) 221-4420	
LORENZ SALES	(913) 384-6556	UTAH		
		R ² MARKETING	(801) 595-0631	

Advanced Micro Devices reserves the right to make changes in its product without notice in order to improve design or performance characteristics. The performance characteristics listed in this document are guaranteed by specific tests, guard banding, design and other practices common to the industry. For specific testing details, contact your local AMD sales representative. The company assumes no responsibility for the use of any circuits described herein.