

CH1786 Family of Ultra Small 2400bps Modems

INTRODUCTION

The CH1786 family of modems are a full function, FCC Part 68 approved 2400bps modem. These modems provide a fast, easy and flexible way to integrate a modem into any OEM product while utilizing the minimum amount of PCB space (1.01 "x 1.27 "x 0.52 "). The CH1786 family only requires two external interfaces: a CCITT V.24 serial interface that can be routed directly to a UART, and a Tip and Ring interface which goes directly to an RJ-11 jack for the PSTN line connection. The CH1786 can be controlled with industry standard AT commands and, hence, is compatible with available industry communication software.

All CH1786 modems support asynchronous operation at 2400bps, 1200bps, and 300bps to both Bell and CCITT standards. The resident PSTN line interface, or Data Access Arrangement (DAA), while being FCC approved, is also Canadian DOT approvable and can be approved in other countries that require 1500VAC RMS isolation requirements per UL 1950 Edition 3.

The CH1786 family of modems operate off a single 5-volt supply. The low power operation and automatic standby mode make these modems ideally suited for portable equipment. In addition, their small physical size affords maximum flexibility in equipment design.

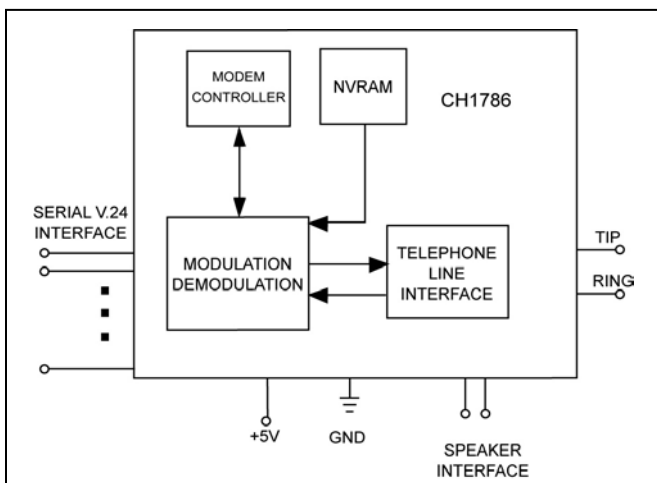

Figure 1. Functional Block Diagram of CH1786.

The CH1786 comes with FCC Part 68 approval and is shipped from the factory with an FCC Part 68 label indicating the registration number and ringer equivalent. This label should be prominently displayed on the end product.

FEATURES

- Supports Standards CCITT V.22bis, V.22, Bell 212, and Bell 103
- FCC Part 68 approved and DOT CSA CS-03 Part I approvable
- UL 1950 and CSA C22.2 950 Listed
- UL File Number: E104957
- AT Command structure with extensions
- 1500 VAC RMS isolation barrier minimum, 2122V peak surge protection minimum
- Single 5 volt operation
- Low power operation with automatic reduced power standby mode
- Automatic adaptive and fixed compromise equalization
- Size: 1.01 "x 1.27 "x 0.52 "(nominal)
- NVRAM allows storage of custom configurations and telephone numbers

CH1786 FAMILY

CH1786 NVRAM, Voice/ Inject, Hermetic, Operating Temperature: 0°C to +70°C

CH1786ET NVRAM, Voice/ Inject, Hermetic, Operating Temperature: -40°C to +85°C

CH1786NH Non-Hermetic, Operating Temperature: 0°C to +70°C

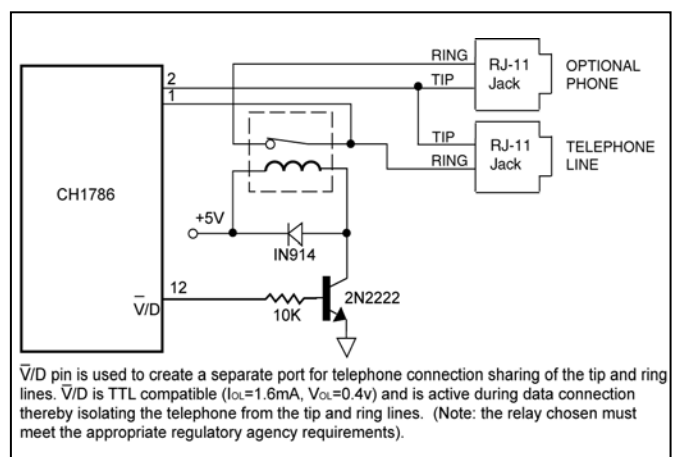

Figure 2. Voice/ Data Port Control

DESCRIPTION OF FUNCTIONAL BLOCKS AND DISCUSSION OF BASIC OPERATIONS

Figure 1 contains a functional block drawing of the CH1786. The CH1786 is a highly integrated, full-function modem, comprised of a modulator/demodulator, controller, NVRAM and an FCC Part 68 approved and UL 1950/CSA C22.2 950 listed PSTN line interface.

Modulation/Demodulation and Modem Controller.

These functions are provided by a monolithic modem integrated circuit. This IC has built-in facilities to accommodate integrated AT command control and contains the necessary resident interfaces for general communication and routing to the DAA.

Telephone Line Interface or DAA. The CH1786 family of modems is designed to meet 1500VAC RMS isolation and provide 2122V peak surge protection. Consequently, the CH1786 satisfies U.S. FCC Part 68 and DOT CSA CS-03 Part I Canadian requirements, and will meet other international approval agency requirements that specify these levels of isolation.

With the exception of the U.S., most countries (including Canada) require submission of the final product or system containing the CH1786 to the appropriate governing regulatory agency for approval. Typically this is accomplished by submitting the final end product to an independent test house or consultant for evaluation. The test house or consultant then forwards the test results and applicable documents to the regulatory agency. Call Cermetek for a list of suggested consultants.

Non-Volatile RAM (NVRAM). The NVRAM present on the CH1786 is sufficient to store up to two user customized modem configurations. The **AT&Wn** command will store the active modem configuration in the selected NVRAM locations by specifying an n of 0 or 1.

The **AT&Yn** command selects the modem configurations to be automatically recalled and made active upon a reset or power up. The **ATZn** command immediately recalls and activates a stored configuration. Refer to Tables 4, 5 and 6 for storable S-Registers and available commands.

The NVRAM can save up to four telephone numbers with up to 36 digits or modifiers in each telephone number. The **AT&Zn=s** command will store s, the telephone number dial string. The individual NVRAM telephone number storage locations are selected by specifying an n of 0,1,2,or 3. The **ATDTS=n** command will cause the modem to dial the stored telephone number in location n. NVRAM is not available on the CH1786LC or CH1786NH.

SUPPORT FEATURES

AT Command Set. A 40-character command line is supported. The command line starts with **AT** and may contain standard or enhanced commands. The commands are compatible with EIA Document TR302.2/88-08006.

Serial Host Interface. The serial interface is a V.24 (EIA-232) compatible interface. Ten Bits total: 1 start bit, 1 stop bit, and eight data bits which can be either eight bits with no parity or seven odd or even with parity. The start bit is LOW going. RXD and TXD data is non-inverted. See pin description in Table 2.

Speaker Interface. The SPK output reflects the receiver analog input and provides a signal that can be used to monitor call progress. The SPK signal can drive a 300 Ω load directly. Typically, the SPK signal is input into an audio power amplifier and the amplifier, in turn, drives the speaker coil. The speaker is activated with the **ATMn** command. The speaker volume is adjusted using the **ATLn** command, where n is 0,1,2,or 3. Increasing numbers correspond to higher volume. Figure 6 indicates one method of driving an external 8 Ω speaker.

Phone Control. Cermetek's CH1786 contains a pin called Voice or Data (\bar{V}/D). The \bar{V}/D pin toggles high when the modem goes off hook. This pin can be used to activate a relay which can switch a telephone on or off the Tip and Ring incoming PSTN lines. This feature allows any telephone associated with the CH1786 to be disconnected when a data call is in progress, thereby preventing the data from being disturbed by an inadvertent telephone pick-up. See Figure 2.

Speed and Parity Selection. Prior to call initiation, the host controller trains the modem to the host speed (2400,1200 or 300bps) and parity (odd, even, mark, space, or none) via a host-initiated training sequence. This training also sets the speed of the data for originate calls. The CH1786 will automatically adjust to the originator's speed when answering calls.

The CH1786 matches the host's parity when it returns status messages to the host. During a data connection, however, the modem passes parity through without interpretation or alteration.

Sleep Mode. To minimize power consumption, the CH1786 includes a power down feature called Sleep Mode. When activated, the CH1786 will automatically enter Sleep Mode after 0 to 254 seconds of inactivity. The inactivity delay is selected using the **ATS24** command. The CH1786 is delivered from the factory with a 5 second inactivity delay enabled (i.e., **ATS24=5**). The CH1786 returns to normal operation when a ring signal is received or

upon an input low signal on the TXD pin. **ATS24=255** disables the Sleep Mode and is the default if no value is set in register S24.

A SLEEP output signal is available to control power to external devices. In Figure 6, a FET controlled by the SLEEP signal turns of the external speaker amplifier when the CH1786 enters Sleep Mode. In Sleep Mode, power is reduced to approximately 50% of normal operating power.

Guard Tone. A guard tone of 550 Hz or 1800 Hz can be generated at 6 dB or 9 dB below the transmit level, respectively, by using the **&Gn** command. Refer to “Cermetek AT Commands and S-Registers reference Guide” or the Cermetek web site at <http://www.cermetek.com>.

Answer Tone. A CCITT (2100 Hz) or Bell (2225Hz) answer tone is generated depending on the selected configuration. Refer to “Cermetek AT commands and S-Registers Reference Guide” or the Cermetek web site at <http://www.cermetek.com>.

Data Encoding. The data encoding conforms to CCITT recommendations V.22bis or V.22, or Bell212A, or 103, depending on the selected configuration. Refer to “Cermetek AT commands and S-Register Reference Guide” or the Cermetek web site at <http://www.cermetek.com>.

Line Equalization. Transmitter and receiver digital filters compensate for delay and amplitude distortion during operation on nominal phone lines. In addition, automatic adaptive equalization in the receiver minimizes the effects of inter symbol interference.

Transmission Speed. In normal operation, the originating modem initiates the call and attempts to connect to the answering modem at a speed established by the originating modem’s controller prior to call initiation. This is referred to as the Initial Trained Rate. Upon receiving the call, the answering modem will attempt to connect to the originating modem at its Initial Trained Rate. If these two rates are identical, the connection is made. If the speeds differ, the answering modem must adjust its rate or terminate the call. Table 1 indicates the connection rate that will result when the calling modem’s Initial Trained Rate and the answering modem’s Initial Trained Rate are different.

NOTE

A 2400-baud connection rate will only result if both modems are initially set at 2400 baud.

Zero Power Mode (CH1786ET only). If an application calls for zero power during standby periods, the power may be switched off using external circuitry and then reapplied when the CH1786’s RI

pin becomes active. The CH1786ET products can thus be powered down to zero.

Table 1. Connection Rates.

Answering Modem Initial Trained Rate	Connection Rate Resulting When Calling Modem Initial Rate Is:		
	300	1200	2400
300	300	1200	1200
1200	300	1200	1200
2400	300	1200	2400

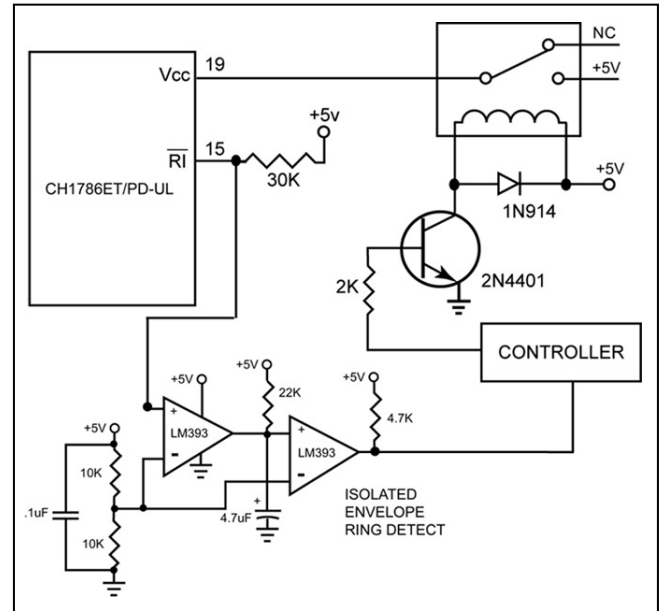

Figure 3. Zero Power Operation.

Referring to Figure 3, the controller activates the relay switch, supplying power (+5V) to the CH1786ET. In this configuration, the ring signal is used to “wake up” the CH1786ET when the CH1786ET is in the power down state.

The pins of the CH1786ET will be in an undefined state when power is switched off. This must be taken into consideration to assure that no unwanted signals are presented to the CH1786ET during power down.

Ring Indicator (RI). The RI pin follows the frequency of the ring signal and toggles low when the CH1786 detects an incoming call. The ring signal is typically 20 to 30 Hz and is on for 2 seconds and off for 4 seconds. Although not TTL compliant, the RI pin can, nonetheless, be utilized to activate external circuitry including the external RST pin.

When using the RI pin, it is recommended that a Schmitt Trigger or the Isolated Envelope Detect Circuit in Figures 3 or 5 be placed between the RI pin and the external load.

Power Supply. The CH1786 modem module is a complex set of sub-systems. During the course of

normal operation the CH1786 decodes analog signals from the telephone line that are in the millivolt range. Steps must be taken by the user to guarantee that power supply noise on all supply lines, including ground, does not exceed 50 mV peak to peak. Any frequency between 20 kHz and 150 kHz must be less than 500 micro volts peak. If necessary, use dedicated power and ground planes. Failure to provide such operating conditions could cause the CH1786 to malfunction or to function erratically.

The CH1786 requires a single +5V ±5% supply. It is recommended that by-pass capacitors be placed on the power supply as close to the modem's supply input as practical. It's recommended a 10 µF Tantalum capacitor in parallel with a 0.01 µF ceramic capacitor be used.

Voice/DTMF Tone Injection Port. The CH1786 provides two pins to allow the user to share the telephone line interface associated with the modem for voice and DTMF applications. Figure 4 contains a schematic indicating one possible configuration for voice/ tone utilization.

WARNING: The CH1786 has been FCC Part 68 approved as a data modem only. Utilization of the Voice/DTMF Tone Port requires further registration. FCC will require that the system, including the CH1786 and the handset or DTMF transceiver, adhere to Part 68 rules. Voice/Tone Injection is not active on CH1786NH.

Typically, voice communication would precede data communications. For this case, the following commands should be used to configure the CH1786 (Refer to Figure 4):

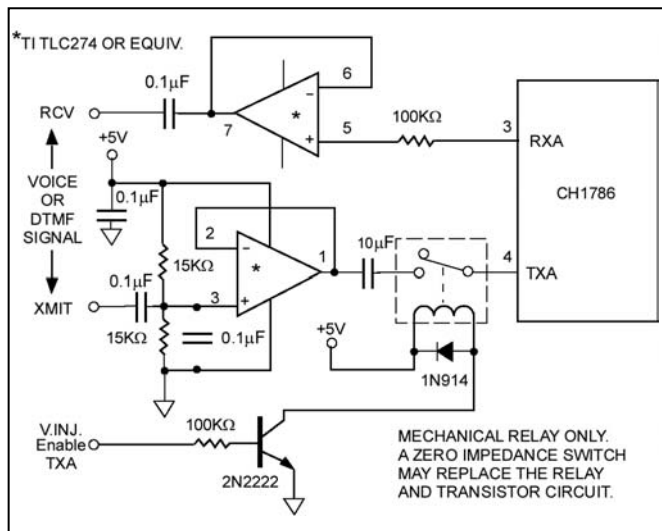

Figure 4. Voice/Tone Injection.

Enter: **ATS0=<CR>** Disables auto-answer
 Result: **OK**

Enter: **ATS7=255<CR>** Disables data-carrier time out
 Result: **OK**

Enter: **ATS10=255<CR>** Disables lost-carrier time out
 Result: **OK**

The following command sequences illustrate implementation of common Voice/Tone Port applications.

1. To answer a voice call.
 - (a) Enter: **ATH1<CR>**
Result: **OK**
 - (b) Drive V.INJ. HIGH to activate relay.
 - (c) Begin voice conversation.
2. To switch to data mode.
 - (a) Drive V.INJ. LOW
 - (b) At the originate modem:
Enter: **ATX1<CR>**
Result: **OK**
3. To disconnect (hang-up) a voice call or a data call.
 - (a) Enter: **ATH<CR>**
Result: **OK**
4. To place a call to 1234567 using the CH1786's DTMF tone generator.
 - (a) Enter: **ATDT1234567;C0<CR>**
Result: **OK**
 - (b) Drive V.INJ. HIGH

MODEM CONTROL

The CH1786 modem may be controlled by sending serial ASCII command sequences. The commands are sent to the modem serially on the TXD pin. After execution of a received command, the modem returns a serial status message that can be read on pin RXD. This message indicates command completion status. Refer to Table 3 for a complete list of status messages.

INITIALIZING THE MODEM

Before commands may be sent to the CH1786, the CH1786 must be initialized. Initialization is a two step activity consisting of:

1. Hard Reset. This is accomplished by applying a hardware reset pulse to pin RST or by switching the power off and then back on.
2. Initial modem training. The CH1786 must be trained to the host 's speed (2400,1200,300bps) and parity (odd, even, mark, space or none).

These activities are briefly described below.

Reset. Upon applying power to the CH1786, the CH1786 automatically generates an internal reset pulse. The user may also reset the modem externally by applying a high-going reset pulse to the RST pin for at least 10ms after the +5V power supply has stabilized. Delay sending commands to CH1786 for 200ms after reset has been initiated to allow the CH1786 time to properly reconfigure.

Training the Modem. Each modem must be trained to match its host's speed and parity so that it is able to recognize serial asynchronous commands sent to it by the host's UART. The host must retrain the modem each time a reset pulse is applied on RST or after a RESET serial command has been issued.

Modem Training Command Sequence. The CH1786 is trained by sending it the following sequence:

Enter: **AT<CR>**
Result: **OK**

Where: **A** and **T** may be either upper or lower case but must be the same case.

<CR> represents carriage return

The **AT** sequence is referred to as an attention sequence. The CH1786 will respond with one of the following status messages, depending on whether it is optioned for Terse (abbreviated) or Verbose (English) status messages.

Result: **0<CR>** (Terse)

or

Result: **<CR><LF>OK<CR><LF>** (Verbose)

Where: **<CR>** represents carriage return (ASCII 13 or HEX 0D).

<LF> represents line feed (ASCII 10 or HEX 0A).

After responding with an OK, the CH1786 is in idle mode and is ready to accept additional commands. An alternate attention sequence **A/** may be sent which behaves much like the **AT** sequence except that it causes the previously entered command specified with an **AT** prefix to be executed. When given, both the **AT** and **A/** must be in upper case ASCII. No carriage return is needed for the **A/** command.

THE COMMAND FORMAT

Typical commands consist of three elements: the attention sequence, the commands themselves, and a terminating carriage return.

AT[commands]<CR>.

Where: **AT** represents attention sequence.

[Commands] represents command strings.

<CR> represents carriage return (ASCII 13 or HEX 0D).

When entering commands to the modem, the backspace character-control-H (ASCII 8 or HEX 08) may be used to edit mistakes. **AT** and **A/** may not be edited. Multiple commands may be placed in the command line. A command line may be as long as 40 characters, excluding the letters **AT**. By way of example, the command below instructs the CH1786 to configure itself to not echo characters when in command mode **E0** and then put itself in answer mode **A**.

Enter: **ATE0A<CR>**

Result: **OK**

AT Command Set. The available command set is divided into four types of commands: dial modifiers, basic commands, ampersand and percent commands. Refer to the complete list in Table 5.

AT Command Data Rate. With the serial interface, the rate is speed sensed for parity and format.

THE STATUS MESSAGES

The CH1786 responds with a status message after each command is executed. This status message may either be a single digit followed by a carriage return or a carriage return and line feed with a message in English, followed by a carriage return and line feed.

The basic status code subsets are enabled with the Xn command. Where n=0,1,2,3,4 establishes the result codes allowed by the user.

X0: Result Codes 0, 1, 2, 3, 4 allowed
X1: Result Codes 0, 1, 2, 3, 4, 5, 10 allowed
X2: Result Codes 0,1, 2, 3, 4, 5, 6, 10 allowed
X3: Result Codes 0, 1, 2, 3, 4, 5, 7, 10 allowed
X4: Result Codes 0, 1, 2, 3, 4, 5, 6, 7, 10 allowed.

NOTE

The CH1786 is factory set to X4, which allows all result codes.

MODEM STATES

The CH1786 can be in either command mode or data mode. When the modem is idle, it is in command mode by default and will recognize commands. When data transmission is in progress, the CH1786 is in the data mode state and will not recognize commands. To force the CH1786 to recognize commands, the host must send an escape sequence to the CH1786 forcing it out of data mode and into command mode.

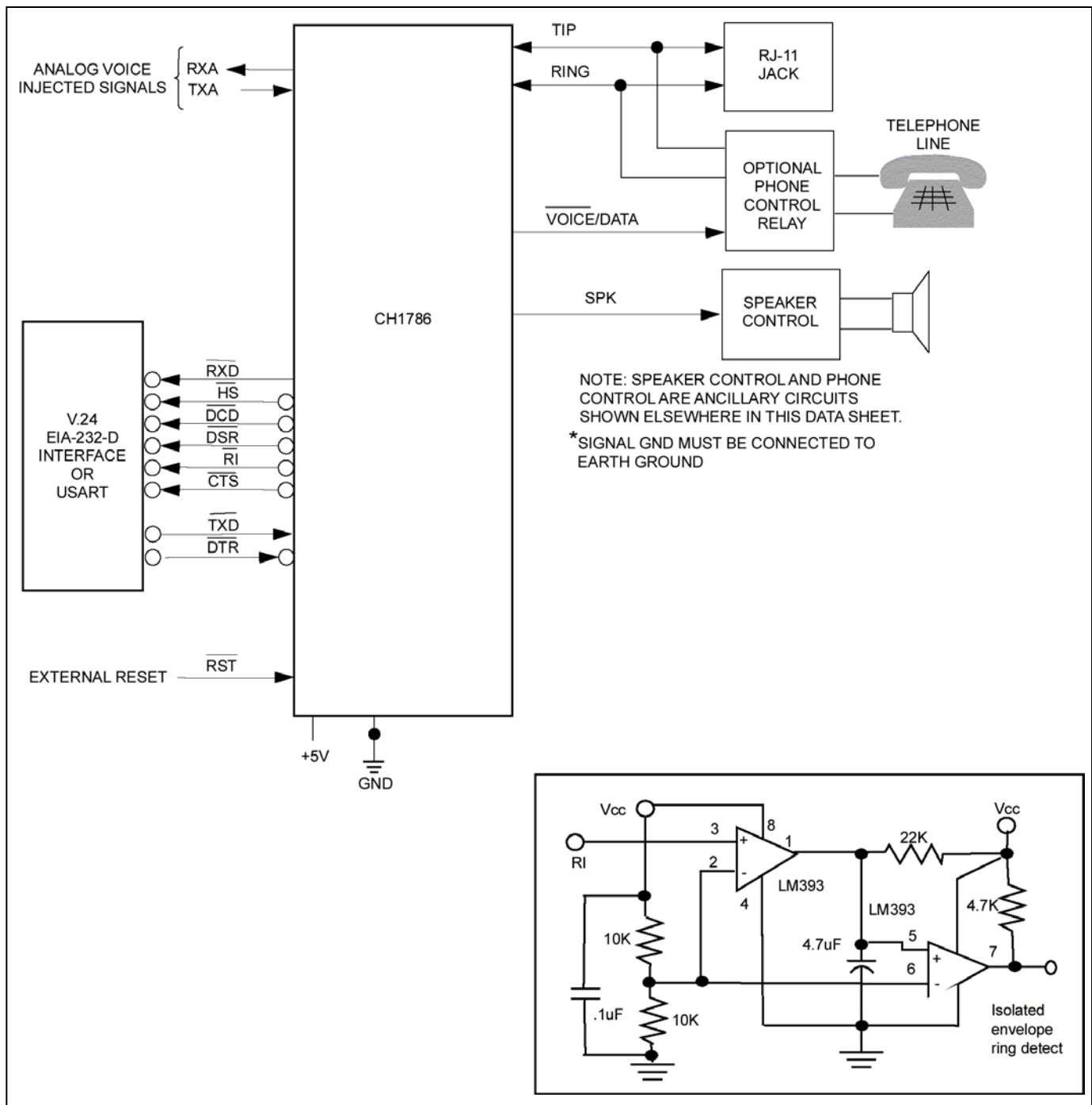

Figure 5. CH1786 Application Diagram

Table 2. CH1786 Pin Descriptions

PIN	NAME	TYPE	FUNCTION
1	RING	I/O	RING. Directly connects to the telephone line's Ring lead through a user supplied RJ-11C jack.
2	TIP	I/O	TIP. Directly connects to the telephone line's Tip lead through a user supplied RJ-11C jack.
3	RXA	O	ANALOG VOICE INJECTED. Receive Signal. Let float if not used. Not active in CH1786NH.
4	TXA	I	ANALOG VOICE INJECTED. Transmit Signal. Let float if not used. Not active in CH1786NH.
5	SPK	O	SPEAKER. Audio output for speaker. See speaker control schematic in Figure 6.
6	NC	-	No connection.
7	NC	-	No connection.
8	$\overline{\text{SLEEP}}$	O	SLEEP. A LOW indicates CH1786 is in low power idle mode. Used to control power to other devices. See Figure 6. Register S24 is the sleep timer register. When the CH1786 is inactive for a period of time specified by S24, the CH1786 will power down by about 50% of its normal operating power. During power down, all I/O lines become undefined. The CH1786 products are shipped from the factory with a 5 second inactivity timer (ATS24=5) enabled.
9	NC	-	No connection.
10	TXD	I	TRANSMIT DATA. Serial Transmit data input. Marking or a binary 1 condition is transmitted when a HIGH is asserted.
11	RXD	O	RECEIVE DATA. Serial Receive data output. Received marking or binary 1 condition is indicated by HIGH.
12	$\overline{\text{V/D}}$	O	VOICE/DATA. Used to switch between telephone and modem line use. In a typical application, $\overline{\text{V/D}}$ active HIGH opens the normally closed voice injection relay and disconnects the handset from the telephone line. HIGH indicates the CH1786 is off-hook and online. Therefore, this pin also reflects the state of the off-hook relay of the CH1786. See Figure 2.
13	$\overline{\text{DTR}}$	I	DATA TERMINAL READY. Active LOW. Switching off DTR can either return modem to command state, disconnect phone call, or reset modem. DET should be set LOW when not used.
14	$\overline{\text{DSR}}$	O	DATA SET READY. LOW indicates handshaking with a remote modem is in progress, and/ or the data carrier of a remote modem has been detected.
15	$\overline{\text{RI}}$	O	RING INDICATION. This signal follows the frequency of the ringing signal and is normally about 20 to 40 Hz for 2 seconds on with 4 seconds off.
16	$\overline{\text{CTS}}$	O	CLEAR-TO SEND. No connect if not using the FAX option. Reserved for flow control when using FAX option. CTS only active on CH1786 when S24=255.
17	$\overline{\text{DCD}}$	O	DATA CARRIER DETECT. LOW indicates a data carrier from a remote modem is detected. Must be enabled using the &C1 command.

Table 2. CH1786 Pin Descriptions Continuation

PIN	NAME	TYPE	FUNCTION
18	HS	O	SPEED INDICATION. HIGH speed select output. A low on this pin indicates the modem is operating at 2400bps.
19	VCC	-	POWER SUPPLY. 5 volts \pm 5% Note: Noise should be less than 50mV peak to peak.
20	GND	-	GROUND. Note: Noise should be less than 50mV peak to peak.
21	RST ¹	I	RESET. Active HIGH. This input must be asserted HIGH for at least 10 ms to reset the modem. RESET is then returned LOW for normal operation. If no system reset is available, let this pin float to enable internal reset.
22	NC	-	No connection required. For CH179X or CH2056 compatibility, connect to GND or use as an active LOW input for request to send (RTS) functionality for CH179X/2056 products.

Note: (1) If VCC has a slow power up ramp time, the internal reset may be ineffective.
 (2) Do not drive LED's directly from any output. Use Buffers.

Table 3. Summary of Result Codes and Meanings.

Result Codes	Status Message	Meaning
0	OK	Command Executed
1	CONNECT	Carrier detected at 300bps
2	RING	Ring Detected
3	NO CARRIER	Did not detect carrier
4	ERROR	Entry error
5	CONNECT 1200	Carrier detected at 1200bps
6	NO DIAL TONE	Off-hook, but no response after 5 seconds
7	BUSY	Busy signal detected
10	CONNECT 2400	Carrier detected at 2400bps

The escape sequence consists of a "guard time" (a period where no characters are sent to the modem), followed by 3 escape characters, followed by another guard time. The guard time is set by register S12. The escape character code is set in register S2. At power-up, the guard time is set to 1 second minimum, and the escape character is set as "+." There is no minimum delay between characters but the maximum delay is set by register S12.

The CH1786 will stay off-hook with its carrier on after the escape sequence is received. It will return an OK

status message when it is ready to accept commands. The CH1786 may be put into data mode by issuing the command **ATO<CR>**.

AT COMMAND APPLICATIONS

Dialing A Phone Number. The Dial command takes the form **Dn**, where n is a string of characters. In the simplest form, n will be only the digits of the phone number to be dialed.

Example: Dial number.
 Enter: **ATD1234567<CR>**

Result: **OK**

In response to this command, the CH1786 dials the telephone number "123-4567" and then waits for a carrier from the distant modem. If no carrier is detected within a given time (the default time is 30 seconds), the CH1786 automatically releases the line and sends a NO CARRIER result code. If a carrier is detected, the CH1786 gives a CONNECT result code and goes on-line, permitting communication with the distant modem.

The Dial Command may also be issued without a telephone number. ATD causes the modem to pick up the telephone line without dialing a number.

Pause During Dialing. When placing a call from an office with a telephone connected to a PBX, it may be necessary to dial an access code (usually the digit 9) to get an outside line. Inserting a comma in the telephone number instructs the modem to pause for a specific length of time. The factory set default pause time is 2 seconds.

Example: Dial 9,pause, dial number.
 Enter: **ATDT9,1234567<CR>**
 Result: **OK**

Multiple commas may be used to generate integer multiples of the specified delay time.

Originate a Call in Answer Mode. The D command forces the modem into originate mode. To call an originate-only modem, dial the number and set the modem to answer mode via the R command (reverse originate). This is done by including an R at the end of the telephone number.

Example: Change modem from original-only to answer mode.
 Enter: **ATDT1234567R<CR>**
 Result: **OK**

Multiple commas may be used to generate integer multiples of the specified delay time.

Redial Last Number. The repeat command is a convenient way to execute the previously entered command line.

Example: Use **A/**, the repeat command, to redial the last telephone number dialed.
 Enter: **A/**
 Result: **ATDT1234567R<CR>** Previous command line executed
OK

Return to Command State. Use ; to return to command mode offer dialing.
 Example: Touch-tone dial 9, pause, dial number, return to Command.

Enter: **ATDT9,1234567;<CR>**
 Result: **OK**

Automatic Answering. The SO register controls the number of rings that must occur before the modem answers a call. The register may range in value from 0 to 255.

- S0 = 0 DO NOT ANSWER TELEPHONE
- S0 = 1 ANSWER ON RING 1
- S0 = 2 ANSWER ON RING 2
- S0 = 3 ANSWER ON RING 3
- S0 = 255 ANSWER ON RING 255

When S0 is set to 0,the modem will not auto-answer.

The Serial Interface Lines. The CH1786 supports a full EIA-232D/V.24 serial interface. Signal levels are TTL rather than EIA-232D level compatible, which allows direct connection of the CH1786 to the host UART without the need for level translation circuitry. See Table 2 for a complete pin description.

The CH1786 is controlled by sending it serial commands over TXD and it's status determined by monitoring the serial status messages returned on RXD. DTR is optionally used to reset, terminate calls or return CH1786 to command mode.

All other serial interface lines may be utilized for the convenience of a particular application but are not required by the CH1786. Unused outputs (from modem) should be left unconnected. Unused inputs should be set to the proper logic level. See Table 2.

Fax Modes. The CH1786 Product Family supports Send and Receive FAX. The modes and rates are determined by the **AT+F** commands. Refer to Table 6A.

FAX modem processing is explicitly defined in CCITTV.29, CCITTV.27, and CCITT V.21 recommendations. All modulation, wave-form spectrum, and data processing functions conform to the appropriate specifications.

Table 4. CH1786 Register Summary.

Register	Function
S0*	Ring to Answer On
S1	Ring Count
S2	Escape Code Character
S3	Carriage Return Character
S4	Line Feed Character
S5	Back Space Character
S6	Wait for Dial tone
S7	Wait for Data Carrier
S8	Pause Time for Comma

Table 4. CH1786 Register Summary Continuation.

Register	Function
S9	Carrier Detect Response Time
S10	Lost Carrier to Hang-up Delay
S11	DTMF Dialing Speed
S12	Escape Code Guard Time
S14*	Bit Mapped Options Register
S16	Modem Test Options
S21*	Bit Mapped Options Register
S22*	Bit Mapped Options Register
S23*	Bit Mapped Options Register
S24	Sleep Mode Inactivity Time
S25*	Delay to DTR
S27*	Bit Mapped Options Register
S28*	Bit Mapped Options Register

Note

In Tables 4, 5, 6A-6C an * signifies parameters that are stored in NVRAM upon receipt of the &W command. The CH1786LC, CH1786LCNE, CH1786NE and CH1786NH do not contain NVRAM and, therefore, do not support data storage after power down. A detailed definition of all commands and registers is available from Cermetek Microelectronics, Inc. Refer to Cermetek Document AT Commands and S-Registers Reference Guide or access our website at www.cermetek.com.

Table 5. CH1786 AT Command Set Summary.

Basic Commands	Function
AT	Attention Code
A	Answer command
A/	Repeat last Command
BN*	Communications Standard Option
D	Dial Command
E*	Off-Line Character Echo Option
Hn	Switch Hook Control Option
Ln*	Speaker Volume Option
Mn*	Speaker Control Option
On	On-Line Command
P	Pulse Dial
Qn*	Result Code Display Option
Sn	Select an S Register
Sn=	Write to an S Register
Sn?	Read an S Register
Vn*	Result code Form Option
Xn*	Result Code Set/Call Progress Option
+++	Escape Code Sequence Pause
,	Pause
?	Returns Last addressed S Register
Yn*	Long Space Disconnect Option
Fn	On Line Echo character Option
Z	Reset

Table 6A. FAX Command Set Summary.

FAX Command	Function
+FCLASS=n	Select Service Class
+F<command>?	Report Active Configuration
+F<command>=?	Report Operating Capabilities
+FAA=n	Data/Fax Auto Answer
+FF	Enhanced Flow Control
+FTS=n	Stop Transmission and Wait
+FTSM=n	Transmit Data
+FTH=n	Receive Data
+FTH=n	Transmit Data with HDLC Framing
+FRH=n	Receive Data with HDLC Framing
+FRT=n	Receive Test Data
+FTTn=m	Transmit test Data

Table 6B. Dial Modifiers Summary.

Dial Modifiers	Function
P	Pulse Dial
R	Originate Call in Answer Mode
T	Touch Tone Dial
W	Wait for Dial Tone
;	Return to Idle State
@	Wait for Quiet Answer Command
!	Flash Hook
,	Paul
0-9	Dial Digits/Characters
A,B,C,D	

Table 6C. Ampersand and Percent Commands.

Ampersand Commands	Function
&Cn*	Data Carrier Detect Option
&Dn*	Data Terminal Ready Option
&F	Load Factory Defaults
&Gn*	Guard Tone Option
&Pn*	Make to Break Ratio Section
&Sn*	Data Set Ready Option
&Tn	Test Command Option
&V	View Active Configuration
&Wn*	Store Active Profile
&Yn*	Recall Active Profile
&Zn*	Store Telephone Numbers
Percent Commands	Function
%Dn	DTMF Attenuation
%J	Load Secondary Factory Defaults

PHONE LINE CONNECTION GUIDELINES

1. The CH1786 must be mounted in the final assembly such that it is isolated from exposure to any hazardous voltages within the assembly. Adequate separation and restraint of cables and cords must be provided.

2. The circuitry from the CH1786 to the telephone line interface must be provided in wiring that carries no other circuitry other than that specifically allowed in the FCC rules (such as A and A1 leads).
3. Connection to phone line should be made through an RJ-11C jack.
4. PCB traces from the modem's RING and TIP pins to the RJ-11C jack must be 0.1 inch spacing or greater to one another and 0.2 inch spacing or greater to all other traces. The traces should have a nominal width of 0.020 inches or greater.
5. The RING and TIP PCB traces should be as short as possible and oriented to prevent coupling other high speed or high frequency signals present on the host circuit PCB.
6. No additional circuitry other than that shown in Figure 7A or 7B may be connected between the modem module and the RJ-11C jack. Doing so will invalidate the FCC approval.
7. The CH1786LC, CH1786LCNE, and CH1786NH (only) requires external surge protection (see Figure 7B). This is mandatory to maintain FCC Part 68 conveyed approval.
8. The CH1786, the RJ-11C jack, the interfacing circuitry and all PCB traces in between, must be contained on a PCB with a 94 V-0 flammability rating.
9. The supplied FCC registration label must be applied visibly on the outside of the product.
10. The product's User Manual must provide the user with instructions for connection and use as recommended in the FCC Registration Section below.

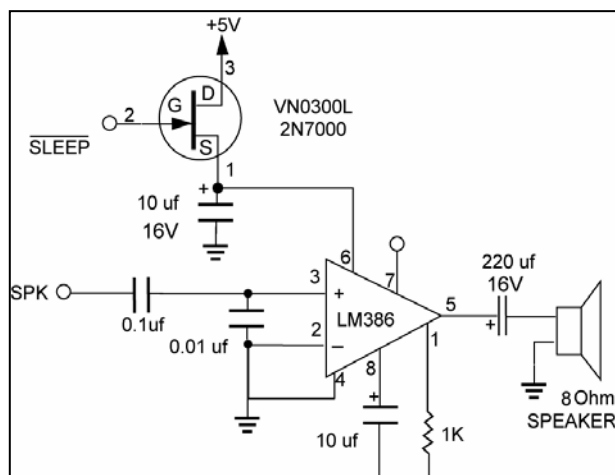

Figure 6. Speaker Control Circuit: Optional to allow for call progress monitoring.

CH1786 HANDLING AND ASSEMBLY RECOMMENDATIONS

The CH1786 contains static-sensitive components and should only be handled by personnel and in areas that are properly protected against static discharge. The two recommended mounting techniques for physically connecting the CH1786 to a PCB are discussed below.

Direct Soldering. The CH1786 may be wave soldered. All CH1786 products are hermetically sealed (except the CH1786LCNE, CH1786NE, and CH1786NH) and will not be harmed by industry standard wave soldering processes. Cermetek recommends against exposing the non-hermetic CH1786LCNE, CH1786NE, and CH1786NH to aqueous based rinsing processes.

Socketing. The socketing approach to mounting eliminates cleaning and desoldering concerns. When the socket is used, it must make a solid connection to all pins. Failure to do so will cause unreliable or intermittent operation. Also, steps should be taken to assure that the module remains tightly seated in the socket during shipping. Cermetek recommends using sockets from Samtec. See Application Note # 130, Summary of Recommended Suppliers.

FCC REGISTRATION

All products in the CH1786 family are registered with the FCC (Federal Communications Commission) under Part 68. To maintain the validity of the registration, you must serve notice to the end user of the products of several restrictions the FCC places on the modem and its use.

In addition to restriction notification, the FCC requires that Cermetek make all repairs to all products in the CH1786 family. If repairs are necessary after installation of the CH1786 in the end product and the end product has been delivered to the end user, the end product must be returned to the end product supplier where the CH1786 can be removed and then forward to Cermetek for repair. The following notice is recommended and should be included in the end product's user manual.

FOR YOUR USER'S MANUAL

The FCC Part 68 rules require the following (or equivalent) be provided to the end user of equipment containing a DAA.

Type of Service. The (insert end product name) is designed to be used on standard device telephone lines. It connects to the telephone line by means of a standard jack called the USOC RJ-11C (or USOC RJ45S). Connection to telephone-company-provided coin service (central office implemented systems) is

prohibited. Connection to party lines service is subject to state tariffs.

Changes in Attestation Procedure for Plugs and Jacks. (Name of applicant) attests that the network interface plugs or jacks used on this equipment comply with and will continue to comply with the mechanical requirements specified in Part 58, subpart F, specifically the dimensions, tolerances and metallic plating requirements. The compliance of these connectors will be assured by purchase specifications and incoming inspection. Documentation of such specifications and/or inspections will be provided to the FCC within 30 days of their request for the same.

Telephone Company Procedures. The goal of the telephone company is to provide you with the best service it can. In order to do this, it may occasionally be necessary for them to make changes in their equipment, operations or procedures. If these changes might affect your service or the operation of your equipment, the telephone company will give you notice, in writing, to allow you to make any changes necessary to maintain uninterrupted service.

In certain circumstances, it may be necessary for the telephone company to request information from you concerning the equipment which you have connected to your telephone line. Upon request of the telephone company, provide the FCC registration number and the ringer equivalence number (REN); both of these items are listed on the equipment label. The sum of all of the REN's on your telephone lines should be less than five in order to assure proper service from the telephone company. In some cases, a sum of five may not be useable on given line. Consult your telephone provider.

If Problems Arise. If any of your telephone equipment is not operating properly, you should immediately remove it from your telephone line, as it may cause harm to the telephone network. If the telephone company notes a problem, they may temporarily discontinue service. When practical, they will notify you in advance of this disconnection. If advance notice is not feasible, you will be notified as soon as possible.

When you are notified, you will be given the opportunity to correct the problem and informed of your right to file a complaint with the FCC. Contact your local telephone service provider if you have any questions about your phone line.

In the event repairs are ever needed on the (insert your product name), they should be performed by (insert your company name) or an authorized representative of (insert your company name). For information contact: (insert your company address).

DEFAULT STATUS, PERFORMANCE, AND SPECIFICATIONS

The following is a summary of the Default Configuration Profile installed by Cermetek Microelectronics, Incorporated, prior to delivery of the CH1786.

Async mode selected
 2400bps
 Bell 212A operation at 1200bps
 Even parity
 Auto answer enabled (Disabled on CH1786NH)
 Command echo ON
 All result codes enabled –extended
 Wait for dial tone before dialing =2 seconds
 Detects busy signal
 Full word result codes
 Pulse dial make/break ratio =39/61
 DSR enabled
 Modem enabled DTR (Disabled on CH1786NH)
 DCD enabled (Disabled on CH1786NH)
 Speaker enabled but off when receiving carrier
 Speaker volume set to medium
 Local modem will grant RDL request from remote modem
 Guard tones disabled
 Minimum DTR pulse width =0.1 seconds
 Ring count =01 (CH1786)
 Escape code character =43
 Carriage return character =13
 Line feed character =10
 Back space character =08
 Duration of wait for dial tone =02 seconds
 Duration of wait for carrier after dialing =30 seconds
 Duration of dial pulse (comma)=02 seconds
 Carrier detect response time =0.1 seconds
 Escape code guard time =1 second
 Length of use after comma =2.0 seconds
 Last carrier to hang up delay =0.1 seconds
 DTMF interdigit delay =0.1 seconds
 DTMF Attenuation =-4dB
 Sleep mode inactivity time =5 seconds
 Long space disconnect disabled

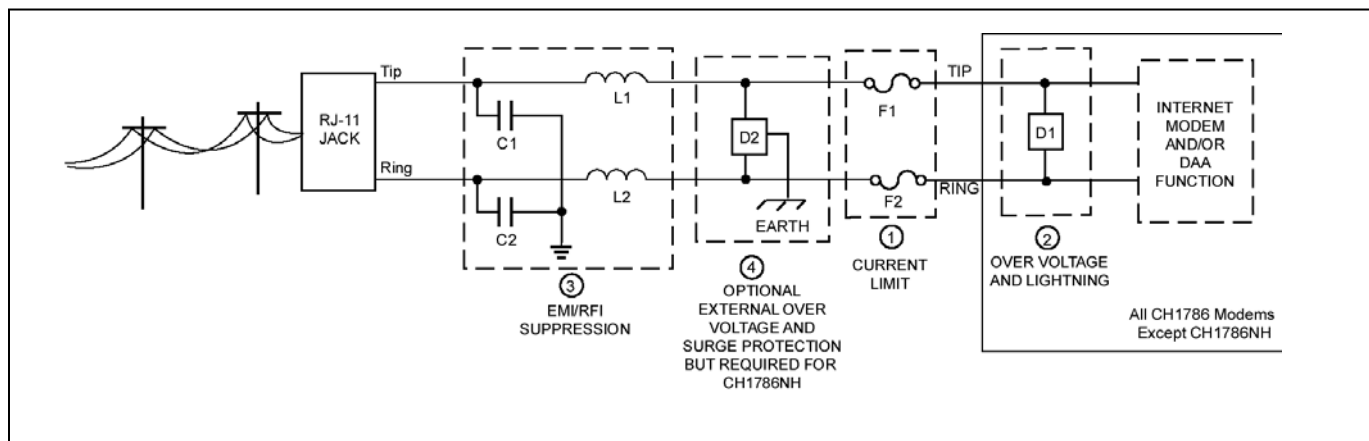

Figure 7. PSTN Line Interface for all CH1786 Products.

1. Currently Limiting PSTN Protection Line Device.

Currently limiting devices are mandatory to meet UL safety standards. To maintain conveyed FCC Part 68 approval, the current limiting components identified as F1 and F2 in dashed Box #1 must also survive FCC Part 68 surge testing. Refer to Cermetek Application Note #126, [Supplemental PSTN Line Protection](#), for more details. Refer to Application Note # 130, [Summary of Recommended Suppliers](#), for a list of suppliers and associated part numbers.

- A. A Polyfuse (rated at 0.15 amps) is preferred because it resets automatically upon removal of the current flow. Non-resettable devices are also acceptable. Refer to Application Note #130 for a complete list of recommended vendors and associated part numbers.
- B. Resistors (10Ω carbon film or 1/8 watt minimum) may be used in Canada, as Canada has no requirements that PSTN equipment be operational after a Type B surge test.
- C. Although CSA CS-03 Part 1 (Canada) follows the requirements of FCC Part 68 (USA), Cermetek recommends contacting DOT (Canada) and/or a certified independent lab to verify compliance. For Canada, use either 10Ω resistors (carbon film or SMD parts 1/8 watt minimum) as described in paragraph B above.

2. Over Voltage and Lightning Protection.

- A. Surge Protection is provided by internal circuitry contained within all CH1786 Products except the CH1786NH (see Figure 7). No additional external components are required to maintain conveyed FCC Part 68 approval for all CH1786 Products (excluding the CH1786NH).

- B. For CH1786NH, the required surge protection (identified as D1 in dashed Box 2) must be supplied externally. The purchaser must include some form of surge protection as described herein to maintain conveyed FCC Part 68 approval.

- C. In most environments, 2 terminal surge suppressors are adequate. For severe environments, use an external 3 terminal device with an earth ground.

3. EMI/RFI Suppression.

No external EMI/RFI noise suppression circuitry is required to maintain conveyed FCC Part 68 approval. However, additional suppression, if required for other reasons, may be added as described below in Sections 3A-3B without adversely affecting FCC Part 68 approval.

- A. To provide adequate EMI/RFI suppression, the capacitor/inductor network contained in dashed Box #3 should be located as close to the RJ11 Jack as possible. Further, this network should be provided with an excellent ground path to the chassis.
- B. Capacitors C1 and C2 should not exceed 0.005μf. They must have a rating of 1.5KV and typically are 0.001μf ± 20%. Inductors L1 and L2 may be either individual inductors or a dual inductor. Refer to Application Note #130 for a complete list of recommended vendors and associated part numbers. For UL applications, choose capacitors and inductors that are UL 1950 listed. The actual values of the components used may vary depending on the end product design.

Table 7. CH1786 System Data Mode Compatibility Specifications.

Parameter	Specification	Parameter	Specification
Asynchronous	2400, 1200 600 bps character asynchronous. 0-300 bps asynchronous	Receive Carrier Frequencies V.22 bis, V.22, 212A	Originate 2400Hz ± 7Hz Answer 1200Hz ± 7Hz
Asynchronous Speed Range	TXD may differ +1%, -2.5% from modem output. Offsets will be corrected by adding/deleting stop bits.	Bell 103	Answer 'space' 2020Hz ± 7Hz Answer 'mark' 2225Hz ± 7Hz Originate 'space' 1070Hz ± 7Hz Originate 'mark' 1270Hz ± 7Hz
Asynchronous Format	8,9,10 bits, including start, stop, parity.	Receiver Sensitivity	OFF to ON threshold -43 dBm ON to OFF threshold -48 dBm
Telephone Line Interface	Two-wire full duplex over public switched network. On-chip hybrid and billing delay timers.	Billing Delay	2.0 to 3.0 seconds (T _a =25°C)
Modulation	V.22 bis, 16 point QAM at 600 baud. V.22 and 212A, 4 point DPSK at 600 baud. 103 Binary phase coherent FSK.	Hysteresis	2 dB minimum
Self Test Pattern Generator	Alternate 'ones' and 'zeros' and error detector, to be used along with most loopbacks. A number indicating the bit errors detected is sent to DTE.	Line Equalization	Fixed compromise equalization, transmit. Adaptive equalizer for PSK/QAM, receive.
Transmit Carrier Frequencies V.22 bis, V.22, 212A	Originate 1200Hz ± .01% Answer 2400Hz ± .01%	Diagnostic Available	Local analog loopback. Local analog loopback. Remote digital loopback. Request remote digital loopback. Local interface loopback modem with self-test.
Bell 103	Originate 'space' 1070Hz ± .01% Originate 'mark' 1270Hz ± .01% Answer 'space' 2020Hz ± .01% Answer 'mark' 2225Hz ± .01%	Call Progress Tones Detected Computer Interface	With speaker or quiet screen messages (No dial tone, busy, ring-back, modem answer tone and voice). IBX PC/XT/AT bus compatible with an 8250/16450/16550A UART as a serial controller.

Table 8. CH1786 Electrical Specifications.

Parameter	Description	Min.	Typ.	Max.	Units
V _{CC}	Positive Supply Voltage- Noise less than 50mV	4.75	5.0	5.25	V
I _{CC} Off Hook	Nominal Operating Current when modem is OFF Hook		50	75	mA
I _{CC} On Hook	Nominal Operating Current when modem is ON Hook		25	50	mA
I _{CCPD}	Power Down Current			10	mA
V _{IH}	High Level Input Voltage*	2			V
V _{IL}	Low Level Input Voltage*	-0.3		0.8	V
I _{IN}	Input Leakage Current (TXD, DTR, RTS)	15		100	uA
I _{LO}	Leakage Current \overline{DCD} , \overline{HS} , \overline{RXD} , \overline{SLEEP} , \overline{DSR}			10	uA
C _P	Capacitive Lead (TXT, DTR, RST)			10	pF
VT+	Positive Hysteresis Threshold for RESET pin		2.5		V
VT-	Negative Hysteresis Threshold for RESET pin		1.8		V
V _{OH}	High Level (I _{OH} = 0.5mA)*	2.4			V
V _{OL}	Low Level (I _{OL} = 1.6mA)*			0.6	V

Test conditions: VCC = 5V ± 10%, Temp = 0°C to 70°F (unless otherwise stated).
***Output Load = 50 pF ± one TTL.**

Table 9. CH1786 Electrical Specifications.

Parameter	Minimum	Typical	Maximum	Units	Comments
Off Hook Impedance	20			Ohms	
Trans Hybrid Loss		25		dB	600 Ohm, RXA, TXA
Ring Voltage Loop	110V		250V	V _{pp}	On 48VDC line voltage for sustained periods
Line Loop Current-(Off-Hook)		20	100	mA	
Return Loss @ 1000Hz		15		dB	600 Ohm
Ring Frequencies		40		Hz	
Receiver Insertion Gain	-0.5	0.0	+0.5	dBm	600 Ohm- Data Mode
Transmit Power		-9.5		dB	
First Character After Reset	0.5	1.0	5	sec	Delay
Inter Character Delay	20	50		msec	Between all command characters
Command Delay	100	200		msec	Between all AT commands
Minimum Reset Pulse Duration	10			msec	If user supplied

Table 10. Other Performance Specifications.

Parameter	Minimum	Typical	Maximum	Units	Comments
Tone 2 nd Harmonic Distortion			-35	dB	HYB enabled into 600Ω
DTMF Twist (Balance)		3		dB	
DTMF Tone Duration	50		255	ms	95ms default
Pulse Dialing Rate	8	10	20	pps	10pps default
Pulse Dialing Make/ Break		39/61		%	US, Canada default
Pulse Dialing Make/ Break		33/67		%	UK, Hong Kong
Pulse Interdigit Interval	700		3000	ms	789ms default
Guard Tone Frequency		550		Hz	Referenced to High Channel Transmit
Guard Tone Amplitude		-6		dB	Referenced to High Channel Transmit
Guard Tone Frequency		1800		Hz	Referenced to High Channel Transmit
Guard Tone Amplitude		-9		dB	Referenced to High Channel Transmit
High Channel Transmit Amplitude		-1		dB	Referenced to Low channel, Guard tone enabled
Guard Tone 2 nd Harmonic Distortion		-40		dB	
Call Progress Passband Frequency	120		620	Hz	
Wait Time for Dial tone	2		255	sec	Two second default
Return loss @ 1000Hz		30		dB	$T_r=600\Omega + 2.16 \mu F$

Table 11. Analog Characteristics.

Name	Type	Characteristic	Value
SPK	O(DF)	Minimum Load	300Ω
		Maximum Capacitive Load	0.01μ
		Output Impedance	10Ω
		Output voltage	2.5± 1.6V
		D.C. Offset	<20mV

Table 12. CH1786 Pin Functions.
PACKAGE CONNECTION TABLE

PIN NO.	FUNCTION	PIN NO.	FUNCTION
1	RING	12	V/D
2	TIP	13	DTR
3	RXA	14	DSR
4	TXA	15	RI
5	SPK	16	CTS
6	NC	17	DCD
7	NC	18	HS
8	SLEEP	19	VCC
9	NC	20	GND
10	TXD	21	RST
11	RXD	22	NC

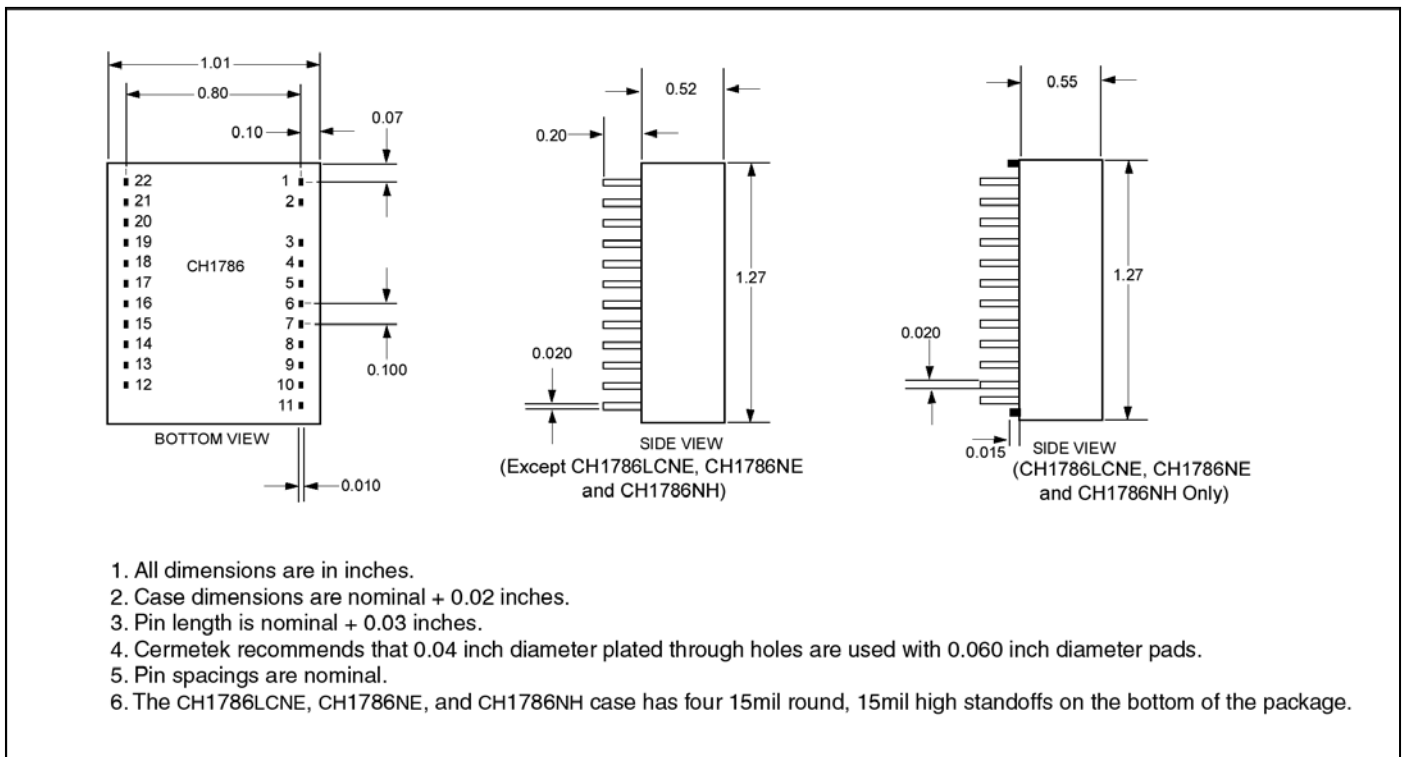

Figure 8. CH1786 Physical Dimensions.

Table 13. Summary CH1786 Family of Products.

Model	Summary of Features	Operating Temperature
CH1786	Full function, Voice/Inject, NVRAM, FCC Part 68 approved, UL 1950 Listed, Hermetic	0°C to 70°C
CH1786ET	Full function, Voice/Inject, NVRAM, Zero Power Option, FCC Part 68 Approved, UL 1950 Listed, Hermetic	-40°C to 85°C
CH1786FX	Full function, FAX, Voice/Inject, NVRAM, FCC Part 68 approved, UL 1950 Listed, Hermetic	0°C to 70°C
CH1786FXNE	Full function, FAX, Voice/Inject, NVRAM, FCC Part 68 approved, UL 1950 Listed, Non-Hermetic	0°C to 70°C
CH1786LC	Full function, Voice/Inject, FCC Part 68 Approved, UL 1950 Listed, Hermetic	0°C to 70°C
CH1786LCNE	Full function, Voice/Inject, FCC Part 68 approved, UL 1950 Listed, Non-Hermetic	0°C to 70°C
CH1786NE	Full function, Voice/Inject, NVRAM, FCC Part 68 approved, UL 1950 Listed, Non-Hermetic	0°C to 70°C
CH1786NH	Full function, FCC Part 68 Approved, Non-Hermetic, Listed UL 1950	0°C to 70°C

Cermetek reserves the right to make changes in specifications at any time and without notice. The information furnished by Cermetek in this publication is believed to be accurate and reliable. However, Cermetek assumes no responsibility for its use, or for any infringements of patents or other rights of third parties resulting from its use. No license is granted under any patents or patent rights of Cermetek.

Printed in U.S.A