

A1750A DWDM Analog Forward-Path or Return-Path Laser Module



Features

- Low adiabatic chirp
- Excellent linearity
- Standard ITU wavelengths
- Advanced analog chip design
- Tested for forward-path or return-path applications
- Reduces equipment requirements in the hub
- Exceeds *Telcordia Technologies** 468 specification.

Applications

- Networks with limited fiber
- Architectures using separate optical wavelengths to carry targeted services

* *Telcordia Technologies* is a trademark of Telcordia Technologies Inc.

Description

The A1750A laser module is a dense wavelength-division multiplexing laser with a DFB chip designed specifically for analog RF applications. The device features low adiabatic chirp to maximize signal quality in short and long lengths of fiber. The laser's excellent inherent linearity minimizes degradation of the broadcast signals caused by the QAM channels.

Wavelength-division multiplexing (WDM) has gained widespread acceptance in the telecommunications market and is being designed into emerging cable television network architectures. Dense WDM, a method for delivering targeted QAM signals to different locations, allows multiple signal sets to be combined onto a single strand of fiber for transmission from a headend to a hub. At the hub, individual QAM signals can be selected and combined with broadcast analog channels. The A1750A DWDM laser module reduces cable network architecture fiber requirements and lessens equipment requirements in the hub.

The A1750A is available at a variety of standard ITU wavelengths. The lasers are offered as either forward-path (40 MHz–860 MHz) or return-path modules (5 MHz–210 MHz).

Absolute Maximum Ratings

Stresses in excess of the absolute maximum ratings can cause permanent damage to the device. These are absolute stress ratings only. Functional operation of the device is not implied at these or any other conditions in excess of those given in the operational sections of the data sheet. Exposure to absolute maximum ratings for extended periods can adversely affect device reliability.

Parameter*	Symbol	Min	Max	Unit
Operating Case Temperature Range	TC	-25	65	°C
Storage Temperature Range	Tstg	-40	70	°C
Monitor Photodiode Reverse Voltage	VMPD	—	10	V
Laser Forward Current	IF	—	150	mA
Reverse Voltage (Laser)	VR	—	2	V
TEC Current	ITEC	-1.5	1.5	A
RF Input Power	PRFIN	—	62	dBm V

* The device can withstand continuous exposure to the specified limits without damage.

Characteristics

Table 1. Key Characteristics

Parameter	Symbol	Conditions	Min	Typ	Max	Unit
Frequency Range: ¹ Return Path Forward Path	F	—	5 40	— —	210 860	MHz MHz
Frequency Response: ¹ 5 MHz—210 MHz 40 MHz—860 MHz	S21	IF = 60 mA, TOP = 25 °C,	— —	±0.5 ±0.5	— —	dB dB
RF Return Loss: ¹ 5 MHz—210 MHz 40 MHz—860 MHz	S21	IF = 60 mA,	—	>16 >16	— —	dB dB
Optical Output Power	PO	IF = IOP	6, 8, or 10	—	—	mW
Laser Relative Intensity Noise	RIN	IF = ITH + 70 mA, T = 25 °C	—	< -155	—	dB/Hz
Composite Second Order ^{2, 3}	CSO	IF = IOP, OMI = 10%	—	< -50	—	dBc
Composite Triple Beat ^{2, 4}	CTB	IF = IOP, OMI = 10%	—	< -60	—	dBc
Available Wavelengths ⁵	λ	IP = IOP, T = TOP	1528	—	1563	nm
Wavelength Drift ⁶	ΔλOP	IF = 60 mA, T = TOP, TC varied from min—>max	—	—	0.04	nm
Adiabatic Chirp	FM	IF = 60 mA, TOP = 25 °C, measured at 500 MHz	40	—	100	MHz/mA
Operating Case Temperature Range	TC	IF = IOP	-20	—	65	°C

1. Tested in a 50 Ω system with 27 Ω series matching resistor.

2. Eight-channel loading, 10% OMI, 40 km fiber.

3. Measured at 42 MHz.

4. Measured at 553.25 MHz, 577.25 MHz, and 595.25 MHz.

5. Consult an Agere Systems account manager for other wavelengths.

6. Change in wavelength as case temperature is changed.

Characteristics (continued)

Table 2. Additional Characteristics

Parameter	Symbol	Conditions	Min	Max	Unit
Bias Current ¹ (Operating Current)	I _B	BOL	—	120	mA
Threshold Current	I _{TH}	25 °C, BOL	—	30	mA
Slope Efficiency ²	η	I _P = I _{TH} + 20 and I _{TH} + 60	0.10	—	mW/mA
Monitor Photocurrent	I _{MON}	I _{OP} = 0 mA, V _{RM} = 5 V, T _{OP} = 25 °C	10	200	μA/mW
Operating Chip Temperature ³	T _{OP}	I _F = I _{OP}	15	35	°C
TEC Current	I _{TEC}	-20 °C < T _c < 65 °C, T _{OP} = 15 °C—35 °C, I _F = 60 mA	-1.5	1.5	A
TEC Voltage	V _{TEC}	T _{OP} = 15 °C—35 °C over T _c	-2	2	V
Thermistor Resistance	R _{TH}	T _{OP} = 25 °C	9.5	10.5	kΩ
Optical Return Loss	ORL	T _c	40	—	dB
Side Mode Suppression Ratio	SMSR	I _F = I _{OP}	30	—	dB

1. Bias point at which all specifications apply.
2. For 10 mW output power. Minimum slope efficiency is lower for lower power lasers.
3. Chip temperature at which wavelength specification is met. Operating chip temperature is reported for each laser.

Electrical Schematics

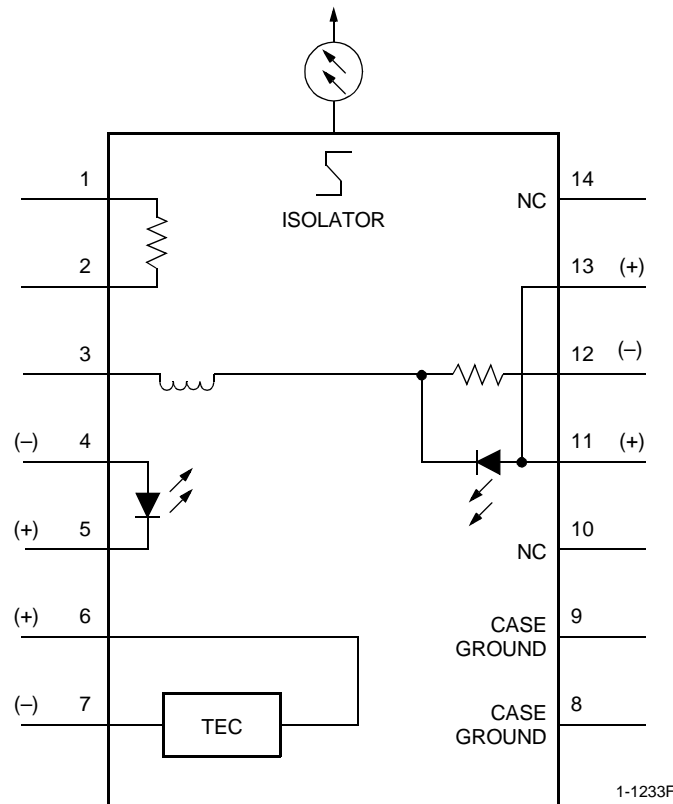

Figure 1. A1750A Laser Schematic

Electrical Schematics (continued)

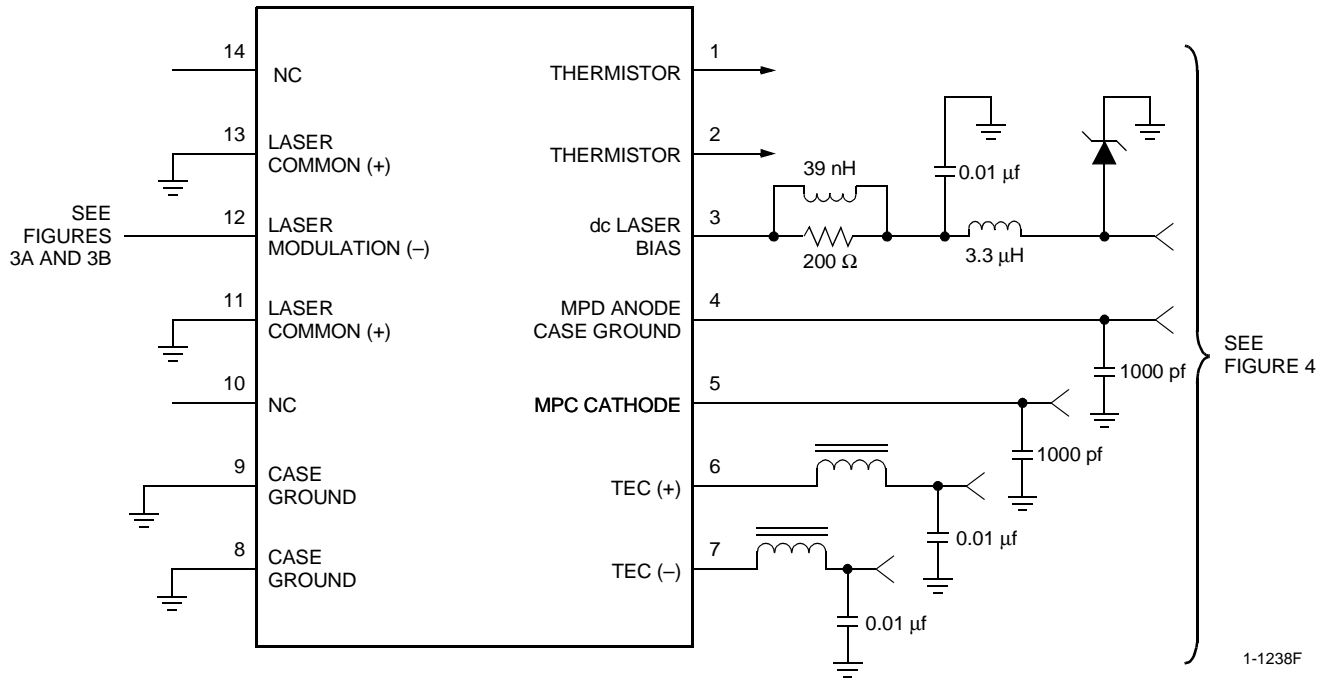
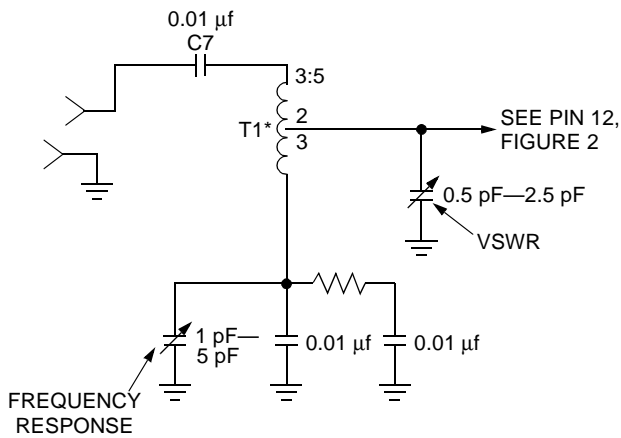

Figure 2. A1750A Circuit Schematic



* T1 (75 Ω) 3:5.

1-1238a(F)

Figure 3a. Impedance-Matched Configuration

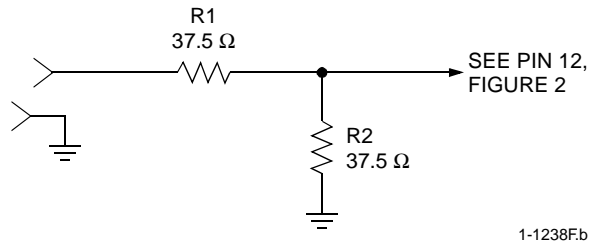
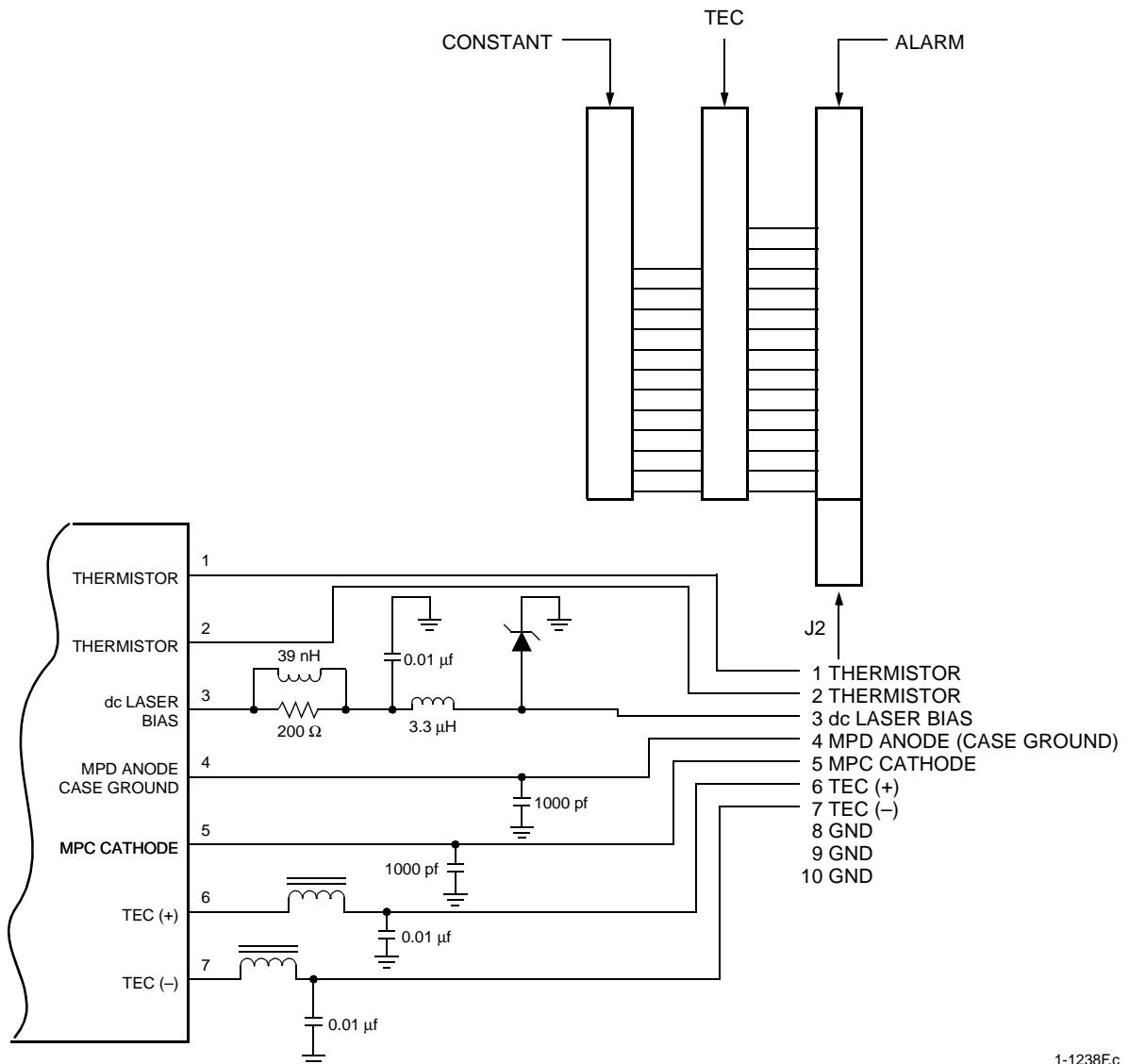

Figure 3b. Resistive-Matched Configuration

Electrical Schematics (continued)



Note: When ordering the dc set, the following boards are included: alarm board, 9108-004; TEC board, 9028-004; constant current, 9383-004.

Figure 4. dc Set (Agere Systems-Supplied Option)

Outline Diagram

Dimensions are in inches and (millimeters).

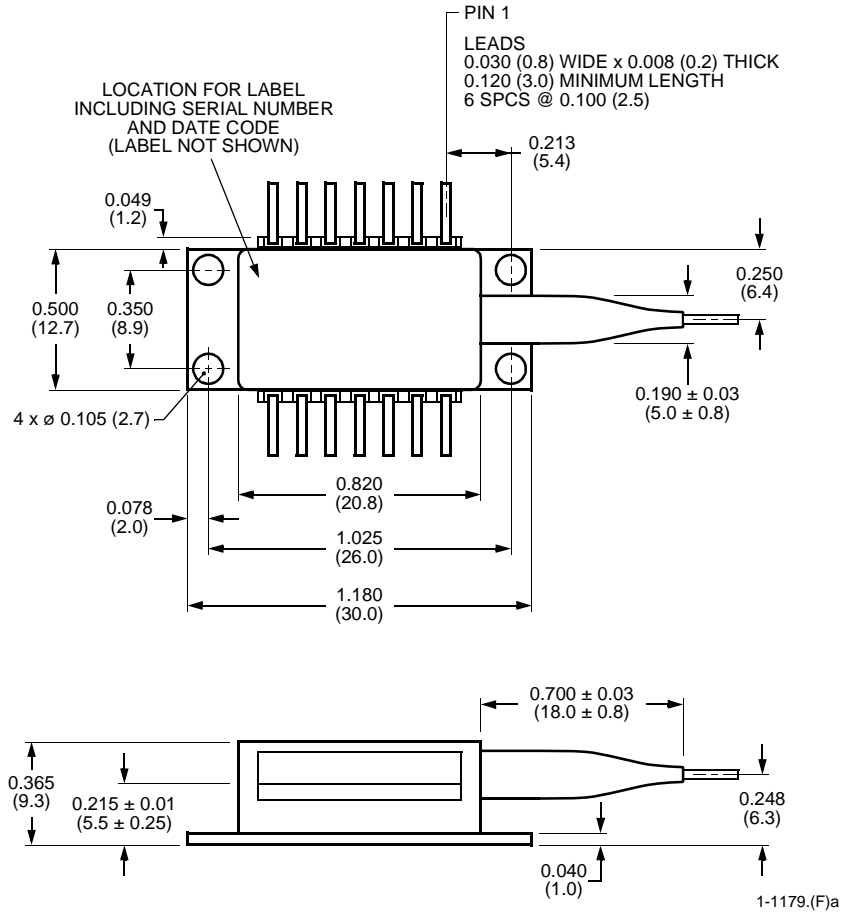

Pin Information

Table 3. Pin Descriptions

Pin No.	Description
1	Thermistor
2	Thermistor
3	dc Laser Bias (-)
4	MPD Anode, Case Ground
5	MPD Cathode
6	Thermoelectric Cooler (+)
7	Thermoelectric Cooler (-)
8	Case Ground
9	Case Ground
10	NC
11	Laser Common (+)
12	Laser Modulation (-)
13	Laser Common (+)
14	NC

Laser Safety Information

Class IIIb Laser Product

FDA/CDRH Class IIIb laser product. All versions are Class IIIb laser products per CDRH, 21 CFR 1040 Laser Safety requirements. All versions are Class 3B laser products per IEC* 60825-1:1993. The device has been classified with the FDA under an accession number to be determined.

This product complies with 21 CFR 1040.10 and 1040.11.
Single-mode fiber pigtail with SC/APC connectors (standard)
Wavelength = 1.5 μ m
Maximum power = 30 mW

Because of size constraints, laser safety labeling (including an FDA Class IIIb label) is not affixed to the module but attached to the outside of the shipping carton.

Product is not shipped with power supply.

Caution: Use of controls, adjustments, and procedures other than those specified herein may result in hazardous laser radiation exposure.

* IEC is a registered trademark of The International Electrotechnical Commission.

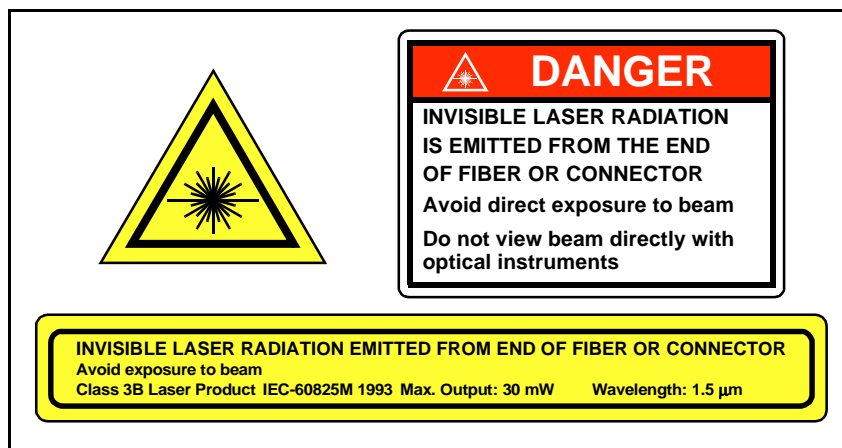

Ordering Information

Table 4. Ordering Information*

Device Code	Description	Connector	Comcode
A1750A (See Device Code Definitions, next page.)	DWDM Forward- or Return-Path Laser Modules	SC/APC standard; FC/APC available	TBD

* For additional ordering information, please contact an Agere Systems account manager at Opto West, 1-800-362-3891 (for sales staff, please press option 2).

Ordering Information (continued)

Ordering Code Definitions

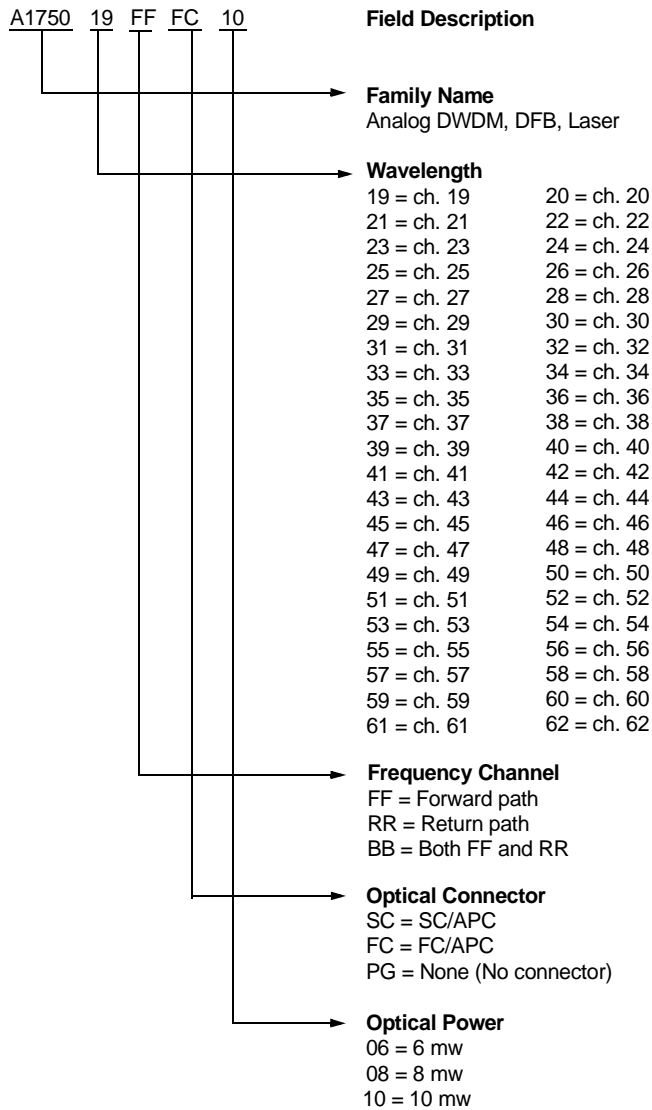

For additional information, contact your Agere Systems Account Manager or the following:

INTERNET: <http://www.agere.com>

E-MAIL: docmaster@micro.lucent.com

N. AMERICA: Agere Systems Inc., 555 Union Boulevard, Room 30L-15P-BA, Allentown, PA 18109-3286

1-800-372-2447, FAX 610-712-4106 (In CANADA: **1-800-553-2448**, FAX 610-712-4106)

ASIA PACIFIC: Agere Systems Singapore Pte. Ltd., 77 Science Park Drive, #03-18 Cintech III, Singapore 118256

Tel. (65) 778 8833, FAX (65) 777 7495

CHINA: Agere Systems (Shanghai) Co., Ltd., 33/F Jin Mao Tower, 88 Century Boulevard Pudong, Shanghai 200121 PRC

Tel. (86) 21 50471212, FAX (86) 21 50472266

JAPAN: Agere Systems Japan Ltd., 7-18, Higashi-Gotanda 2-chome, Shinagawa-ku, Tokyo 141, Japan

Tel. (81) 3 5421 1600, FAX (81) 3 5421 1700

EUROPE: Data Requests: DATALINE: **Tel. (44) 7000 582 368**, FAX (44) 1189 328 148

Technical Inquiries: OPTOELECTRONICS MARKETING: **(44) 1344 865 900** (Ascot UK)

Agere Systems Inc. reserves the right to make changes to the product(s) or information contained herein without notice. No liability is assumed as a result of their use or application.