

Speech network for telephones

BA8216

The BA8216 is a speech network IC which possesses the basic functions required for handset communications. In addition to amplifying signals from a transmitter and sending them to a telephone line, it also amplifies only reception signals from a telephone line and drives the receiver.

● Applications

Telephones and telephone equipment

● Features

- 1) Basic speech network functions built in.
 - Handset transmit and receive circuits
 - DTMF transmit circuit
 - Key tone input circuit
 - Mute control and side tone masking circuits
- 2) Can be used with 1.3k Ω loop circuit resistance and 100 Ω telephone resistance.
- 3) A BTL circuit is used for reception output, providing a wide dynamic range which enables use of a ceramic receiver.
- 4) Few external components required.
- 5) 14-pin DIP package.

● Block diagram

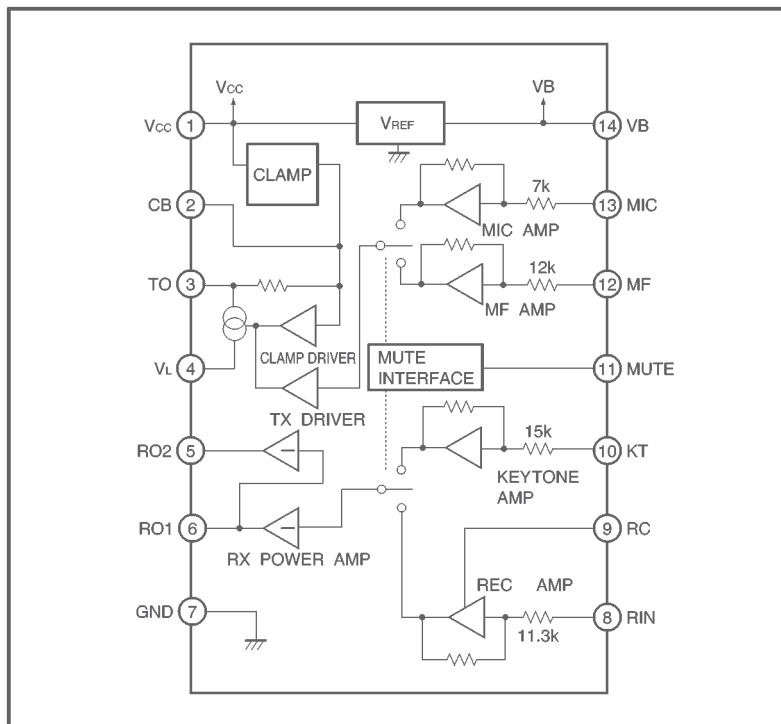

● Absolute maximum ratings (Ta = 25°C)

Parameter	Symbol	Limits	Unit
Applied voltage	V _L	18	V
Current dissipation	I _L	135	mA
Power dissipation	P _d	900 *	mW
Operating temperature	T _{opr}	-25~+75	°C
Storage temperature	T _{stg}	-55~+125	°C

* Reduced by 9 mW for each increase in Ta of 1°C over 25°C.

●Electrical characteristics (unless otherwise noted, Ta = 25°C, S1 = 1, S2 =1, f = 1kHz, BPF = 400Hz to 30kHz)

Parameter		Symbol	Min.	Typ.	Max.	Unit	I _L (mA)	Conditions	Measurement circuit	
Line voltage (20)		V _{L20}	3.8	4.15	4.5	V	20		Fig.11	
Line voltage (120)		V _{L120}	4.1	4.6	5.5	V	120			
Input high level voltage		V _{IH}	0.8	—	—	V	40	S ₂ =2		
Input low level voltage		V _{IL}	—	—	0.5	V	40	S ₂ =2		
Input high level current		I _{IH}	100	200	300	μA	40	S ₂ =2, V _{IH} =4V		
Electromagnetic	Receive	Gain	G _{RD}	-13.8	-10.8	-7.8	dB	40	V _T =20dBV	Fig.12
		Maximum output	V _{RD}	-19	-15	—	dBV	20	THD=5%	
		Input impedance	Z _{RIN}	8.3	11.3	14.3	kΩ	40		
	KT	Gain	G _{KTD}	10.5	13.5	16.5	dB	40	S ₂ =3, V _{KT} =-40dBV	Fig.12
		Maximum output	V _{KTD}	-19	-15	—	dBV	20	S ₂ =3, THD=5%	
		Input impedance	Z _{KT}	11	15	19	kΩ	40		
Piezoelectric	Receive	Gain	G _{RP}	0.9	3.9	6.9	dB	40	S ₁ =2, V _T =-20dBV	Fig.12
		Maximum output	V _{RP}	1	5	—	dBV	20	S ₁ =2, THD=5%	
		Input impedance	Z _{RIN}	8.3	11.3	14.3	kΩ	40		
	KT	Gain	G _{KTP}	25.1	28.1	31.1	dB	40	S ₁ =2, S ₂ =3, V _{KT} =-40dBV	Fig.12
		Maximum output	V _{KTP}	1	5	—	dBV	20	S ₁ =2, S ₂ =3, THD=5%	
		Input impedance	Z _{KT}	11	15	19	kΩ	40		
Transmit	MIC	Gain	G _{MIC}	19.6	22.6	25.6	dB	40	V _M =-40dBV	Fig.13
		Maximum output	V _{MIC}	0	4	—	dBV	20	THD=5%	
		Input impedance	Z _{MIC}	5	7	9	kΩ	40		
	MF	Gain	G _{MF}	21.1	24.1	27.1	dB	40	S ₂ =3, V _D =-40dBV	Fig.13
		Maximum output	V _{MF}	0	4	—	dBV	15	S ₂ =3, THD=5%	
		Input impedance	Z _{MF}	9	12	15	kΩ	40		
Mute ratio *		MR _{RD}	30	35	—	dB	40	V _T =-20dBV, S ₂ =1→3	Fig.12	
		MR _{RP}	30	35	—	dB	40	V _T =-20dBV, S ₂ =1→3, S ₁ =2		
		MR _{MIC}	60	67	—	dB	40	V _M =-40dBV, S ₂ =1→3	Fig.13	
		MR _{MF}	60	67	—	dB	40	V _D =-40dBV, S ₂ =3→1		
Attenuation during branch		ΔG _{RD}	—	-6	—	dB	—	See Fig. 14	Fig.14	
		ΔG _{RP}	—	-5	—	dB	—	See Fig. 14		
		ΔG _{MIC}	—	-15	—	dB	—	See Fig. 14		
Noise level		N _{RD}	—	-75	—	dBV	120	V _T =0	Fig.12	
		N _{RP}	—	-73	—	dBV	120	S ₁ =2, V _T =0		
		N _{MIC}	—	-74	—	dBV	120	V _M =0	Fig.13	
		N _{MF}	—	-71	—	dBV	120	S ₂ =3, V _D =0		

* When using 1 kHz bandpass filter

●Electrical characteristic curves

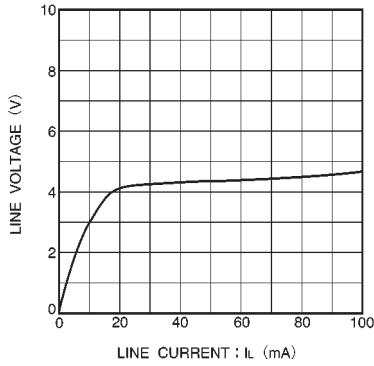

Fig. 1 Line voltage vs. line current

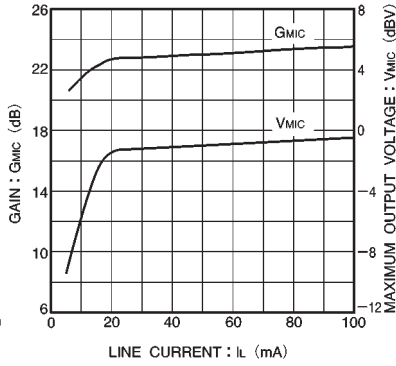

Fig. 2 MIC Line current

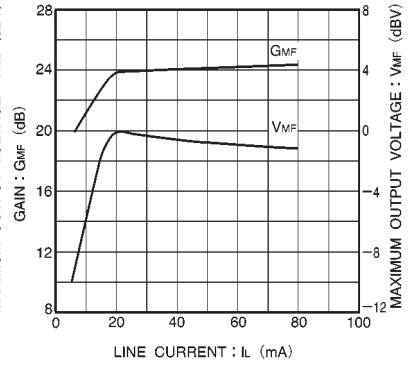

Fig. 3 MF Line current

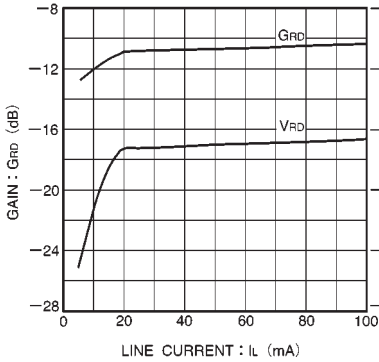

Fig. 4 Electromagnetic receiving Line current

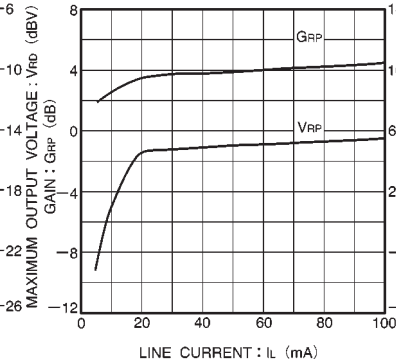

Fig. 5 Piezoelectric receiving Line current

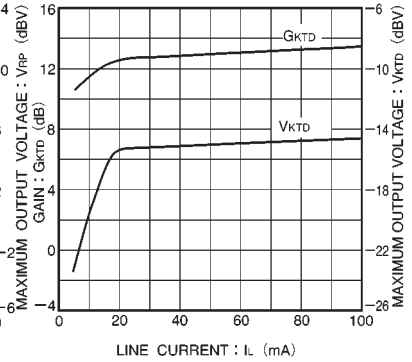

Fig. 6 Electromagnetic KT Line current

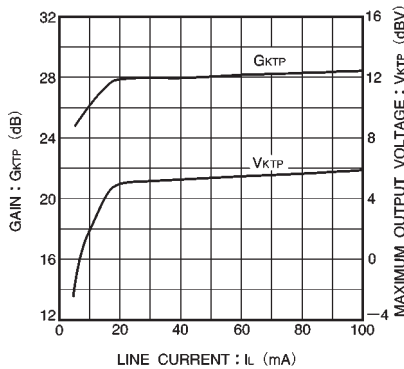

Fig. 7 Piezoelectric KT Line current

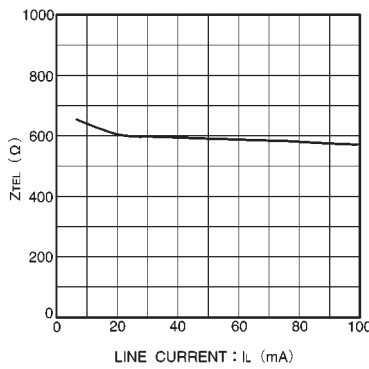

Fig. 8 AC impedance Line current

● Measurement circuits

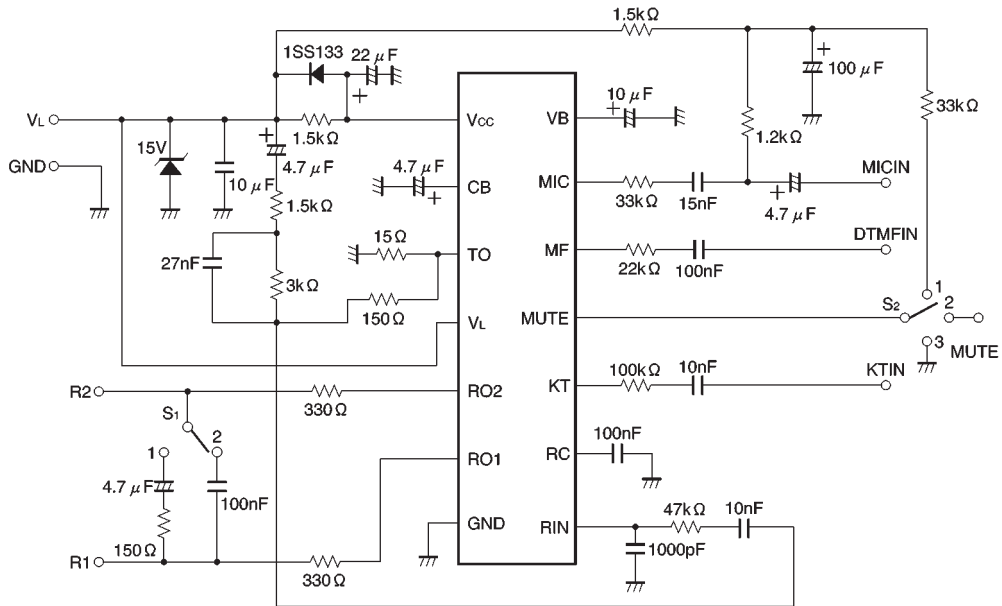

Fig. 9 Basic measurement circuit

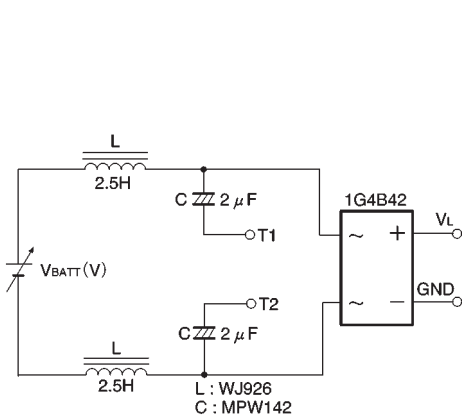

Fig. 10 Trunk circuit

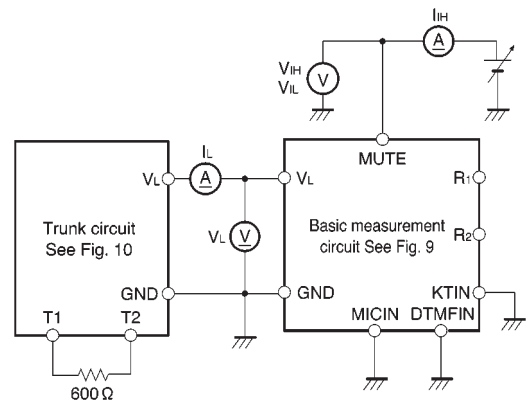

Fig. 11 DC characteristics measurement circuit

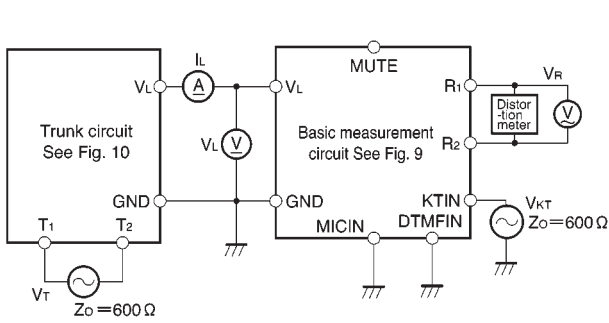

Fig. 12 Reception system measurement circuit

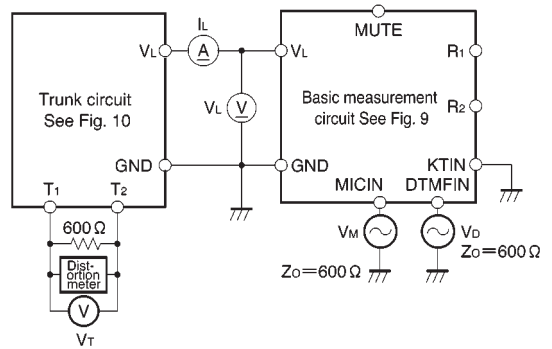

Fig. 13 Transmission system measurement circuit

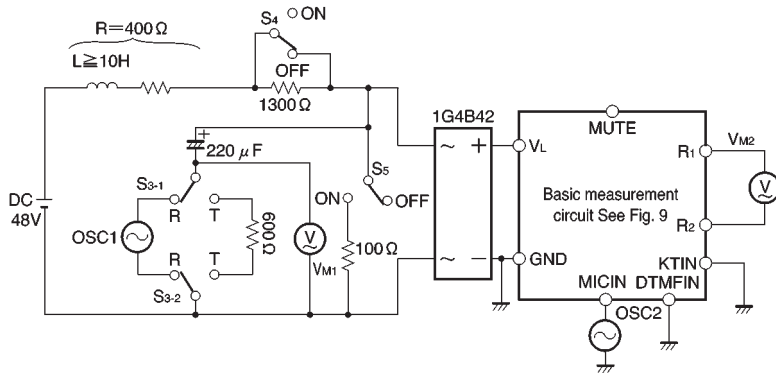

Fig. 14 Branch measurement circuit

● Measurement method (MUTE = HIGH)

(1) Reception

1) Set S_3 to R and S_4 and S_5 to OFF, and input a 1kHz signal from OSC1. Adjust to -10dBV if V_{M2} is piezoelectric, and to -30dBV if V_{M2} is electromagnetic.

2) With S_4 OFF and S_5 ON, record the output level of V_{M2} and note this value as V_{M2} (2).

3) With S_4 ON and S_5 ON, measure the output level of V_{M2} , and note this value as V_{M2} (3).

$$\Delta G_R = 20 \log (V_{M2} \text{ (3)} / V_{M2} \text{ (2)})$$

(2) Transmission

1) Set S_3 = T and S_4 and S_5 to OFF, input a 1kHz signal from OSC2, and adjust so that V_{M1} is -10dBV.

2) With S_4 OFF and S_5 ON, record the output level of V_{M1} and note this value as V_{M1} (2).

3) With S_4 ON and S_5 ON, measure the output level of V_{M1} , and note this value as V_{M1} (3).

$$\Delta G_{MIC} = 20 \log (V_{M1} \text{ (3)} / V_{M1} \text{ (2)})$$

S_3 : Send and receive switch (reception side)

S_4 : ON/OFF switch for line resistance (1300 Ω) (OFF)

S_5 : ON/OFF switch for parallel resistance (100 Ω) (OFF)

● Circuit operation

The BA8216 carries out the following basic operations.

(1) Handset talk and receive

The BA8216 receives a voice signal from a telephone line and outputs it to a handset speaker. It also takes a voice signal from the handset microphone and outputs it to the telephone line.

(2) DTMF send and key tone input

The BA8216 has a mute switch which can be switched between a "handset send and receive" mode and a "DTMF send and key tone input" mode by an external logic signal. In the "DTMF send and key tone input" mode, it transmits DTMF signals from the dial pad to the telephone line, and key tones to the handset receiver.

● Operation notes

The maximum power dissipation for the BA8216 is 900mW. Since the maximum power dissipation varies with temperature, the product of the applied voltage V_L and the total current drawn by the IC, after factoring in the temperature, should not exceed the maximum dissipation.

● Pin descriptions

Pin No.	Symbol	Name	Function
1	V _{CC}	Internal power supply pin	Internal power supply pin. Power is supplied from V _L through resistor R ₁₀₁ , and is smoothed by capacitor C ₁₀₁ .
2	CB	Bypass capacitor connector pin	This is used to connect an AC bypass capacitor to form a DC feedback loop for stabilizing the DC potential of the V _L pin.
3	TO	Transmit/power dissipation resistor connector pin	This is connected between the power dissipation resistor R ₁₀₅ and the GND, to eliminate unnecessary power consumption. At the same time, R ₁₀₅ determines the gain of the final output stage of the transmission driver. R ₁₀₄ and R ₁₀₅ form two legs of the side tone suppression bridge, which is also connected to this pin.
4	V _L	V _L pin	This is the power supply pin. The transmit signal is output to the telephone line through this pin. It is connected to the (+) side of the diode bridge.
5	RO ₂	Receive output pin	When a piezoelectric receiver is used, connect a 330- protection resistor R ₁₉₁ to this pin. When a dynamic receiver is used, R ₁₉₁ may be 0 Ω.
6	RO ₁	Receive output pin	When a piezoelectric receiver is used, connect a 330- protection resistor R ₁₀₆ to this pin. C ₁₉₁ is shorted. When a dynamic receiver is used, a 4.7 μF DC blocking capacitor (C ₁₉₁) is connected in series with the 680 Ω resistor (R ₁₀₆) to this pin.
7	GND	Ground pin	This pin has the lowest potential on the IC. It is connected to the (−) pin of the diode bridge.
8	RIN	Receive input pin	After passing through a side tone suppression circuit, the receive signal from the telephone line is input to this pin.
9	RC	Receive amplifier bypass capacitor pin	This is connected to the AC bypass capacitor of the reception amplifier.
10	KT	Key tone input pin	When the MUTE pin is low, key tone signals input on this pin are transmitted to the handset speaker.
11	MUTE	Mute input pin	When this is high, hand-set transmission is normal. When this is low, DTMF signals applied at the MF input are output to the telephone line, and key tones applied to the KT pin are transmitted to the hand receiver.
12	MF	DTMF signal input pin	When the MUTE pin is low, DTMF signals input to this pin are output to the telephone line.
13	MIC	Microphone input pin	Used to input signals from the microphone.
14	VB	Bias pin	This is the IC internal bias pin. It is connected to the bypass capacitor C ₁₁₁ .

● Pin assignments

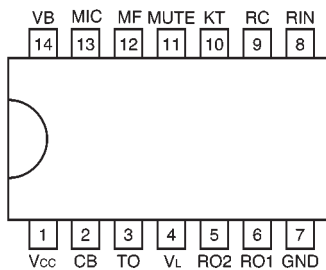

Mute control input logic

MUTE	MIC AMP	MF AMP	REC AMP	KT AMP
H	ON	OFF	ON	OFF
L	OFF	ON	OFF	ON

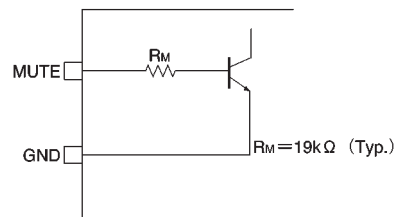

Fig. 15 Mute input equivalent circuit

●Application example

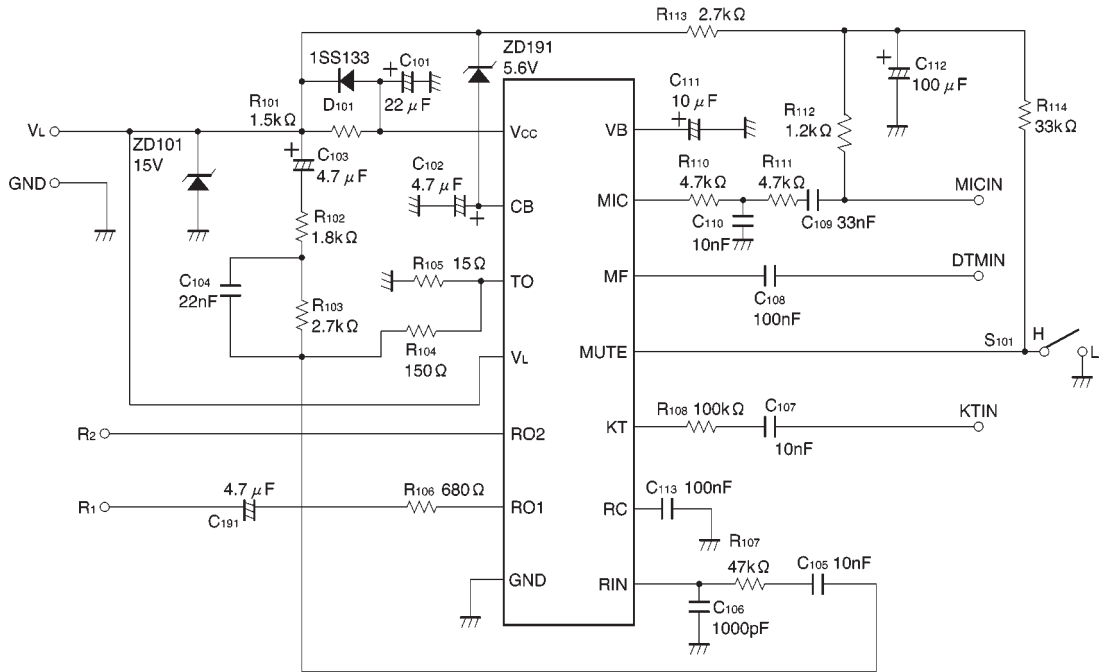

Fig. 16

●External dimensions (Units: mm)

