

CMOSH-3
ULTRAmiji™
SURFACE MOUNT
SCHOTTKY DIODES

ULTRAmiji™



SOD-523 CASE

Central™
Semiconductor Corp.

DESCRIPTION:

The CENTRAL SEMICONDUCTOR CMOSH-3 type is a Silicon Schottky diode, epoxy molded in an ULTRAmiji™ surface mount package, designed for fast switching applications requiring a low forward voltage drop. Marking code is **53**.

MAXIMUM RATINGS: ($T_A=25^\circ\text{C}$)

	SYMBOL		UNITS
Peak Repetitive Reverse Voltage	V_{RRM}	30	V
Continuous Forward Current	I_F	100	mA
Peak Repetitive Forward Current	I_{FRM}	350	mA
Forward Surge Current, $t_p=10\text{ms}$	I_{FSM}	750	mA
Power Dissipation	P_D	250	mW
Operating and Storage			
Junction Temperature	T_J, T_{stg}	-65 to +150	$^\circ\text{C}$
Thermal Resistance	θ_{JA}	500	$^\circ\text{C/W}$

ELECTRICAL CHARACTERISTICS: ($T_A=25^\circ\text{C}$ unless otherwise noted)

SYMBOL	TEST CONDITIONS	MIN	TYP	MAX	UNITS
B_{VR}	$I_R=100\mu\text{A}$	30			V
V_F	$I_F=2.0\text{mA}$		0.29	0.33	V
V_F	$I_F=15\text{mA}$		0.40	0.45	V
V_F	$I_F=100\text{mA}$		0.74	1.00	V
I_R	$V_R=25\text{V}$		90	500	nA
I_R	$V_R=25\text{V}, T_A=100^\circ\text{C}$		25	100	μA
C_T	$V_R=1.0\text{V}, f=1\text{ MHz}$		7.0		pF
t_{rr}	$I_F=I_R=10\text{mA}, I_{rr}=1.0\text{mA}, R_L=100\Omega$			5.0	ns

R1 (20-July 2001)

SOD-523 - MECHANICAL OUTLINE

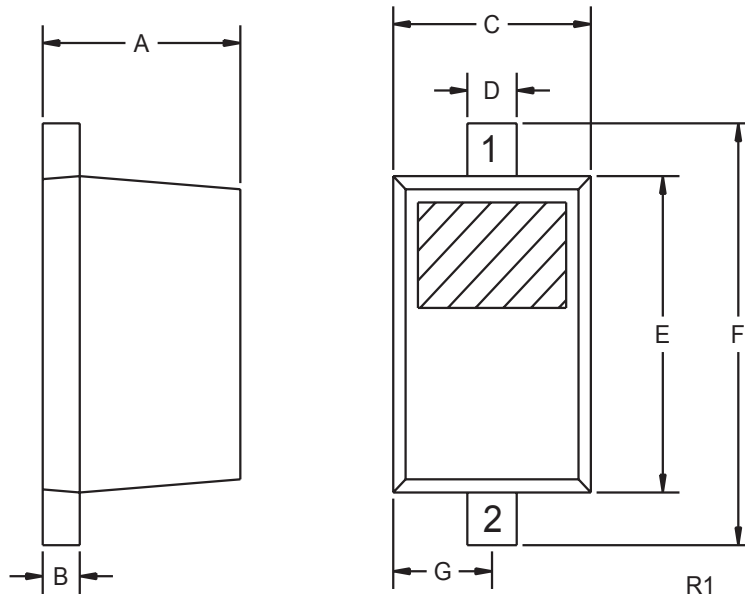

Lead Code:

- 1) Cathode
- 2) Anode

MARKING CODE: 53

SYMBOL	DIMENSIONS			
	INCHES		MILLIMETERS	
	MIN	MAX	MIN	MAX
A	0.020	0.031	0.50	0.80
B	0.004	0.008	0.10	0.20
C	0.028	0.035	0.70	0.90
D	0.008	0.011	0.20	0.28
E	0.039	0.055	1.00	1.40
F	0.055	0.071	1.40	1.80
G	0.016		0.40	

SOD-523 (REV: R1)

R1 (20-July 2001)