

A3212

MICROPOWER, ULTRA-SENSITIVE HALL-EFFECT SWITCH

Package Suffix 'LH' Pinning (SOT23W)

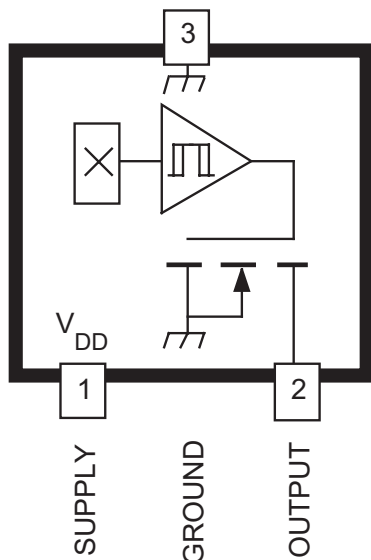

Dwg. PH-016-1

Pinning is shown viewed from branded side.

ABSOLUTE MAXIMUM RATINGS

Supply Voltage, V_{DD}	5 V
Magnetic Flux Density, B	Unlimited
Output Off Voltage, V_{OUT}	5 V
Output Current, I_{OUT}	1 mA
Junction Temperature, T_J	+170°C
Operating Temperature, T_A	
Range 'E'	-40°C to +85°C
Range 'L'	-40°C to +150°C
Storage Temperature Range,	
T_S	-65°C to +170°C

Caution: These CMOS devices have input static protection (Class 3) but are still susceptible to damage if exposed to extremely high static electrical charges.

The A3212 integrated circuit is an ultra-sensitive, pole independent Hall-effect switch with a latched digital output. This sensor is especially suited for operation in battery-operated, hand-held equipment such as cellular and cordless telephones, pagers, and palmtop computers. A 2.5 volt to 3.5 volt operation and a unique clocking scheme reduce the average operating power requirements to less than 15 μ W with a 2.75 volt supply.

Unlike other Hall-effect switches, either a north or south pole of sufficient strength will turn the output on; in the absence of a magnetic field, the output is off. The polarity independence and minimal power requirement allow these devices to easily replace reed switches for superior reliability and ease of manufacturing, while eliminating the requirement for signal conditioning.

Improved stability is made possible through chopper stabilization (dynamic offset cancellation), which reduces the residual offset voltage normally caused by device overmolding, temperature dependencies, and thermal stress.

This device includes on a single silicon chip a Hall-voltage generator, small-signal amplifier, chopper stabilization, a latch, and a MOSFET output. Advanced BiCMOS processing is used to take advantage of low-voltage and low-power requirements, component matching, very low input-offset errors, and small component geometries.

Three package styles provide a magnetically optimized package for most applications. Package suffixes 'EH' and 'LH' are for miniature low-profile (leadless and leaded, respectively) surface-mount packages while suffix 'UA' is for a three-lead SIP for through-hole mounting. Each package is available in a lead (Pb) free version (suffix, -T) with 100% matte tin plated leadframe.

FEATURES

- Micropower Operation
- Operation with North or South Pole
- 2.5 V to 3.5 V Battery Operation
- Chopper Stabilized
 - Superior Temperature Stability
 - Extremely Low Switch-Point Drift
 - Insensitive to Physical Stress
- ESD Protected to 5 kV
- Solid-State Reliability
- Small Size
- Easily Manufacturable with Magnet Pole Independence



**A3212
MICROPOWER,
ULTRA-SENSITIVE
HALL-EFFECT SWITCH**

Product Selection Guide

Use complete part numbers when ordering

Part Number	Pb-free	Packing* (Units/Pack)	Package	Ambient Temperature T _A (°C)	
A3212EEHLT	–	Tape and Reel (3000)	Leadless Surface Mount	–40 to 85	
A3212EEHLT–T	Yes	Tape and Reel (3000)			
A3212ELHLT	–	Tape and Reel (3000)	3-Pin Surface Mount		
A3212ELHLT–T	Yes	Tape and Reel (3000)			
A3212EUA	–	Bulk Pack (500)	SIP-3 Through Hole, Straight Lead		
A3212EUA–T	Yes	Bulk Pack (500)			
A3212LLHLT	–	Tape and Reel (3000)	3-Pin Surface Mount		–40 to 150
A3212LLHLT–T	Yes	Tape and Reel (3000)			
A3212LUA	–	Bulk Pack (500)	SIP-3 Through Hole, Straight Lead		
A3212LUA–T	Yes	Bulk Pack (500)			

*Contact Allegro for additional packaging and handling options.

3212 MICROPOWER, ULTRA-SENSITIVE HALL-EFFECT SWITCH

FUNCTIONAL BLOCK DIAGRAM

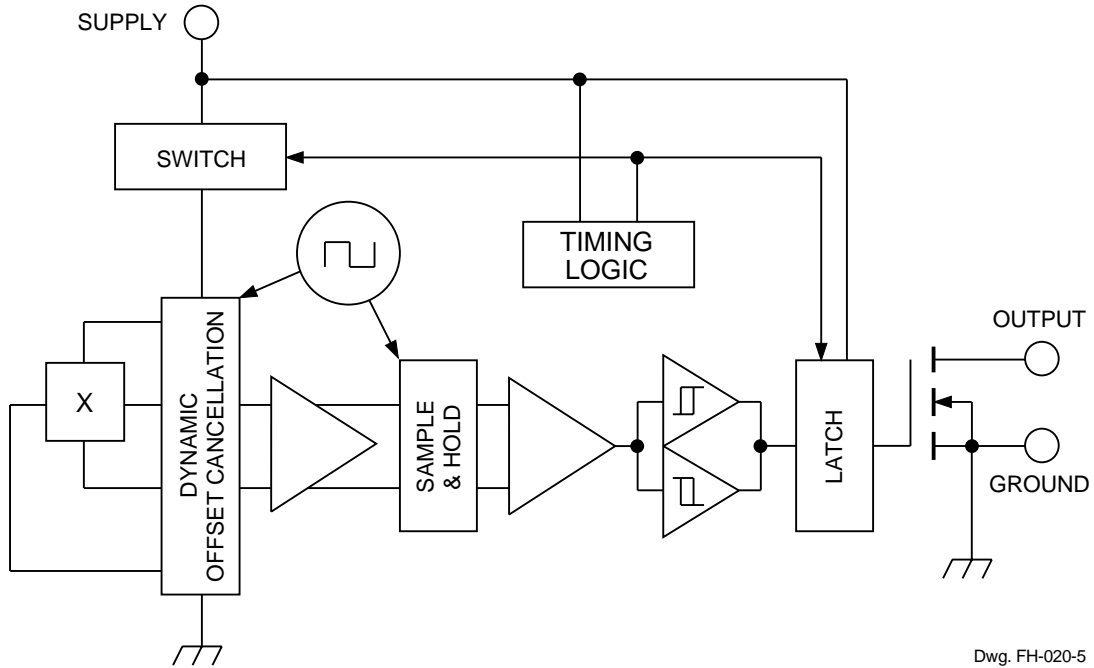

Package Suffix 'EH' Pinning (Leadless Chip Carrier)

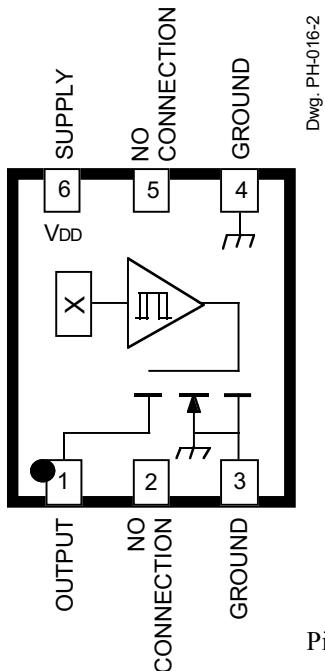

Package Suffix 'UA' Pinning (SIP)

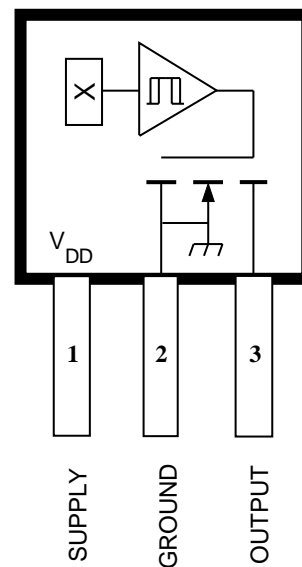

Pinning is shown viewed from branded side.

A3212

MICROPOWER, ULTRA-SENSITIVE HALL-EFFECT SWITCH

ELECTRICAL CHARACTERISTICS over operating voltage and temperature range (unless otherwise specified).

Characteristic	Symbol	Test Conditions	Limits			
			Min.	Typ.	Max.	Units
Supply Voltage Range	V_{DD}	Operating ¹	2.5	2.75	3.5	V
Output Leakage Current	I_{OFF}	$V_{OUT} = 3.5\text{ V}$, $B_{RPN} < B < B_{RPS}$	–	<1.0	1.0	μA
Output On Voltage	V_{OUT}	$I_{OUT} = 1\text{ mA}$, $V_{DD} = 2.75\text{ V}$	–	100	300	mV
Awake Time	t_{awake}		–	45	90	μs
Period	t_{period}		–	45	90	ms
Duty Cycle	d.c.		–	0.1	–	%
Chopping Frequency	f_C		–	340	–	kHz
Supply Current	$I_{DD(EN)}$	Chip awake (enabled)	–	–	2.0	mA
	$I_{DD(DIS)}$	Chip asleep (disabled)	–	–	8.0	μA
	$I_{DD(AVG)}$	$V_{DD} = 2.75\text{ V}$	–	5.1	10	μA
		$V_{DD} = 3.5\text{ V}$	–	6.7	10	μA

- NOTES: 1. Operate and release points will vary with supply voltage.
 2. B_{OPx} = operate point (output turns on); B_{RPx} = release point (output turns off).
 3. Typical Data is at $T_A = +25^\circ\text{C}$ and $V_{DD} = 2.75\text{ V}$ and is for design information only.

MAGNETIC CHARACTERISTICS over operating voltage and temperature range (unless otherwise specified).

Characteristic	Symbol	Test Conditions	Limits			
			Min.	Typ.	Max.	Units
Operate Points	B_{OPS}	South pole to branded side	–	37	55	G
	B_{OPN}	North pole to branded side	-55	-40	–	G
Release Points	B_{RPS}	South pole to branded side	10	31	–	G
	B_{RPN}	North pole to branded side	–	-34	-10	G
Hysteresis	B_{hys}	$ B_{OPx} - B_{RPx} $	–	5.9	–	G

- NOTES: 1. Negative flux densities are defined as less than zero (algebraic convention), i.e., -50 G is less than +10 G.
 2. B_{OPx} = operate point (output turns on); B_{RPx} = release point (output turns off).
 3. Typical Data is at $T_A = +25^\circ\text{C}$ and $V_{DD} = 2.75\text{ V}$ and is for design information only.
 4. 1 gauss (G) is exactly equal to 0.1 millitesla (mT).

3212 MICROPOWER, ULTRA-SENSITIVE HALL-EFFECT SWITCH

TYPICAL OPERATING CHARACTERISTICS

SWITCH POINTS

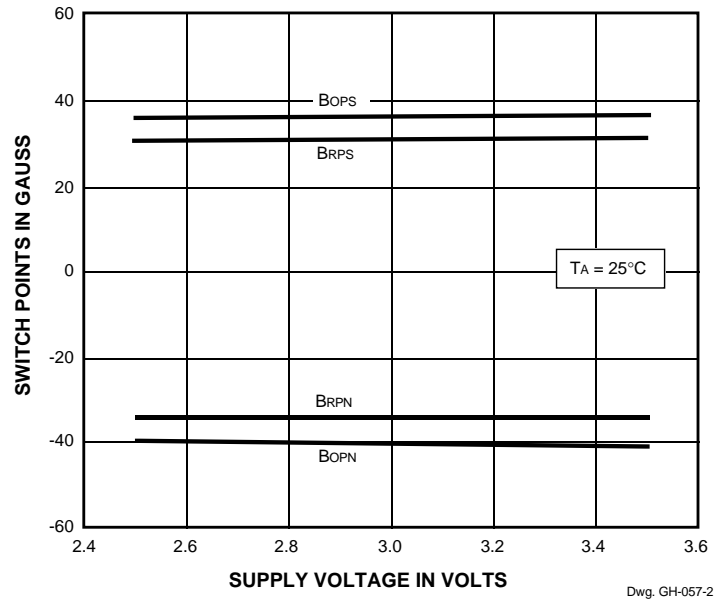
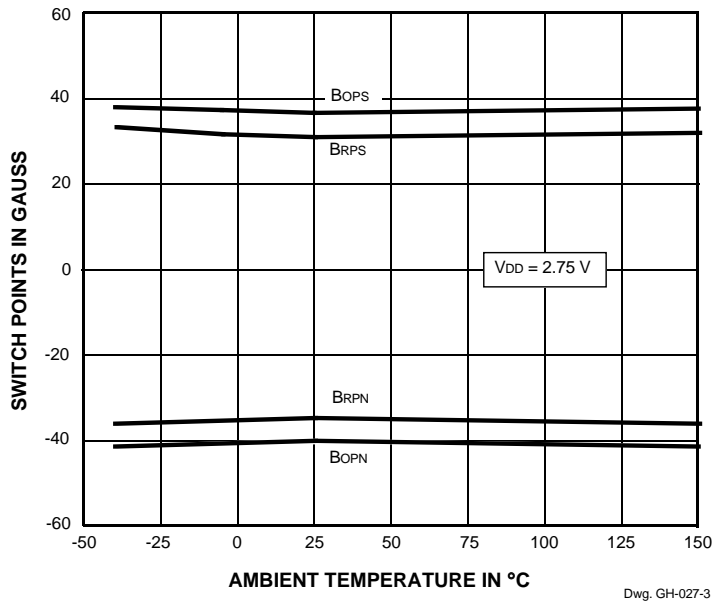

SUPPLY CURRENT

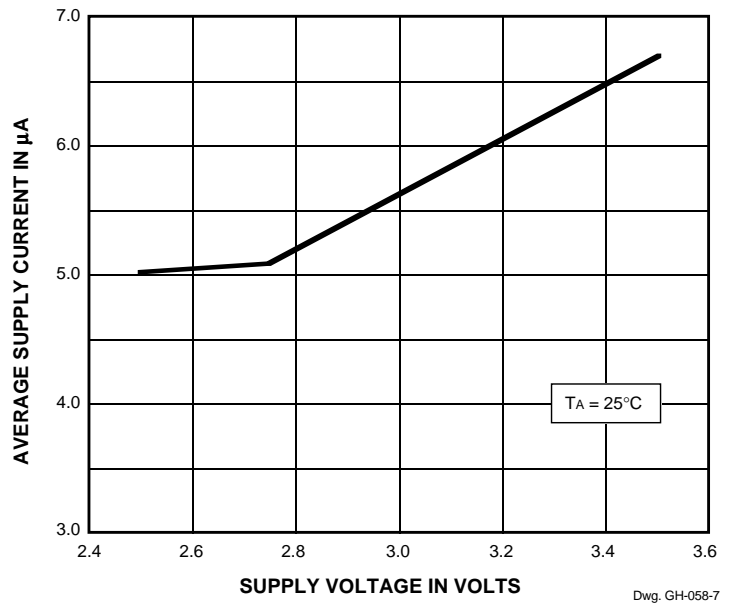
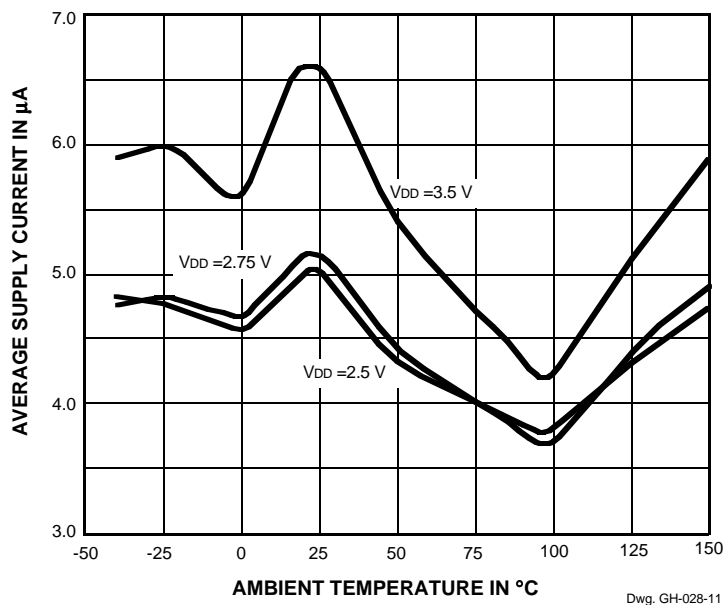

A3212 MICROPOWER, ULTRA-SENSITIVE HALL-EFFECT SWITCH

FUNCTIONAL DESCRIPTION

Low Average Power. Internal timing circuitry activates the sensor for 45 μ s and deactivates it for the remainder of the period (45 ms). A short "awake" time allows for stabilization prior to the sensor sampling and data latching on the falling edge of the timing pulse. The output during the "sleep" time is latched in the last sampled state. The supply current is not affected by the output state.

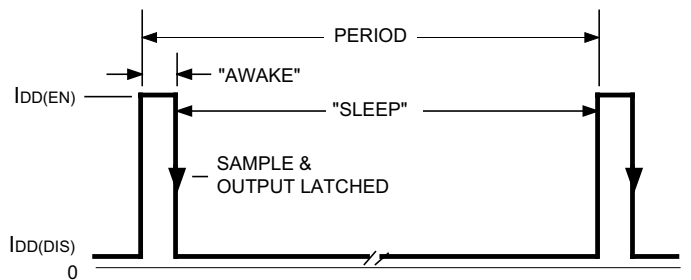

Dwg. WH-017-2

Chopper-Stabilized Technique. The Hall element can be considered as a resistor array similar to a Wheatstone bridge. A large portion of the offset is a result of the mismatching of these resistors. These devices use a proprietary dynamic offset cancellation technique, with an internal high-frequency clock to reduce the residual offset voltage of the Hall element that is normally caused by device overmolding, temperature dependencies, and thermal stress. The chopper-stabilizing technique cancels the mismatching of the resistor circuit by changing the direction of the current flowing through the Hall plate using CMOS switches and Hall voltage measurement taps, while maintaining the Hall-voltage signal that is induced by the external magnetic flux. The signal is then captured by a sample-and-hold circuit and further processed using low-offset bipolar circuitry. This technique produces devices that have an extremely stable quiescent Hall output voltage, are immune to thermal stress, and have precise recoverability after temperature cycling. A relatively high sampling frequency is used for faster signal processing capability can be processed.

More detailed descriptions of the circuit operation can be found in: Technical Paper STP 97-10, *Monolithic Magnetic Hall Sensor Using Dynamic Quadrature Offset Cancellation* and Technical Paper STP 99-1, *Chopper-Stabilized Amplifiers With A Track-and-Hold Signal Demodulator*.

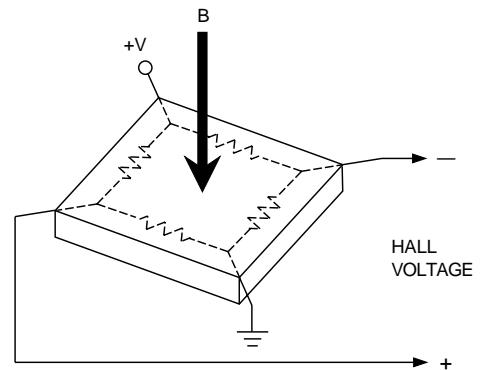

Dwg. AH-011-2

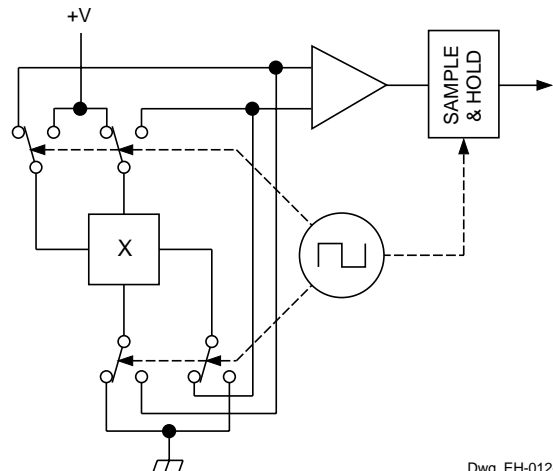

Dwg. EH-012-1

3212 MICROPOWER, ULTRA-SENSITIVE HALL-EFFECT SWITCH

FUNCTIONAL DESCRIPTION (cont'd)

Operation. The output of this device switches low (turns on) when a magnetic field perpendicular to the Hall sensor exceeds the operate point B_{OPS} (or is less than B_{OPN}). After turn-on, the output is capable of sinking up to 1 mA and the output voltage is $V_{OUT(ON)}$. When the magnetic field is reduced below the release point B_{RPS} (or increased above B_{RPN}), the device output switches high (turns off). The difference in the magnetic operate and release points is the hysteresis (B_{hys}) of the device. This built-in hysteresis allows clean switching of the output even in the presence of external mechanical vibration and electrical noise.

As used here, negative flux densities are defined as less than zero (algebraic convention), i.e., -50 G is less than +10 G.

Applications. Allegro's pole-independent sensing technique allows for operation with either a north pole or south pole magnet orientation, enhancing the manufacturability of the device. The state-of-the-art technology provides the same output polarity for either pole face.

It is strongly recommended that an external bypass capacitor be connected (in close proximity to the Hall sensor) between the supply and ground of the device to reduce both external noise and noise generated by the chopper-stabilization technique. This is especially true due to the relatively high impedance of battery supplies.

The simplest form of magnet that will operate these devices is a bar magnet with either pole near the branded surface of the device. Many other methods of operation are possible. Extensive applications information for Hall-effect sensors is available in:

- *Hall-Effect IC Applications Guide*, Application Note 27701;
- *Hall-Effect Devices: Soldering, Gluing, Potting, Encapsulating, and Lead Forming*, Application Note 27703.1;
- *Soldering of Through-Hole Hall-Sensor Devices*, Application Note 27703; and
- *Soldering of Surface-Mount Hall-Sensor Devices*, Application Note 27703.2.

All are provided at

www.allegromicro.com

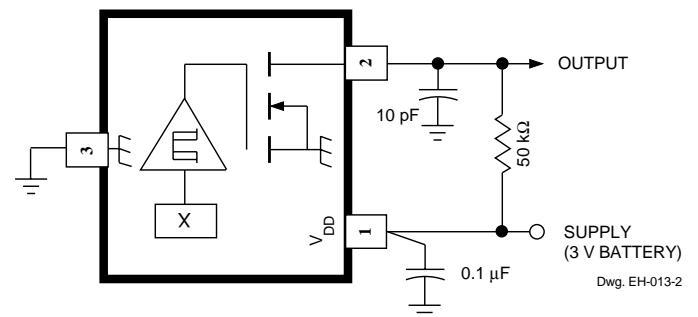
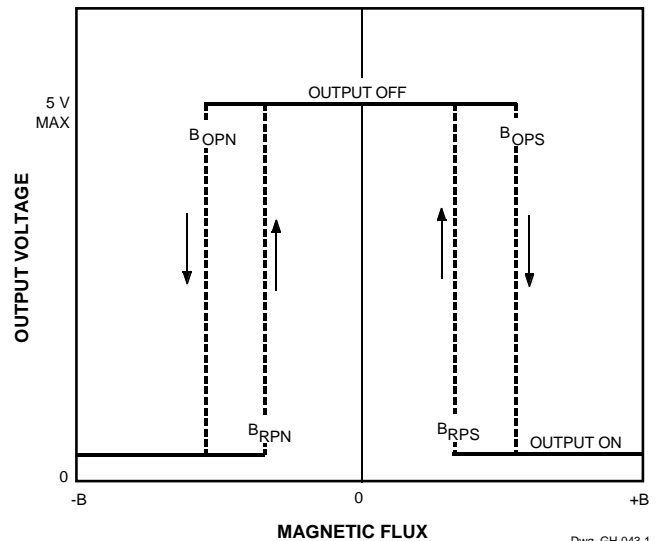

A3212
MICROPOWER,
ULTRA-SENSITIVE
HALL-EFFECT SWITCH

SENSOR LOCATIONS

Package Designator 'EH'

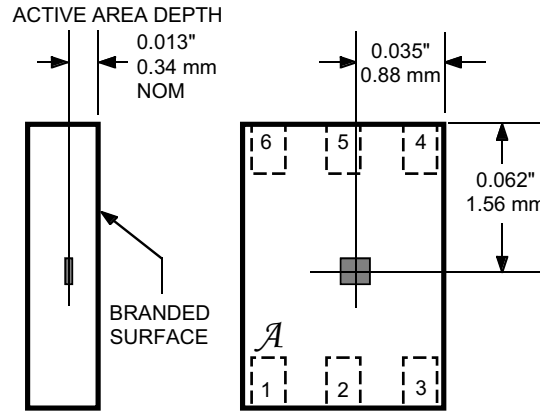

Dwg. MH-030

Package Designator 'LH'

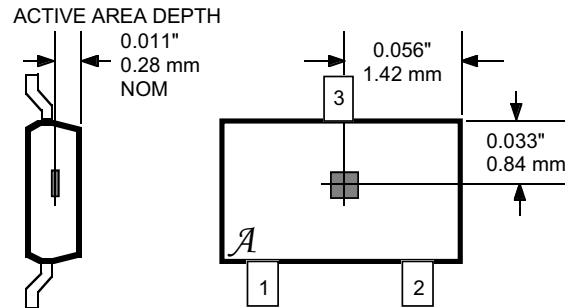

Dwg. MH-025-2

Package Designator 'UA'

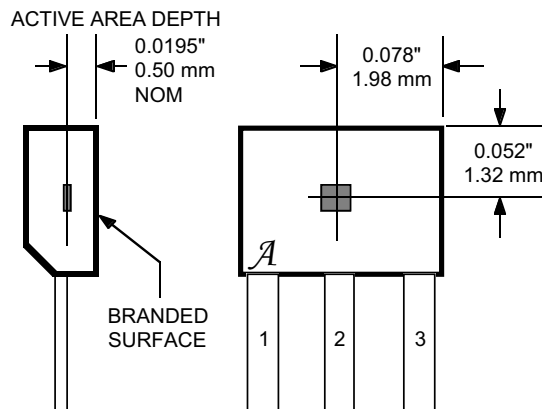

Dwg. MH-011-13

3212 MICROPOWER, ULTRA-SENSITIVE HALL-EFFECT SWITCH

PACKAGE DESIGNATOR 'EH'

(Reference MO-229C WCED-1)

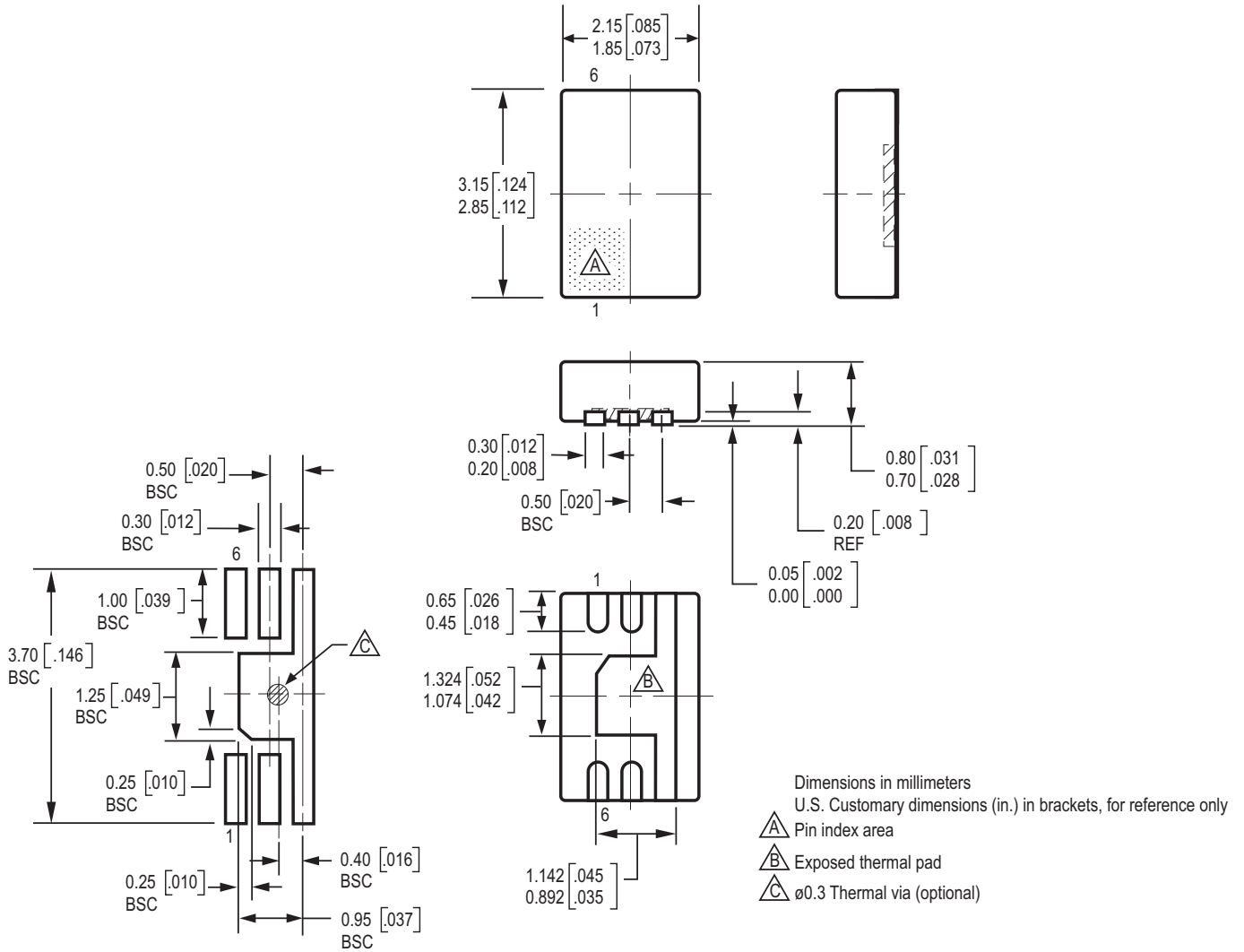

3212 MICROPOWER, ULTRA-SENSITIVE HALL-EFFECT SWITCH

PACKAGE DESIGNATOR 'LH' (SOT23W, fits SC-59A solder-pad layout)

Dimensions in Inches
(for reference only)

Dimensions in Millimeters
(controlling dimensions)

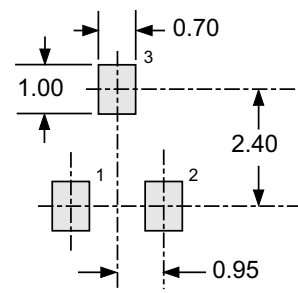
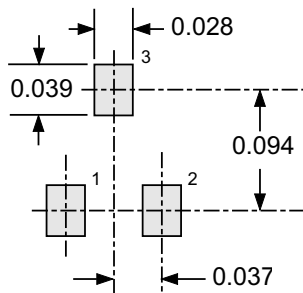
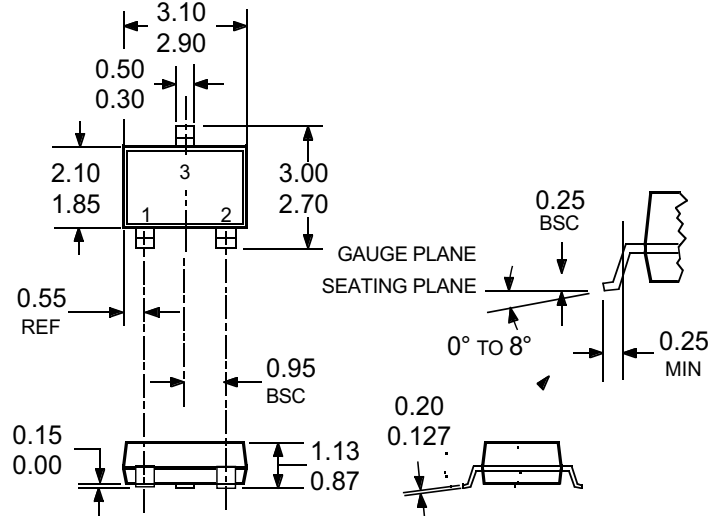
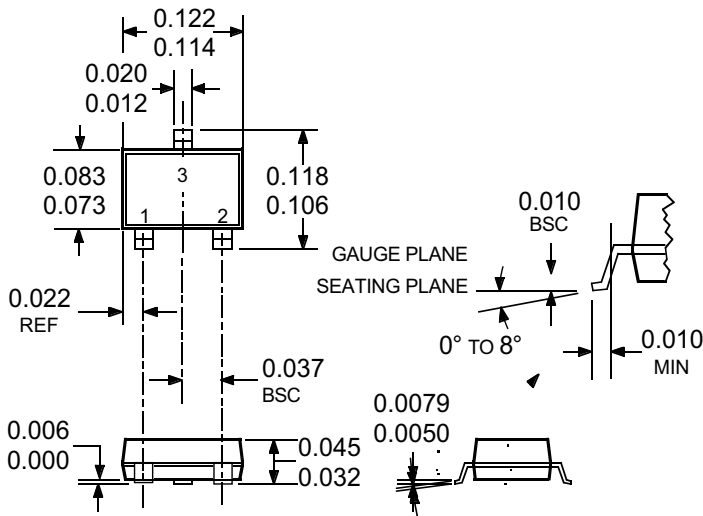

- NOTES: 1. Tolerances on package height and width represent allowable mold offsets. Dimensions given are measured at the widest point (parting line).
 2. Exact body and lead configuration at vendor's option within limits shown.
 3. Height does not include mold gate flash.
 4. Where no tolerance is specified, dimension is nominal.

A3212 MICROPOWER, ULTRA-SENSITIVE HALL-EFFECT SWITCH

PACKAGE DESIGNATOR 'UA'

Dimensions in Inches
(controlling dimensions)

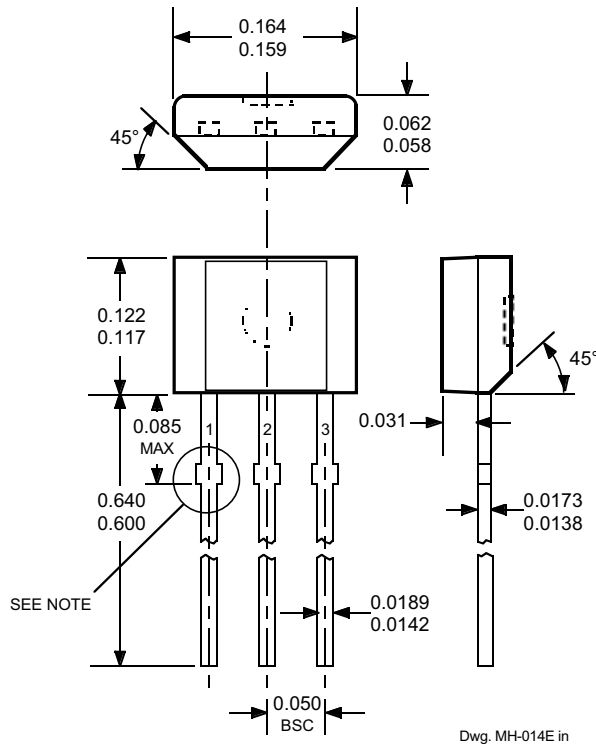

Dimensions in Millimeters
(for reference only)

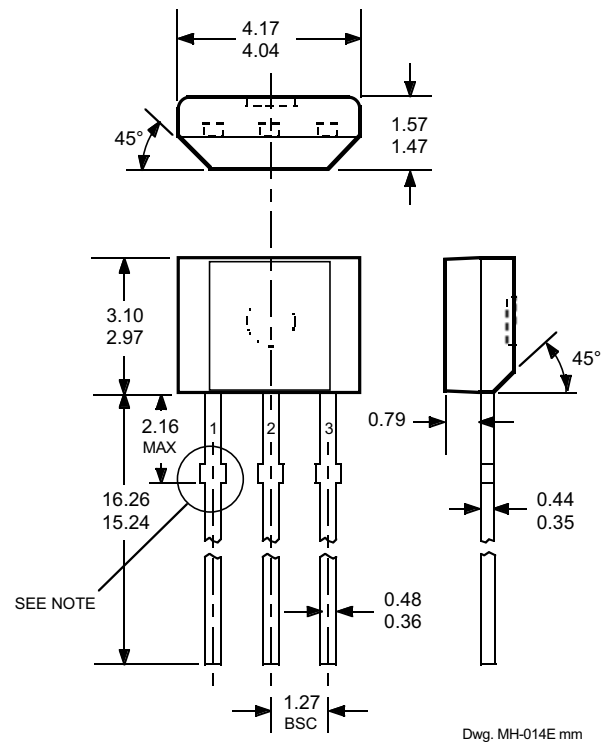

- NOTES: 1. Tolerances on package height and width represent allowable mold offsets. Dimensions given are measured at the widest point (parting line).
2. Exact body and lead configuration at vendor's option within limits shown.
3. Height does not include mold gate flash.
4. Recommended minimum PWB hole diameter to clear transition area is 0.035" (0.89 mm).
5. Where no tolerance is specified, dimension is nominal.

3212
MICROPOWER,
ULTRA-SENSITIVE
HALL-EFFECT SWITCH

The products described herein are manufactured under one or more of the following U.S. patents: 5,045,920; 5,264,783; 5,442,283; 5,389,889; 5,581,179; 5,517,112; 5,619,137; 5,621,319; 5,650,719; 5,686,894; 5,694,038; 5,729,130; 5,917,320; and other patents pending.

Allegro MicroSystems, Inc. reserves the right to make, from time to time, such departures from the detail specifications as may be required to permit improvements in the performance, reliability, or manufacturability of its products. Before placing an order, the user is cautioned to verify that the information being relied upon is current.

Allegro products are not authorized for use as critical components in life-support appliances, devices, or systems without express written approval.

The information included herein is believed to be accurate and reliable. However, Allegro MicroSystems, Inc. assumes no responsibility for its use; nor for any infringements of patents or other rights of third parties that may result from its use.