

Photodiode I-V Conversion Amplifier

Description

CXA1103AM is a trans-impedance type, wide band low noise amplifier for photo detector. Combined with a pin photodiode it composes a high performance optical receiver.

Features

- Wide band (DC to 40MHz -3dB)
- Low noise ($-147\text{dBV}/\sqrt{\text{Hz}}$ $f=10\text{MHz}$)
- Photodiode capacitance value, usage possible within 2 to 50pF range.
- Voltage regulator allows for wide range supply voltage (4.75 to 9.5V).

Applications

- Optical link reception amplifier.
- Index signal detector for index CRT.
- Fields that require both wide band and low noise characteristics.

Package Outline

Unit : mm

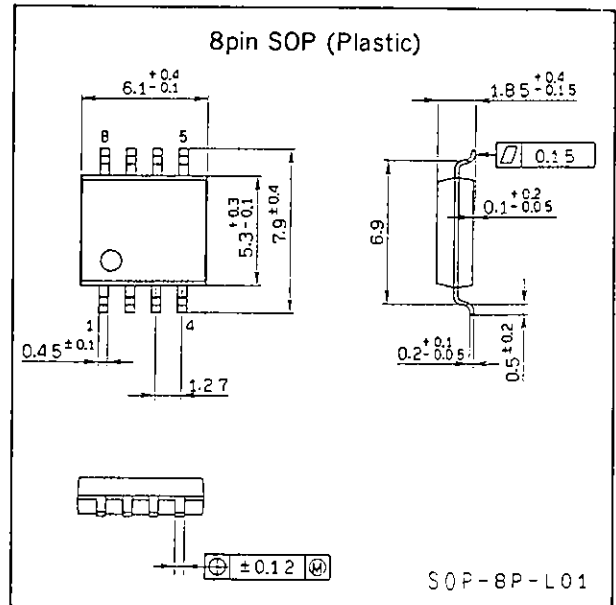

Absolute Maximum Ratings (Ta=25°C)

• Supply voltage	V _{cc}	10	V
• Operating temperature	T _{opr}	-20 to +75	°C
• Storage temperature	T _{stg}	-55 to +150	°C
• Allowable power dissipation	P _D	416	mW

Recommended Operating Conditions

• Supply voltage	V _{cc}	4.75 to 9.5	V
------------------	-----------------	-------------	---

Block Diagram and Pin Configuration (Top View)

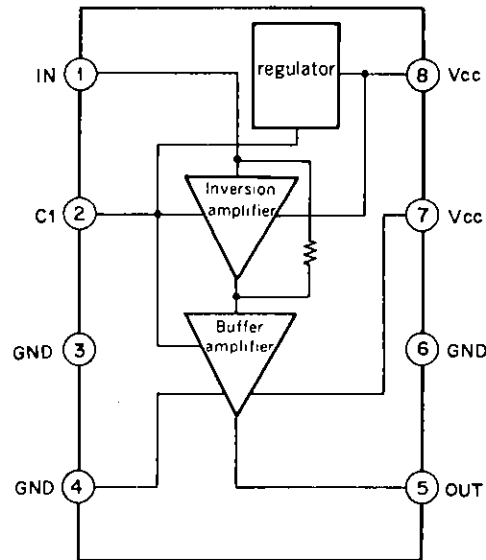

Pin Description and Equivalent Circuit

No.	Symbol	Voltage	Equivalent circuit	Description
1	IN	7.0V		Input pin
2	C1	6.3V		Input transistor emitter pin. Normally connected with GND by capacitor.
3	GND			GND
4	GND			GND
5	OUT	6.9V		Output pin
6	GND			GND
7	Vcc	* 9.0V		Supply pin
8	Vcc	* 9.0V		Supply pin

* Externally applied voltage

Electrical Characteristics

Ta=25°C, Vcc=9V

Item	Symbol	Conditions	Min.	Typ.	Max.	Unit
Supply current	I _{CC}		4.5	7.4	10.0	mA
Input voltage (DC)	V _I	SW1, SW2 ON *1	6.0	7.0	8.0	V
Output voltage (DC)	V _O	SW2 ON	6.4	6.9	7.4	V
Output impedance	Z _O	DC	45	75	100	Ω
Output noise voltage	V _{NO}	f=10MHz SW5 ON		-147.1	-144.1	dBV/ Hz
Trans-impedance	Z ₂₁	f=10MHz SW3 ON, SW5 ON	14.0	18.0		kΩ
Input noise current	I _{NI}	f=10MHz SW5 ON *2		2.4	3.4	pA/ Hz
Frequency band width	BW	SW4 ON	20	40		MHz

Note) *1. V_I=V_{C1}+0.7V

Because of oscillations, it is impossible to test the input pin voltage (V_I) directly.

Then, pin 2 voltage (V_{C1}) is tested and the value obtained through the above formula is taken as V_I.

*2. [Input noise current (I_{NI})] = [Output noise voltage (V_{NO})] / [Trans-impedance (Z₂₁)]

Electrical Characteristics Test Circuit

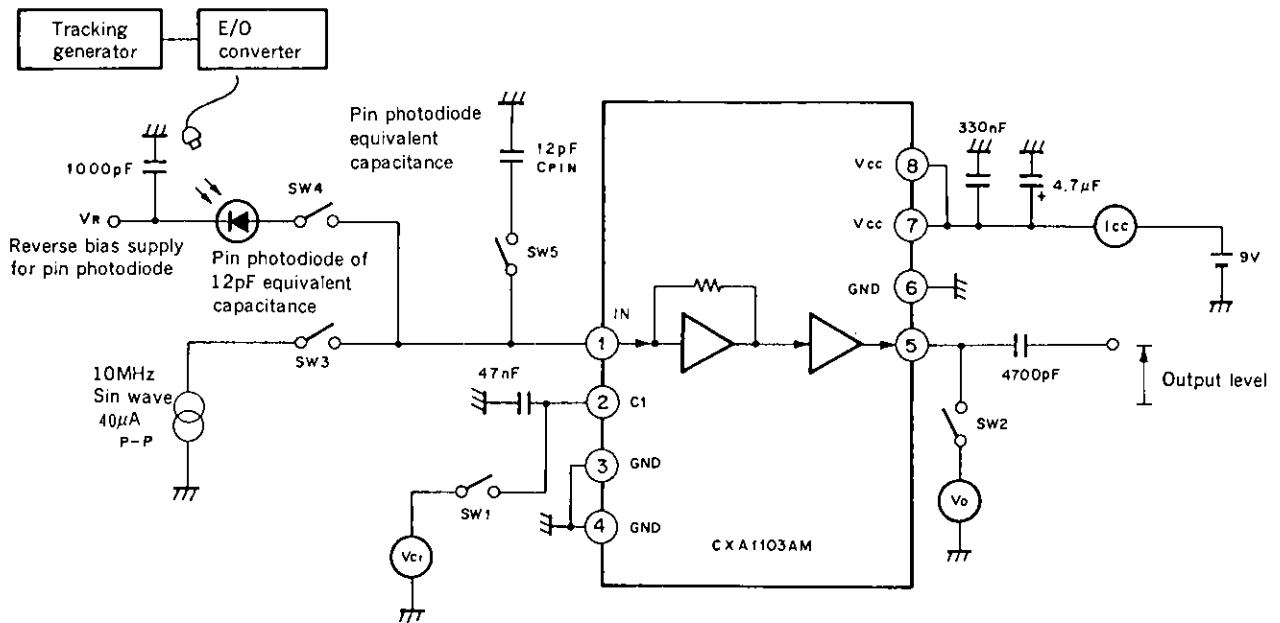

Fig. 1

Operation

- This IC is composed of a current to voltage conversion amplifier, an output buffer amplifier and a voltage regulator.
- Voltage regulator performs a stable operation through a wide supply voltage, $V_{CC}=4.75$ to $9.5V$.
- Current signal generated at the pin photodiode enters the input pin (pin 1) to be converted into voltage signal through the current to voltage conversion amplifier. (Input signal current \times feedback resistance). Then this voltage signal is converted into low impedance output signal by means of the output buffer amplifier.
- The frequency characteristics of output signal can be adjusted by varying the equivalent capacitance value of the photodiode. (See Fig. 6)
- To obtain a high S/N at the high frequency region, use a pin photodiode with an equivalent capacitance value as small as possible.
- The emitter of input transistor of the current to voltage conversion amplifier (pin 2) is to be grounded through the capacitor (C_1).

Application Circuit

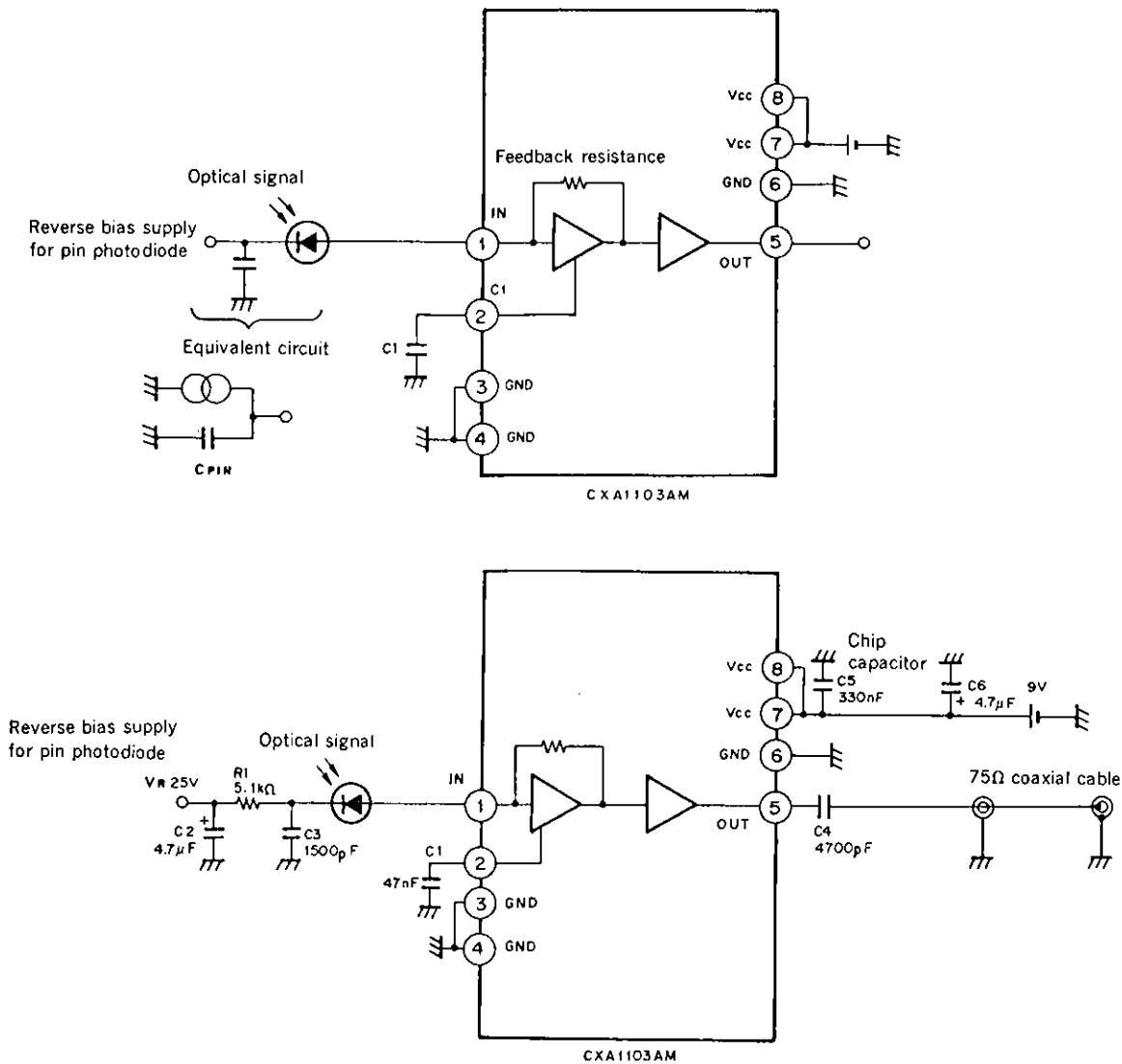

Fig. 2

Print Circuit Board Pattern (IC mount surface)

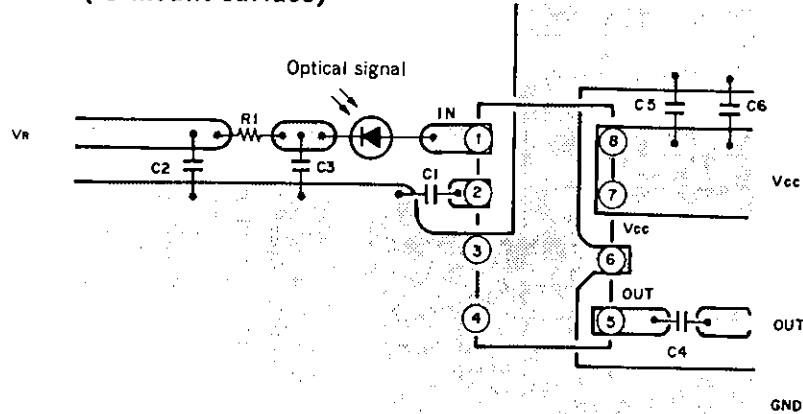

Fig. 3

Handling (See Application Circuit Fig.2 and Print Circuit Board Pattern Fig. 3)

- As seen in Fig. 3, mount the bypass capacitor as short as possible between pins 7,8 (Vcc) and pins 3,4,6 (GND).
A capacitor with long lead will cause parasitic oscillations and will make frequency characteristics worse. Keep this length at 2mm or less.
Chip capacitor is most suitable for C5 as it has no lead.
- Keep the shortest distance between the photo detector and this IC's input pin (pin 1).
In case this distance is too long, stray capacitance will increase and affect both the frequency characteristics and S/N.

Note) Unless otherwise specified ($V_{CC}=9V$ $C_{PIN}=12pF$ $T_a=25^{\circ}C$)

C pin: Pin photodiode equivalent capacitance

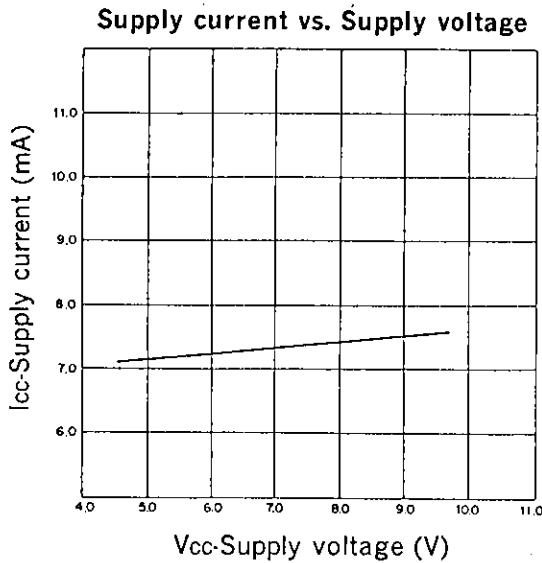

Fig. 4

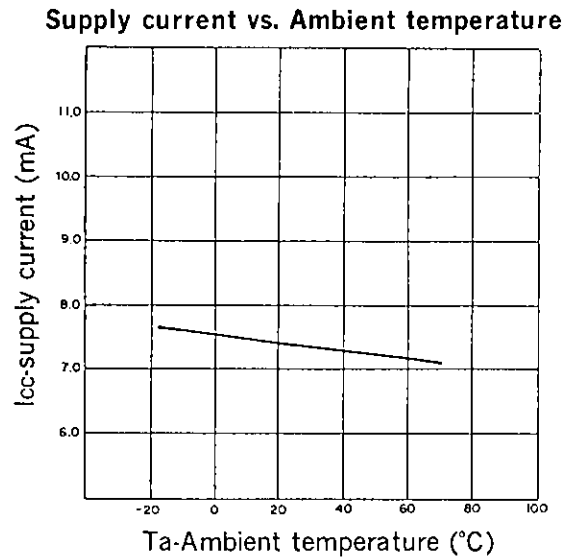

Fig. 5

Frequency characteristics

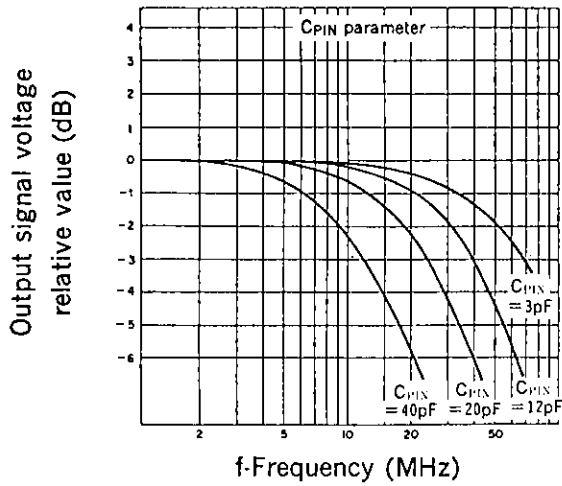

Fig. 6

Output noise voltage vs. Frequency

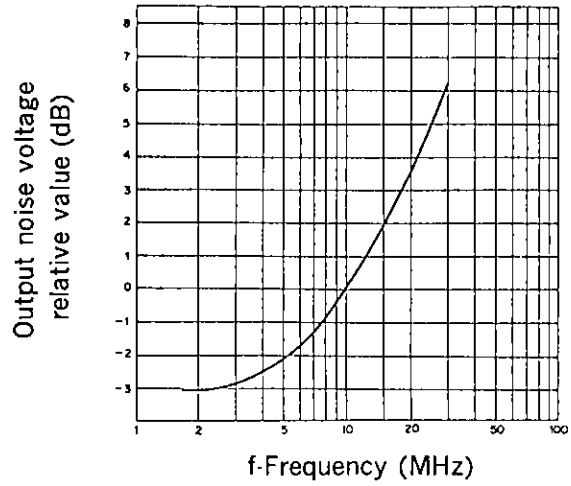

Fig. 7

Output noise voltage vs. Pin photodiode equivalent capacitance 1

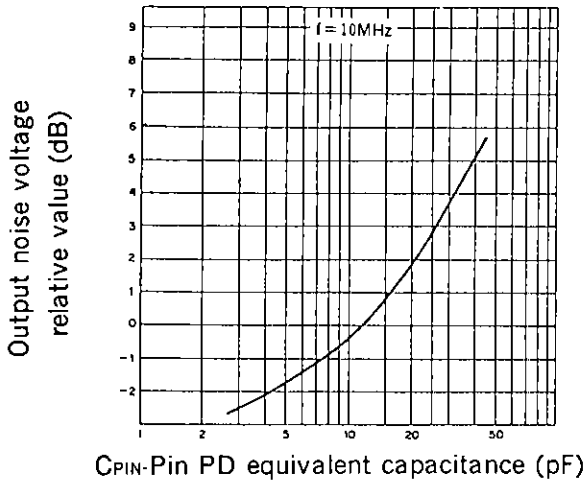

Fig. 8

Output noise voltage vs. Pin photodiode equivalent capacitance 2

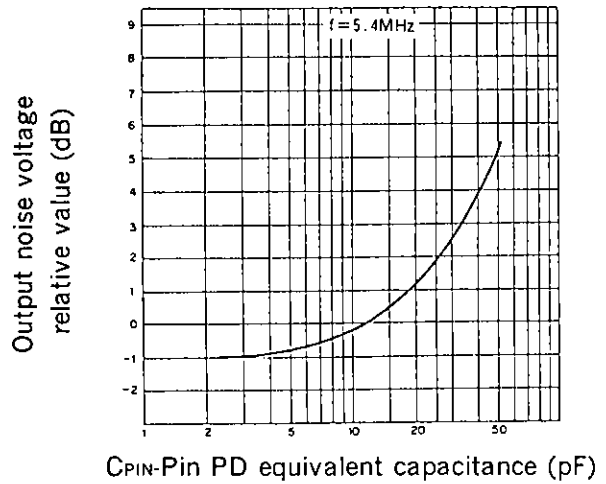

Fig. 9

Output noise voltage vs. Ambient temperature

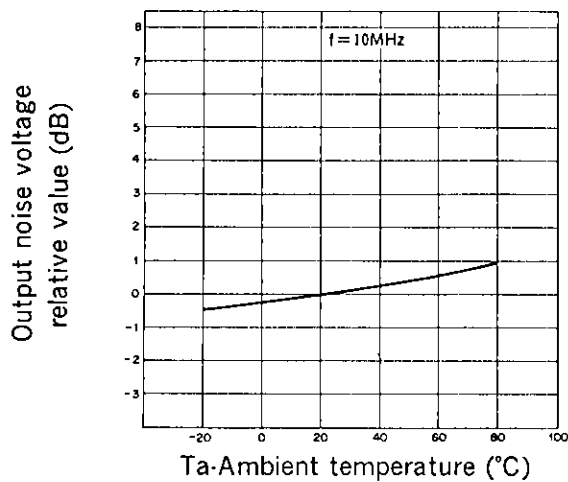

Fig. 10