

HA13456A/AMP

Three-Phase Brushless DC Motor Driver

Description

The HA13456/AMP three-phase brushless DC motor driver can provide an output current of 1.0 A per phase. It is intended for use as a floppy disk drive spindle motor driver.

Features

- Single-chip motor driver
- Digital control eliminates need for calibration
- Low current consumption

Functions

- 1.0-A three-phase output circuit
- Hall amplifier matrix
- Control amplifier (current control)
- FG amplifier, zero-cross detector
- Oscillator circuit
- High-speed discriminator
- 300 or 360 rpm
- Integrating amplifier
- Current limiter
- Overtemperature shutdown (OTSD)
- Chip enable

Product Line-up

Name	Package
HA13456A	DP-24TS
HA13456AMP	MP-28T

Pin Arrangement

HA13456A

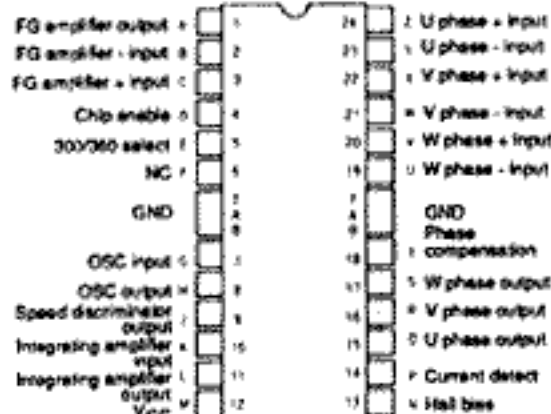

(Top View)

HA13456AMP

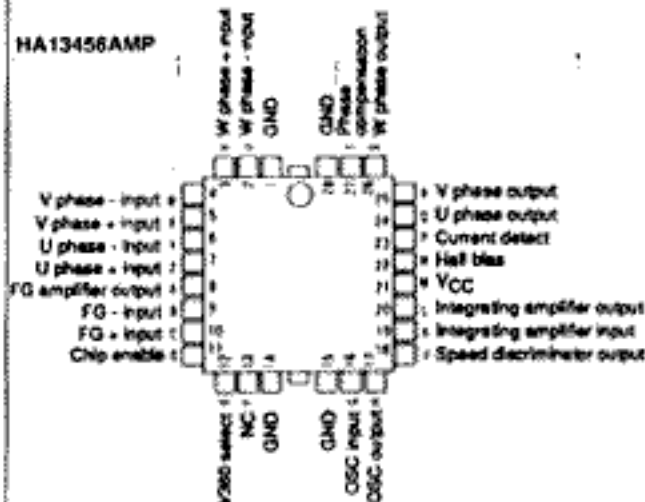

(Top View)

Block Diagram

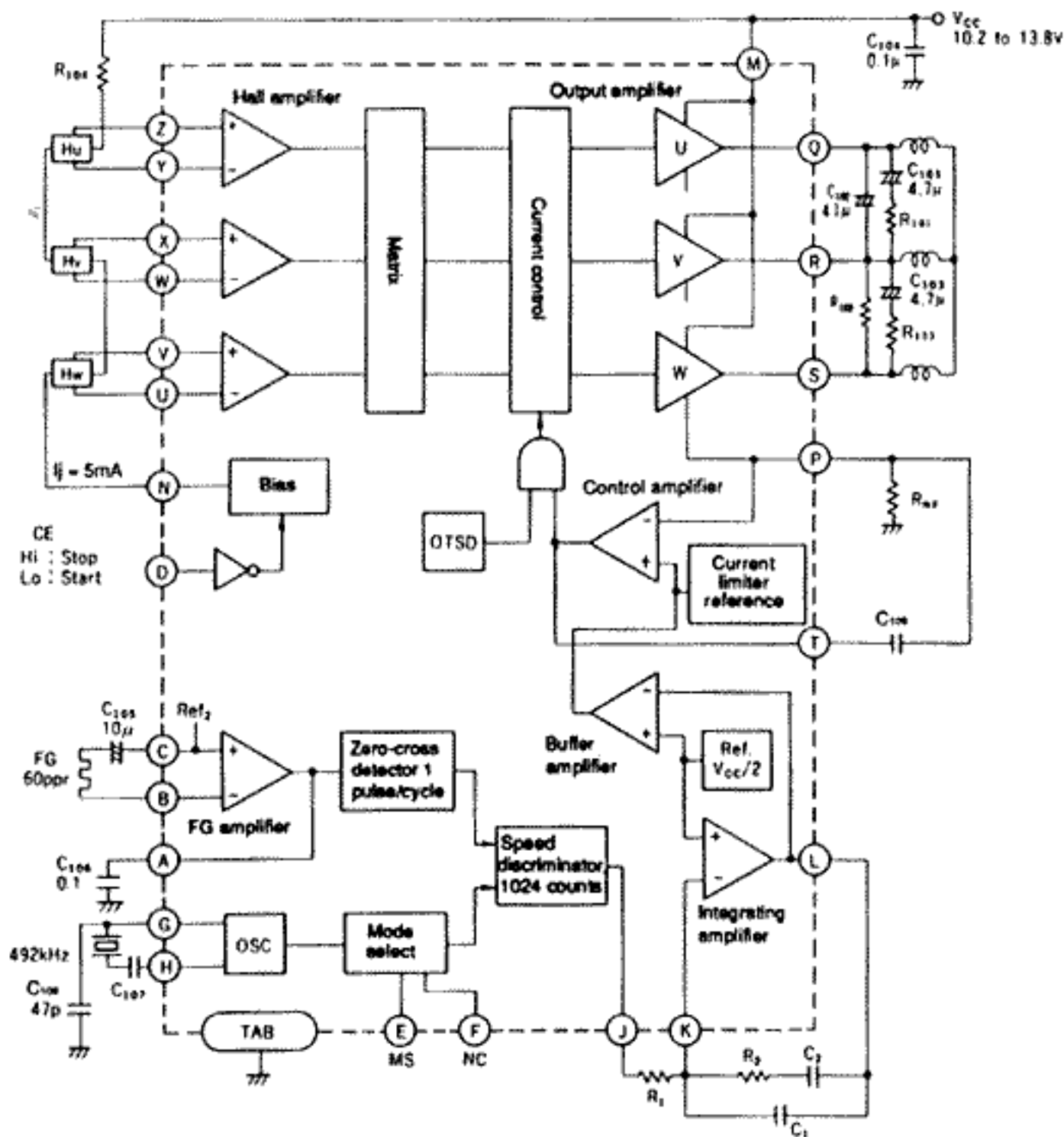

HA13456A/AMP

Truth Table

Chip Enable CE	Hall amplifier input						Output		
	U+	U-	V+	V-	W+	W-	U	V	W
L	H	L	L	H	H	L	H	L	Open
	H	L	L	H	L	H	H	Open	L
	H	L	H	L	L	H	Open	H	L
	L	H	H	L	L	H	L	H	Open
	L	H	H	L	H	L	L	Open	H
	L	H	L	H	H	L	Open	L	H
H	X	X	X	X	X	X	Open	Open	Open

Absolute Maximum Ratings (Ta = 25°C)

Item	Symbol	Rating	Unit	Notes
Power supply voltage	V _{CC}	+15	V	1
Peak output current	I _{op}	1.0	A	2
Normal output current	I _o	0.7	A	
Input voltage	V _{in}	-0.5 to V _{CC}	V	3
Power dissipation	P _f	2	W	4
Junction temperature	T _j	150	°C	5
Storage temperature	T _{stg}	-55 to +125	°C	

Notes:

1. The operating voltage range (V_{CC}) is 10.2 to 13.8 V.
2. t ≤ 0.5 seconds
3. Applies to chip enable CE and mode select MS pins.
4. For T_c=100°C. Thermal resistance is as follows.
θ_{j-c} ≤ 20°C/W
θ_{j-a} ≤ 60°C/W (when using glass epoxy baseplate)
5. Operating junction temperature (T_{jopr}) range is 0 to 125°C.

Electrical Characteristics ($T_a = 25^\circ\text{C}$, $V_{CC} = 12\text{V}$)

Item	Symbol	Min	Typ	Max	Unit	Test Conditions	Pins		Notes	
							DP-24TS	MP-28T		
Quiescent current	I_{Q1}	—	0.45	1.0	mA	$CE = 2\text{V}$	12	21	1	
	I_{Q2}	—	15	23	mA	$CE = 0.8\text{V}$, $R_L = \text{OPEN}$				
Input low voltage	V_{IL}	—	—	0.8	V		4, 5	11, 12		
Input high voltage	V_{IH}	2.0	—	V_{CC}	V					
Input low current	I_{IL}	—	—	± 20	μA	$V_{IL} = 0\text{V}$				
Input high current	I_{IH}	50	—	200	μA	$V_{IH} = 2\text{V}$	4	11		
		—	—	± 10	μA		5	12		
Hall amplifier	Input current	I_{HB}	—	—	± 10	μA	$V_H = 2\text{V}$	19–24	2–7	
	Input common mode voltage range	V_H	1.5	—	V_{CC}	V				
				—1.0						
	Differential input voltage range	U_H	75	—	—	mVpp				
Hall bias	Output voltage	V_{HB}	1.2	1.6	2.0	V	$CE = 0.8\text{V}$, $I_D = 5\text{mA}$	13	22	
	Leakage current	$I_{H\text{ off}}$	—	—	± 10	μA	$CE = 2\text{V}$, $V_{CE} = 15\text{V}$			
Output amplifier	Leakage current	I_{CER}	—	—	± 1	mA	$CE = 2\text{V}$, $V_{CE} = 15\text{V}$	15,	24,	
	Saturation voltage	V_{sat}	—	1.5	2.2	V	$I_D = 0.7\text{A}$	16,	25,	2
—			1.2	1.6	V	$I_D = 0.35\text{A}$	17,	26		
Current limiter reference voltage	V_{ref1}	370	410	450	V		14	23		
Control amplifier	Voltage gain	G_{CTL}	-2	0	+2	V		14	23	
	Phase deviation	ΔG_{CTL}	—	—	± 1.0	dB				
Integrating amplifier	Reference voltage	V_{ref2}	—	6.3	—	dB		10	19	
	Input current	I_{B1}	—	—	± 50	nA				
	Output voltage amplitude	$A +$	—	0.7	—	V	$I_g = -0.5\text{mA}$	11	20	3
			—	-1.3	—	V	$I_g = 0.5\text{mA}$			
Gain bandwidth	BW_D	—	300	—	kHz	$G_V = 0\text{dB}$				
Speed discriminator	Output high voltage	V_{DOH}	V_{CC}	—	—	V	$I_{10} = 0.5\text{mA}$	9	18	
			-0.3							
	Output low voltage	V_{DOL}	—	—	0.3	V	$I_{10} = -0.5\text{mA}$			
	Output cutoff current	$I_{D\text{ off}}$	—	—	± 50	nA	$V = 2.5\text{V}$			
	Operating frequency	f_D	—	—	1000	kHz				
	Number of counts	N_D	—	1024	—	—				
OSC	Frequency range	f_{OSC}	—	—	1000	kHz		8	17	
	Frequency error	Δf_{OSC}	—	—	± 0.2	%	492 kHz			
FG amplifier	Voltage gain	G_{FG}	38	40	42	dB	$f = 300\text{Hz}$	1	8	
	Undistorted maximum output voltage	V_O	0.4	—	—	Vrms				
	Input voltage	V_I	2	—	—	mVpp		2, 3	9, 10	
OTSD	Operating temperature	T_{ad}	12.5	—	—	$^\circ\text{C}$				4

Notes.

1. Not including Hall bias current.
2. Sum of upper and lower saturation voltages.
3. Based on V_{ref2} .
4. For reference only; not tested before delivery.

HA13456A/AMP

External Components

Part No.	Reference Value	Purpose	Notes
	12 V, 5.25" FDD		
R ₁₀₁ , R ₁₀₂ , R ₁₀₃	4.7 Ω	Stability	
R ₁₀₄	1.8 kΩ	Hall amplifier bias	
R ₁	56 kΩ	Integration constant	
R ₂	56 kΩ	Integration constant	
R _{NF}	0.39 Ω	Current detect	1
C ₁₀₁ , C ₁₀₂ , C ₁₀₃	4.7 μF	Stability	2
C ₁₀₄	0.1 μF	Power supply bypass	3
C ₁₀₅	10 μF	AC connection to FG amplifier	
C ₁₀₆	0.1 μF	Bandwidth setting for FG amplifier	
C ₁₀₇	47 pF	AC connection to oscillator	
C ₁₀₈	47 pF	Stability	
C ₁₀₉	0.1 μF	Control amplifier phase compensation	
C ₁	0.04 μF	Integration constant	4
C ₂	0.47 μF	Integration constant	4
X _{tal}	492 kHz	Oscillator	5

Notes:

1. The current limiter operates according to the following equation.

$$I_{O \max} = \frac{V_{ref} 1}{R_{NF}}$$

2. Use non-polar capacitors.
3. Place as close as possible to the IC.
4. Use non-polar capacitor with low leakage current.
5. The relationship between the oscillator frequency $f_{osc}(\text{Hz})$ and the FG frequency $f_{FG}(\text{Hz})$ is as follows.
 - a. When MS = high:

$$f_{osc} = \frac{8 \times 1024 \times f_{FG}}{8}$$

- b. When MS = low:

$$8 \times 1024 \times f_{FG}$$