

2N5609

Silicon PNP Transistors



◆ Features

- With TO-66 package
- Designed for use as high-frequency drivers in audio amplifier

◆ Absolute Maximum Ratings Tc=25°C

SYMBOL	PARAMETER	RATING	UNIT
V _{CBO}	Collector to base voltage	80	V
V _{CEO}	Collector to emitter voltage	80	V
V _{EBO}	Emitter to base voltage	5.0	V
I _{CP}	Peak collector current		A
I _C	Collector current	5.0	A
P _C	Collector power dissipation	25	W
T _j	Junction temperature	150	°C
T _{stg}	Storage temperature	-55~150	°C

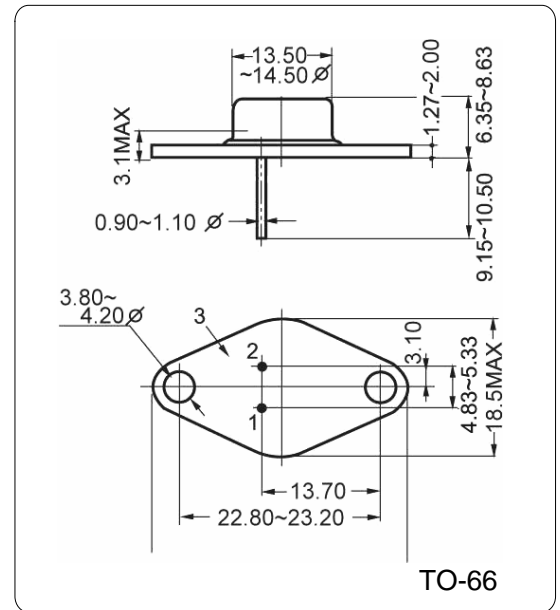

◆ Electrical Characteristics Tc=25°C

SYMBOL	PARAMETER	CONDITIONS	MIN	MAX	UNIT
I _{CBO}	Collector-base cut-off current	V _{CB} =80V; I _E =0		10	μ A
I _{EBO}	Emitter-base cut-off current	V _{EB} =5V, I _C =0		10	μ A
I _{CEO}	Collector-emitter cut-off current				
V _{CBO}	Collector-base breakdown voltage				
V _{(BR)CEO}	Collector-emitter breakdown voltage	I _C =10mA, I _B =0	80		V
V _{EBO}	Emitter-base breakdown voltage				
V _{CEsat-1}	Collector-emitter saturation voltages	I _C =1A; I _B =0.1A		0.5	V
V _{CEsat-2}	Collector-emitter saturation voltages				
V _{CEsat-3}	Collector-emitter saturation voltages				
V _{CEsat-4}	Collector-emitter saturation voltages				
h _{FE-1}	Forward current transfer ratio	I _C =2.5A, V _{CE} =5V	70	200	
h _{FE-2}	Forward current transfer ratio				
h _{FE-3}	Forward current transfer ratio				
h _{FE-4}	Forward current transfer ratio				
V _{BE(sat)1}	Base-emitter saturation voltages	I _C =1A, V _{CE} =2V		1.0	V
V _{BE(sat)2}	Base-emitter saturation voltages				
V _{BE(sat)3}	Base-emitter saturation voltages				
f _T	Transition frequency at f = 1MHz				
t _f	Fall time				
t _s	Turn-off storage time				